Table of Contents

Electronic Transmission Control Workbook

| Subject | Page |
|---|------|
| Objectives of the Module | 2 |
| Purpose of the System | 3 |
| Transmission Identification | 4 |
| Transmission Comonents | 8 |
| Transmission Features and Principles of Operation | 30 |
| Adaptive Feature | 43 |
| CAN Bus | 47 |
| TCM Coding and Programming | 52 |
| Transmission Fluid | 54 |
| Transmission Service | 56 |
| Transmission Diagnosis and Troubleshooting | 58 |
| Additional Information | 72 |
| Review Questions | 78 |

Model: All with BMW Automatic Transmission

Production: All

Objectives:

After completion of this module you will be able to:

- Gain practical knowledge of BMW EH Transmissions.
- Identify Electronic Transmission Control Components
- Test Electrical components within the transmission

Purpose of the System

Electronically controlled transmissions were introduced on BMW products in 1986 on 5 and 7 series vehicles. Currently EH (Electro-hydraulic) transmissions are offered on almost every production model (Except E46 M3 and E39 M5). EH transmissions offers the following benefits to the driver:

- Increased driving safety by reducing fatigue. All shifts are automatic as opposed to manual transmissions which require more driver interaction.
- Increased fuel economy through use of lock up torque converter.
- Increased fuel economy through optimized shift points.
- Improved shift comfort by use of “Overlap Shift” technology (ZF).
- More available features through the use of CAN bus technology.

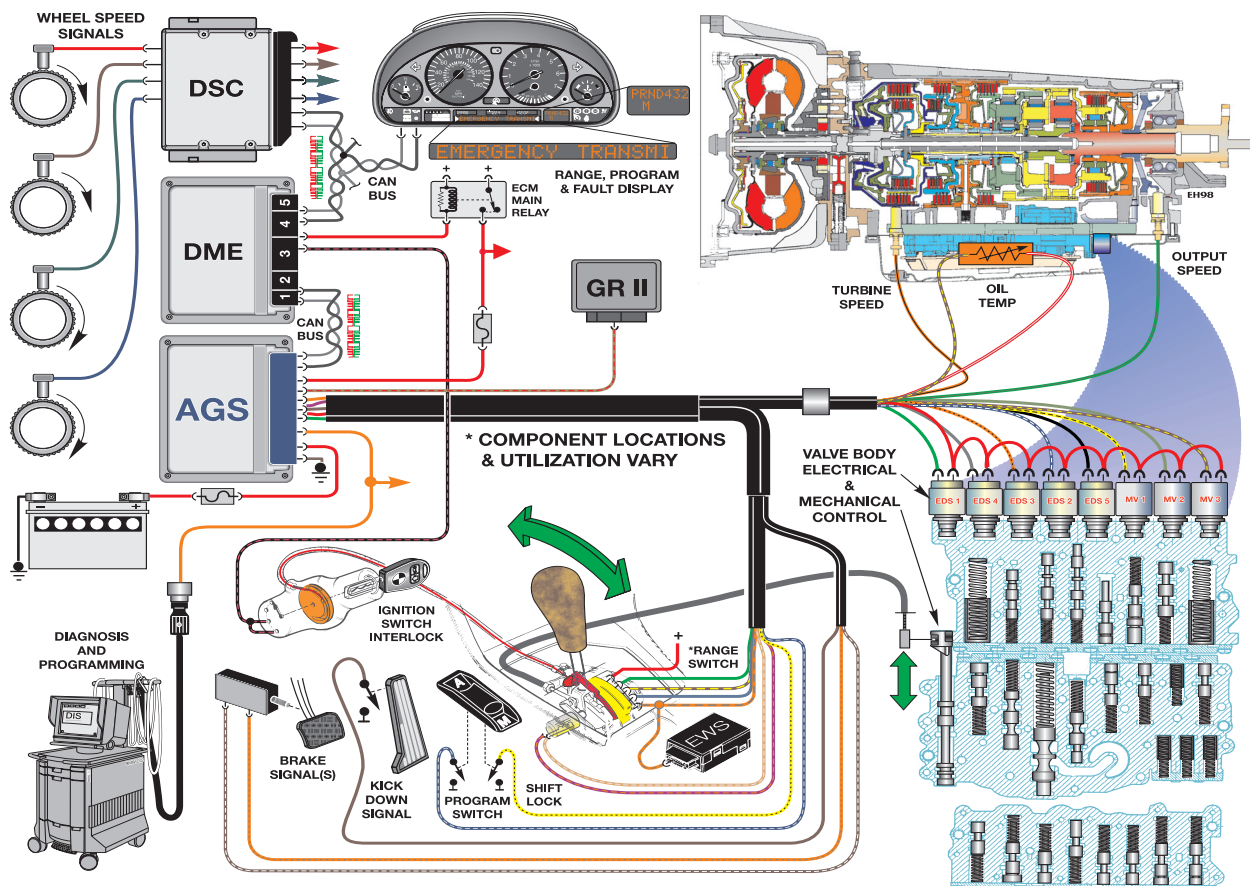

Transmission Identification

BMW automatic transmission are manufactured by two suppliers for the US market:

- **Zahnradfabrik Friedrichshafen:** Commonly referred to as ZF. ZF manufactures both manual as well as automatic transmissions.
- **GM Powertrain - Hydramatic:** Hydramatic is a manufacturing division of General Motors located in Strasbourg, France. Hydramatic supplies automatic transmissions to BMW for four and six-cylinder vehicles.

BMW has developed an internal numbering system for their transmissions for ordering parts, information research and identification. Also, each transmission manufacturer uses an internal identification system. Here is a breakdown of these identification codes:

BMW Identification Code Breakdown

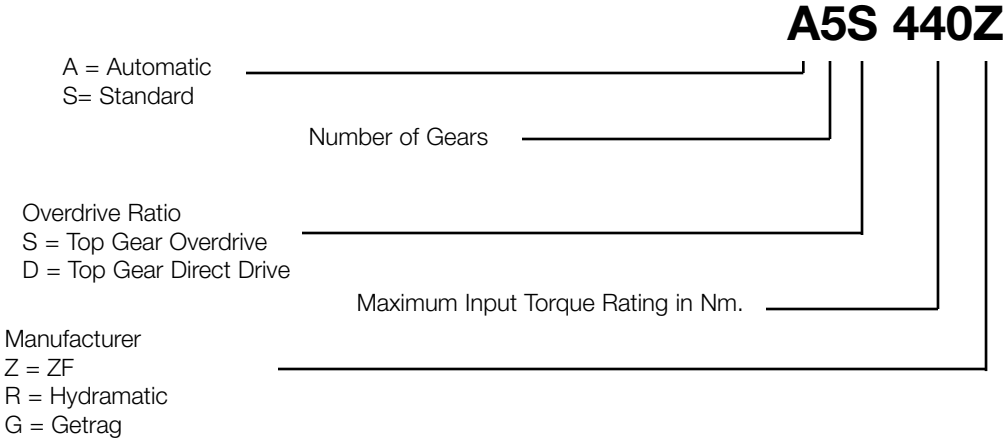

ZF Identification Code Breakdown

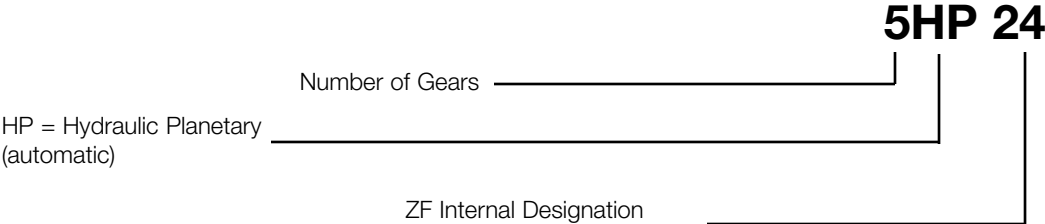

Hydramatic Transmissions have internal designations , however they are not used often. The internal code for the A4S310/270R is 4L30-E and the A5S360/390R is 5L40-E.

Transmission Identification

The following is a list of BMW Automatic Transmissions with visual references for identification. Also the diagrams below show the drain (1) and fill (2) plug locations. The transmission used in the current E65/E66 (GA6HP26Z) is not shown on this page, refer to additional text found in the pre-course material.

A5S310Z (5HP18)

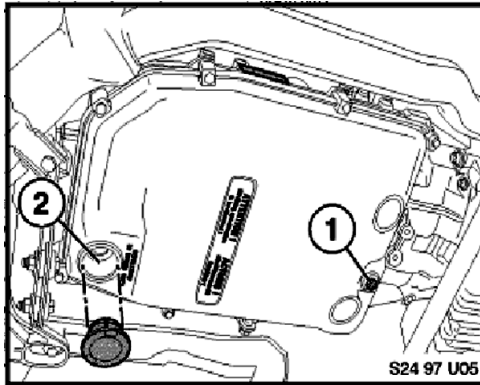

A5S325Z (5HP19)

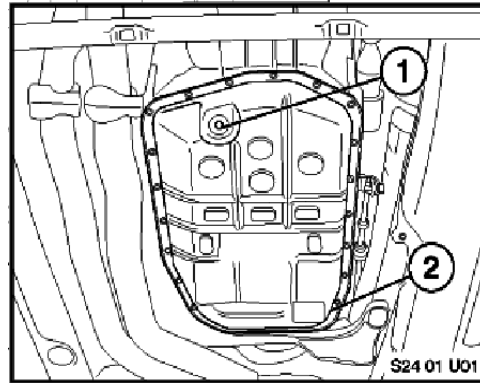

A5S440Z (5HP24)

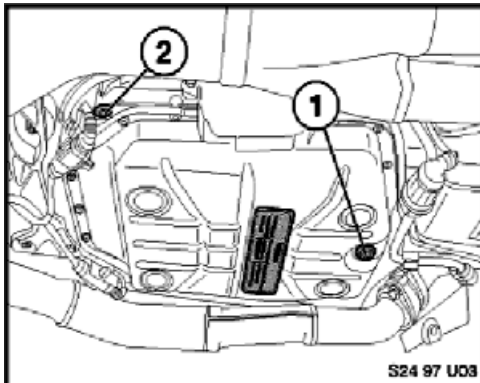

A5S560Z (5HP30)

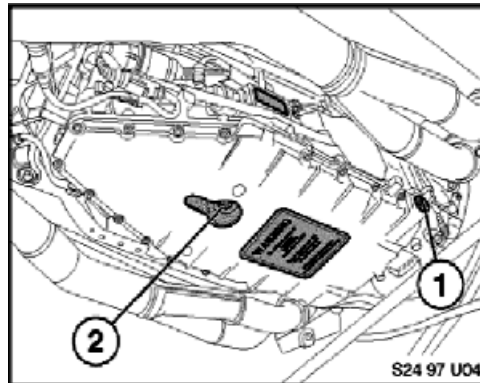

A4S270/310R (4L30-E)

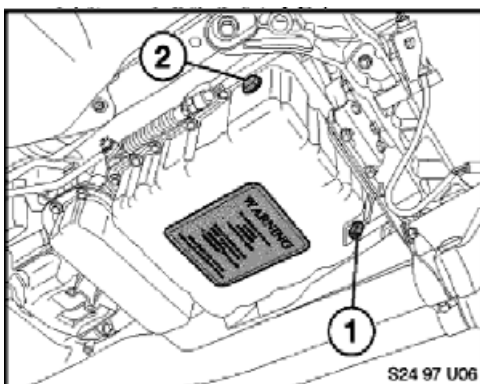

A5S360/390R (5L40-E)

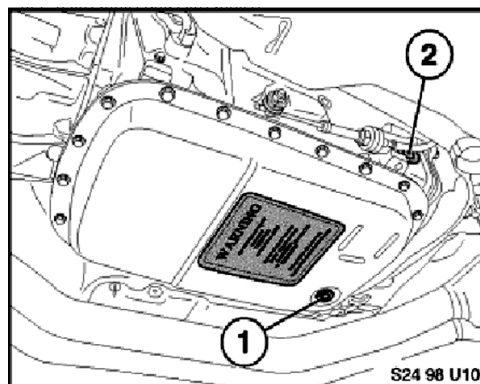

Transmission Identification

In order to identify BMW transmissions there are identification tags located externally on the transmission case. The tag contains information such as Manufacturer, Serial number, transmission type etc. This information is needed when ordering parts, referencing bulletins and calling for technical assistance.

- **ZF - Tag is Located on -**

1. Right hand side (passenger side) of transmission case. (5HP30 and 5HP18)
2. Left hand side (drivers side) of transmission case. (6HP26Z, 5HP24 and all 4HP)
3. Rear under output shaft. (5HP19)



ID Tag Location 5HP19

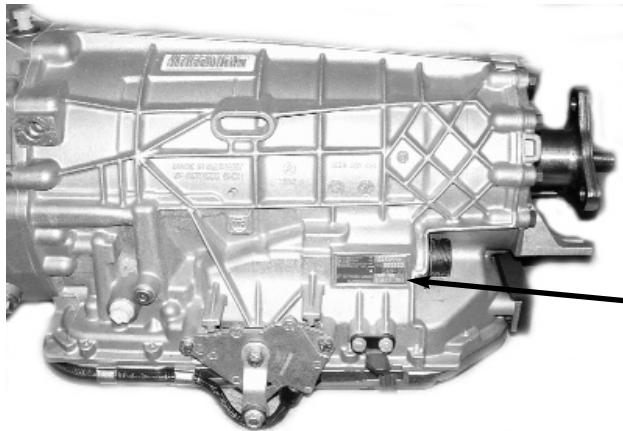

ID Tag Location 5HP24

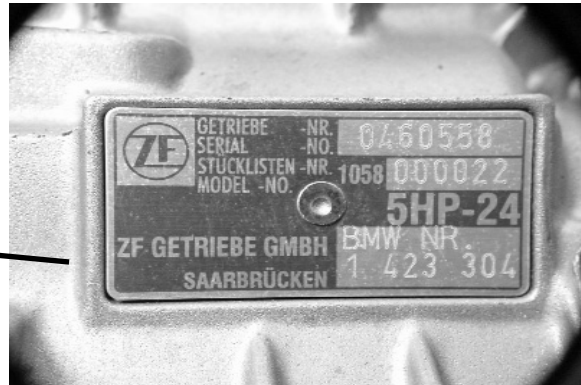

Typical ZF Tag

- **GM - Located on left hand side (drivers side) of transmission case.**



GM ID Tag (GM 5)

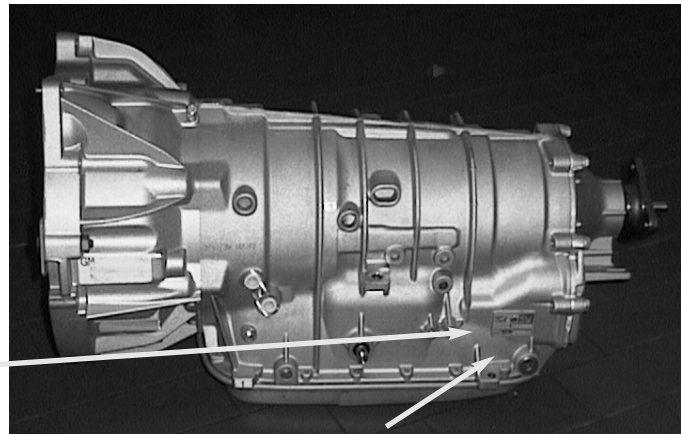

Hydramatic ID Tag Location (GM5)

Transmission Identification Worksheet

Task: Completely fill in the worksheet using instructor designated vehicle. Use ID Page and Transmission ID Tag.

Chassis #: _____ Prod Date: _____ Engine: _____

Transmission: _____ Control System: _____

TCM Type: (Pins) _____ TCM Part #: _____

Software #: _____ Programmed Control Unit #: _____

Identification Tag

Transmission Serial # _____

Location of ID Tag: _____

Describe the path used to locate the Identification page in the Diagnosis Program:

Notes:

Transmission Control Module

The TCM receives inputs, processes information and actuates the output elements to provide optimal shift points. The TCM is programmed for maximum shift comfort and fuel economy. The TCM on most BMW vehicles is located in the E-Box next to the ECM (DME). Always refer to the proper ETM for TCM location.

There are several types of TCM housings:

- 35 Pin TCM (TCU) - used on the 4HP transmissions
- 55 Pin TCM - used on the A4S310R (THM-R1)
- 88 Pin TCM - used on all others up to 98
- 134 Pin TCM - used on all BMW transmission from the 99 model year.
(Note- the 134 pin TCM was introduced on the 98 Models equipped with the A5S440Z).

The 134 Pin TCM is also referred to as SKE (Standard Shell Construction). The SKE housing uses 5 separate connectors. On transmission applications only three connectors 1, 3 and 4) are used. Connectors 2 and 5 are blank and are **NOT** used. The connectors are blue in color to avoid confusion with the ECM (DME) connectors which are black.

134 Pin control modules are supplied by Bosch for ZF transmissions and Siemens for Hydramatic transmissions. Bosch and Siemens control modules are NOT interchangeable.

134 Pin TCM
with SKE housing

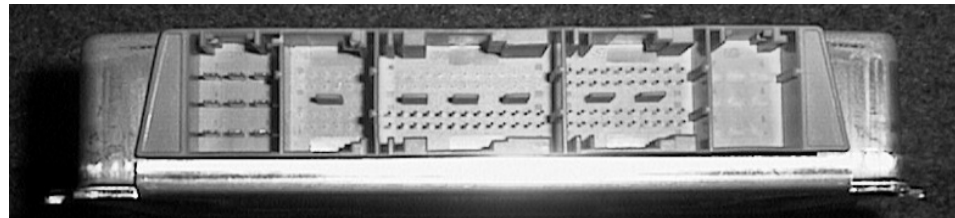

Connectors 1 2 3 4 5

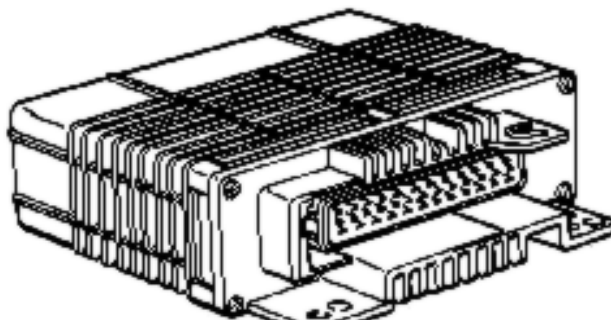

55 Pin TCM

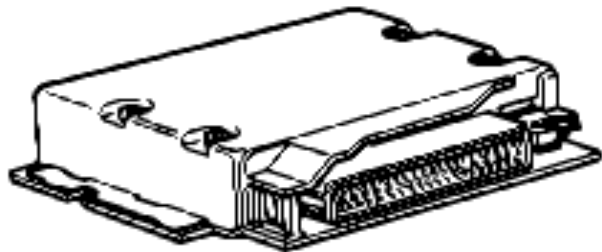

88 Pin TCM

Transmission Control Module Worksheet

Task: Completely fill in the worksheet using instructor designated vehicle.

Chassis #: _____ **Vehicle:** _____

Transmission: _____ **Control System:** _____

Where is the TCM located on this vehicle? _____

What type of TCM is used? (pins/manufacturer): _____

List the information found on the TCM label:

What special precautions (if any) should be observed when disconnecting the connector on this TCM?

List the special tool numbers of the Breakout Boxes used for this TCM:

Is this TCM flash programmable? _____

Notes:

Turbine Speed Sensor

The Turbine Speed Sensor is used to provide input (turbine) shaft speed information to the TCM (EGS). The input shaft speed signal is used in conjunction with the output shaft speed signal to determine gear range and slip time information for processing in the TCM. Not all BMW transmissions use a turbine speed sensor. Some TCM's use the TD (engine speed) signal to determine input shaft speed. All transmissions with the exception of the A5S325Z use an inductive type sensor which generates an AC analog signal. The A5S325Z currently uses a Hall Effect Turbine Speed Sensor which will send a digital square wave signal to the TCM.

4HP22/24 (EH), A4S310/270R: These transmissions do not use a Turbine Speed Sensor. The TD signal is used to determine input shaft speed. The TD signal is an output signal of the DME control unit.

A5S310Z, A5S325Z, A5S440Z, A5S560Z, A5S360/390R: These transmission use a turbine speed sensor. The TD signal is also used with the turbine speed signal to allow the TCM to monitor Torque Converter Clutch operation. The TCM can control torque converter clutch slippage and also monitor for faults.

Output Shaft Speed Sensor

The Output Shaft Speed Sensor is used to provide output shaft speed information to the TCM. The output shaft speed signal is used in conjunction with the turbine speed signal to provide the TCM with information on gear ranges and slip times.

All BMW electronic transmissions have an output shaft speed sensor. The output shaft speed sensor is an inductive type which will generate an AC analog signal to the TCM. The frequency and amplitude of the signal will increase as output shaft speed increases. The exact location of the output shaft speed sensor varies by transmission model.

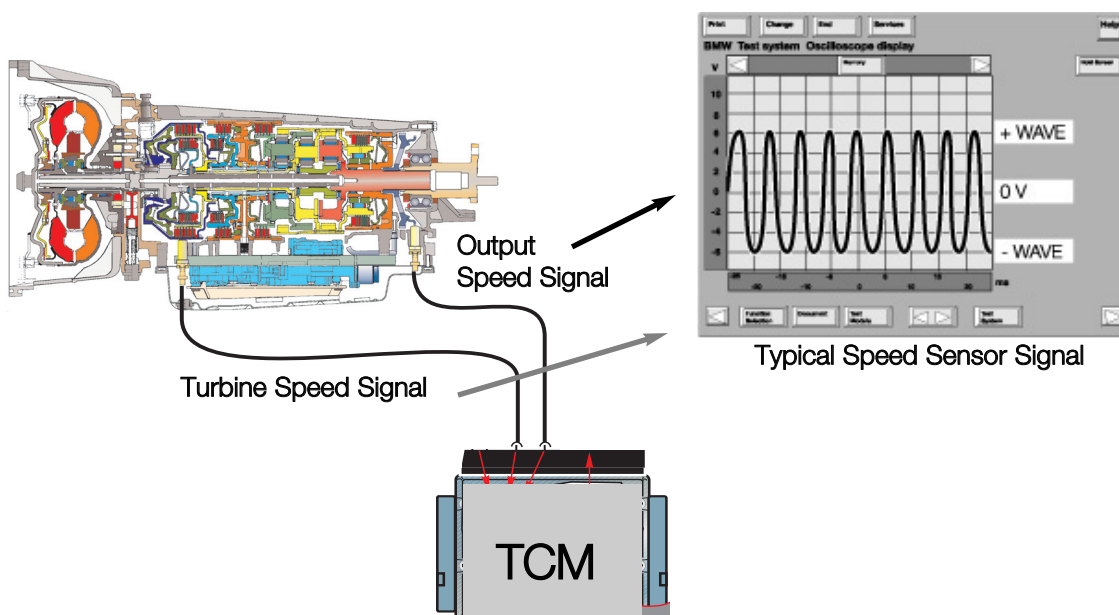

Speed Signal Worksheet

Task: Completely fill in the worksheet using instructor designated vehicle. Measure speed signals as instructed.

Chassis #: _____ Vehicle: _____

Transmission: _____ Control System: _____

Look up the Turbine and Output Shaft Speed Sensors in the ETM and record the following information:

Turbine Speed Sensor:

TCM Connector #: _____ Pins: _____ and _____

Output Shaft Speed Sensor:

TCM Connector #: _____ Pins: _____ and _____

Measure the resistance of the Turbine Speed Sensor and record below:

Actual Reading: _____ Specified Value: _____

Measure the resistance of the Output Shaft Speed Sensor and record below:

Actual Reading: _____ Specified Value: _____

Using the Oscilloscope Feature of the DISplus or GT-1, measure the signals from the Turbine and Output Shaft Speed Sensors.

Scope Settings: Voltage Range _____ Volts AC or DC Frequency _____ Hertz

What type of signal is generated by the Turbine Speed Sensor? _____

What type of signal is generated by the Output Shaft Speed Sensor? _____

What fault codes are set for Speed Sensor Failures? _____

Notes : _____

Transmission Oil Temp Sensor

The TCM is provided with transmission oil temperature information via a temperature sensor. On most BMW transmissions, the sensor is an NTC element which is part of the transmission internal wiring harness.

4HP22/24 (EH): These transmissions do not use a transmission oil temperature sensor. There are no transmission oil temperature influenced features on the 4HP transmissions.

All Except A5S360/390R, GA6HP26Z: The transmission fluid temp sensor is part of the transmission internal wiring harness. On these transmissions, the sensor cannot be replaced separately. The harness must be replaced.

A5S360/390R transmission: the sensor is a separate, replaceable sensor that can be unplugged from the harness.

GA6HP26Z: the sensor is located in the Mechatronics Module, which is located inside of the transmission.

Note: The Mechatronics Module is not currently serviceable at this time. Contact the BMW Technical Hotline in the event of a failure. Do not attempt any repair or replacement of the Mechatronics Module.

The transmission oil temperature information is used to:

- Initiate the Warm Up Program
- To inhibit TCC operation until a specified temperature has been reached.
- For determining fluid level when used with diagnostic equipment.

The transmission oil temperature sensor is connected to the TCM via a 5 Volt reference and a circuit ground. As transmission oil temperature increases, the circuit resistance and voltage decrease proportionately.

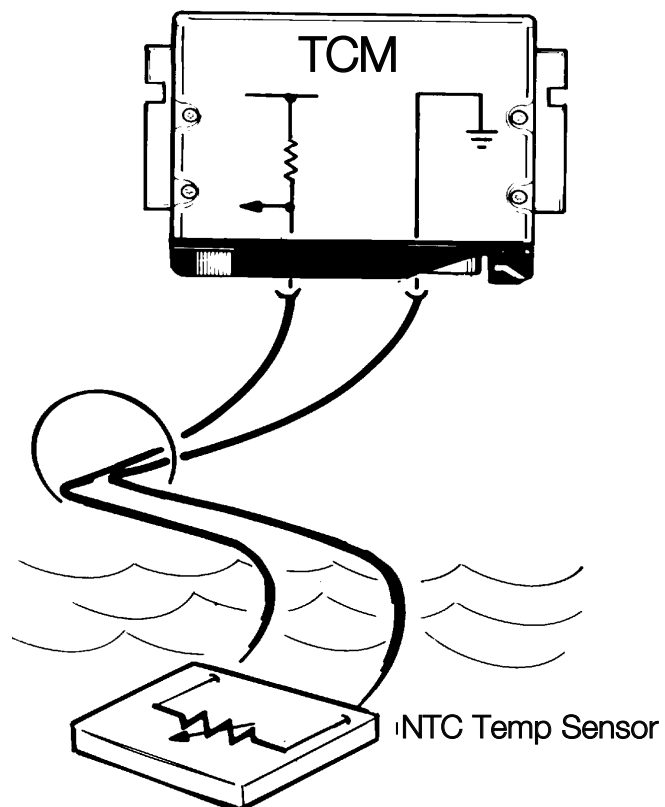

Kickdown Switch

The TCM receives a kickdown request via one of two possible methods:

- The kickdown signal is a direct ground input to the TCM. The kickdown input is provided by a kickdown switch located under the accelerator pedal. This method is used on most BMW vehicles without electronic throttle control systems (except M52TU with MDK).

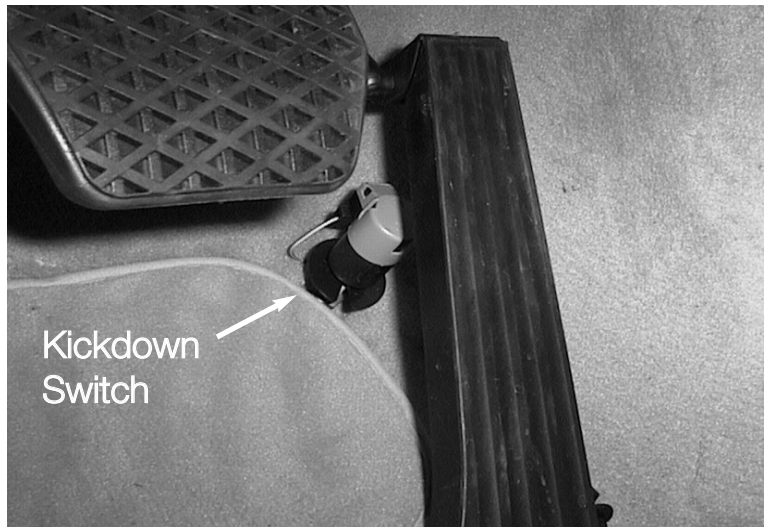

- The kickdown request is provided by the ECM (DME) via the CAN bus. The kickdown request originates from the PWG. There is no separate switch in the PWG. When the PWG voltage reaches approximately 4.5 volts, the ECM will process a kickdown request to the TCM via CAN. The PWG contains a kickdown detent to simulate the feel of a kickdown switch. This method is used on the M62TU, M54, M73, M73TU, N73 and N62 engines.

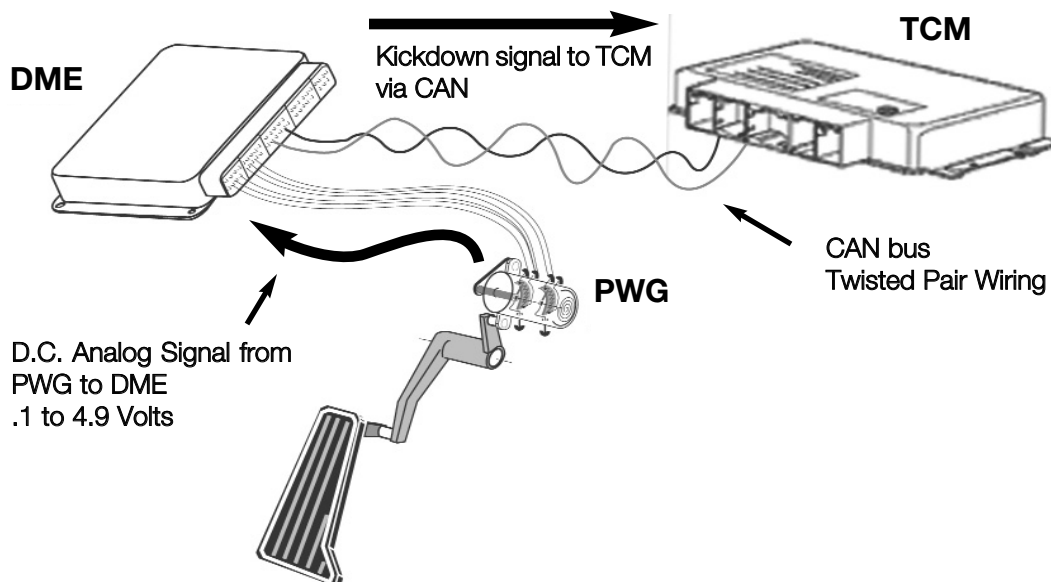

Brake Switch

The brake switch is located on the brake pedal linkage. The brake switch signal is an input to the TCM which is used for:

- De-activation of the shift lock solenoid. When the ignition key is turned to KL15 the shift lock is active. The shift lock solenoid is de-activated when the brakes are applied.
- De-activate the Torque Converter . The TCC is deactivated whenever the brake is applied. (only on Hydramatic Transmissions).

There are two types of brake switches used on BMW vehicles:

- On early vehicles such as E32, E34, E36, E24, E28 and E31 the brake switch is a double-contact mechanical switch. There is a brake light circuit and a brake test circuit. The brake test circuit is used for a plausibility check to indicate faults within the brake light circuit.
- On the E38, E39, E46, E65/66, E85 and E53 the brake switch is a hall effect type switch. The electronic switch is also monitored for faults and plausibility.

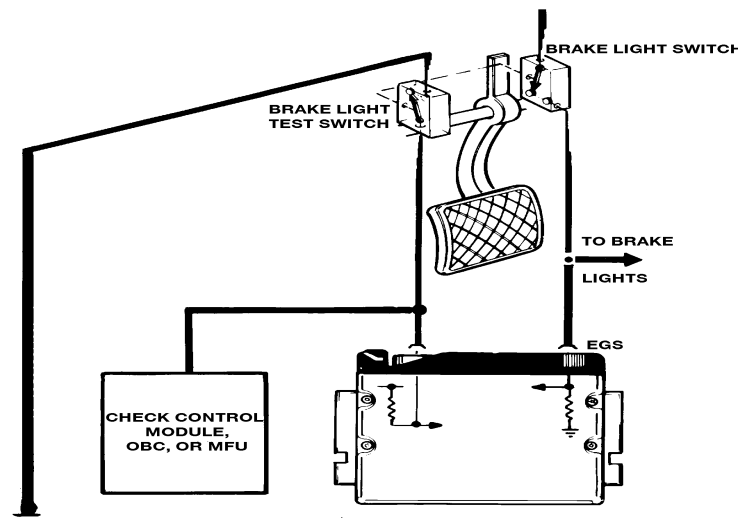
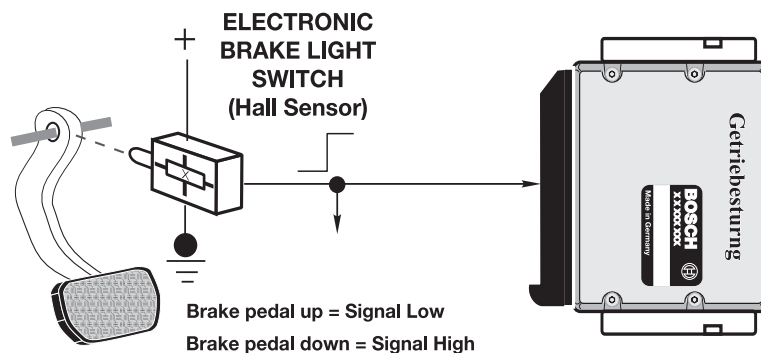

Input Signal Worksheet

Task: Completely fill in the worksheet using instructor designated vehicle.

Chassis #: _____ Vehicle: _____

Transmission: _____ Control System: _____

Transmission Temp Sensor

Where is the transmission oil temp sensor located? _____

What is the reference voltage for this circuit? _____

Note the current temperature on Status Requests and measure the input voltage at the TCM:

Transmission Temperature: _____ Input Voltage: _____

What does the input voltage do when transmission temperature goes up?

Kickdown Switch/Circuit

Describe the Kickdown Switch circuit in this vehicle:

Brake Switch

List the pin and connector of the TCM that receives input from the brake switch?

Connector # _____ Pin # _____

What is the brake switch used for in this transmission?

Notes:

Transmission Range Selector Switch

The range selector switch is an input to the TCM. The input is used by the TCM to determine the position of the manual valve. The range switch uses the familiar “coded input” signal to determine selector lever position. On all transmissions except the A5S360/390R, the range switch uses a 4 wire configuration to determine 7 range selector positions. The A5S360/390R uses a five wire arrangement.

Most range switches are located on the transmission case with some exceptions. The E36 with the A4S270/310R the range switch is located in the center console on the selector lever assembly. The E39 with A4S270R the range switch is located on the transmission case and is adjustable. The range selector switch on the A5S360/390R is located inside the transmission housing. GA6HP26Z is part of the Mechatronics Module.

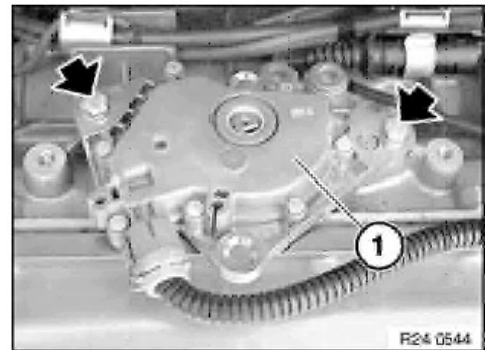

Range Switch A5S440Z

The range switch can be checked by using “Status Requests” in the DISplus or GT-1. A multimeter or an oscilloscope can also be used to check the range switch. If the reading on “Status Requests” does not match the actual selector lever position, there will be various transmission malfunctions.

Always refer to the proper ETM when diagnosing the range selector switch. Use the switch logic chart to diagnose faults in the switch.

In the example below, the range switch is in neutral. Using the logic chart, switches L1, L2 and L3 are closed providing B+ voltage to the corresponding pins of the TCM. Switch L4 is open and no voltage is sent to the TCM. Malfunctions in the range switch or wiring can cause various shifting complaints and possible No-Start complaints.

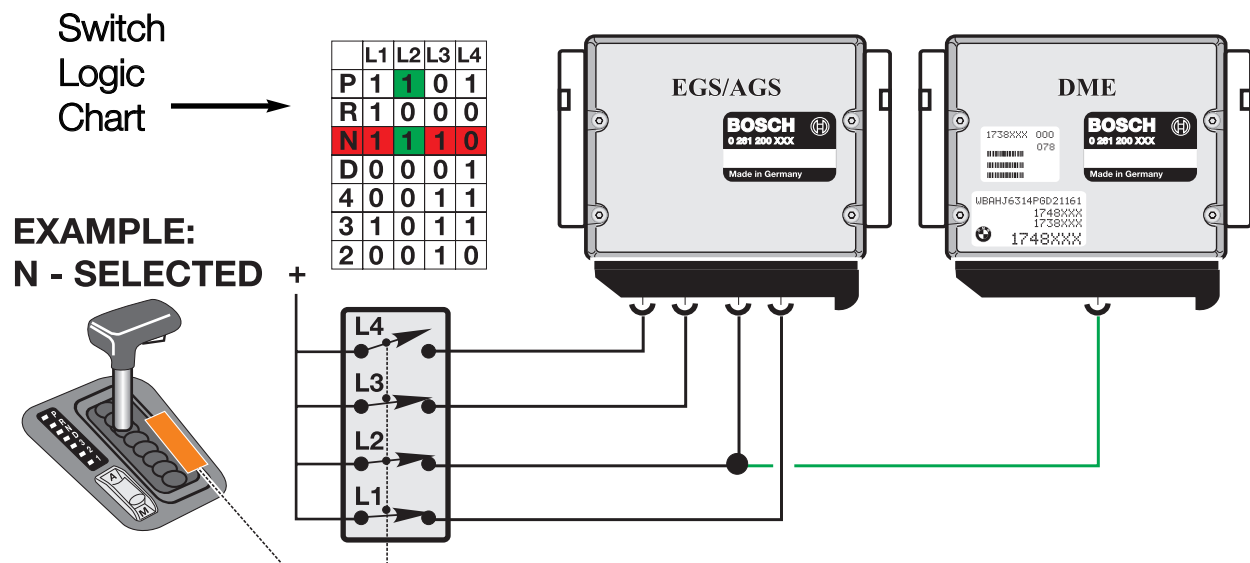

Transmission Range Selector Switch Worksheet

Task: Completely fill in the worksheet using instructor designated vehicle. Use ETM and insert actual voltage readings in chart below.

Chassis #: _____ Vehicle: _____

Transmission: _____ Control System: _____

Where is the Range Selector Switch Located on this transmission?

List any Service Information Bulletins that pertain to Range Selector Switch issues:

Using the correct ETM for this vehicle, complete the switch logic chart below. Connect Breakout Box to TCM and insert the observed voltage readings:

Notes:

| | L1 | L2 | L3 | L4 | L5 (GM5) |
|---|----|----|----|----|-------------|
| P | | | | | |
| R | | | | | |
| N | | | | | |
| D | | | | | |
| 4 | | | | | |
| 3 | | | | | |
| 2 | | | | | |

Transmission Program Switch

The transmission program switch is used to switch between various operating modes of the transmission. The normal default mode of the TCM is Economy which is indicated in the program display as “E”. Economy mode allows the transmission to operate in the most efficient mode. Shift priorities are for maximum economy and shift comfort. On some vehicles the program switch is designated “A” for economy mode. Program switches come in 2 or 3 position configurations. Early vehicles with the 4HP (Early E7) used a rotary program switch.

The TCM can also be switched to “Manual Mode” which on some vehicles is designated “Winter Mode”. Manual mode is used to start the vehicle off in a higher gear when encountering slippery conditions. The program display will indicate “M” (manual) or an asterisk symbol for “Winter Mode”.

Sport Mode is the third operating mode that is available. Sport mode allows for a slightly delayed and more aggressive shift. Sport mode is obtained a number of ways. On vehicles with 2 position program switches, moving the selector lever out of drive to 4,3, or 2 with the program switch in Economy will allow Sport mode. On vehicles with 3 position program switches, Sport mode can be obtained by switching to “S”.

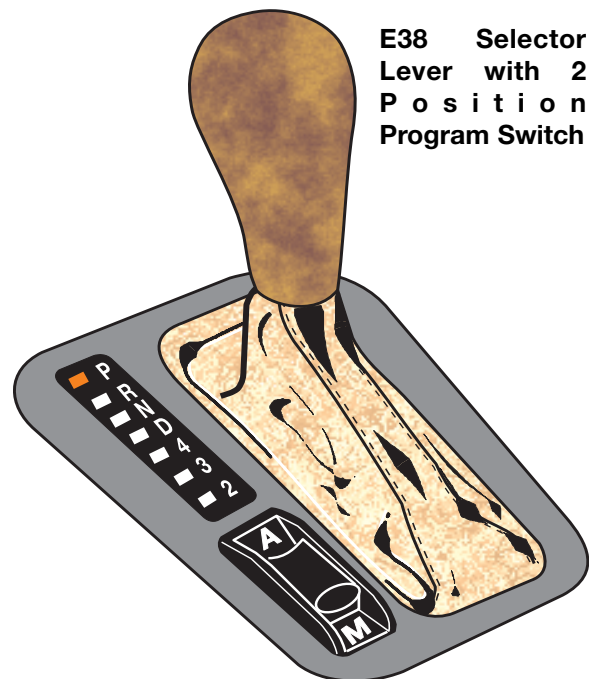
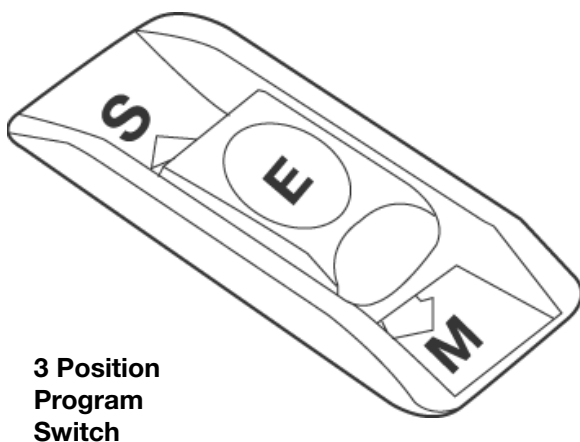

Steptronic Components

The Steptronic system uses additional components not found on a conventional system. These components consist of a manual switch and an Up/Down microswitch. Otherwise, the Steptronic system uses the same transmission and TCM.

The TCM monitors the Steptronic shifter position from P through D via the conventional range selector switch located on the transmission. The Range Selector Switch provides positions P through D to the TCM because the automatic gate of the shifter only travels through these positions.

When the Steptronic Shifter is moved to the left 15 degrees into the manual gate, the TCM receives a ground input from the manual gate switch. The ground signal is provided to the TCM through the Transmission Position Indicator. The transmission position indicator also provides range position signaling to the range position indicator in the shift console.

Steptronic was introduced on the E31 850Ci (10/94) and the 840Ci (1/96). Steptronic was subsequently introduced into the E38, E39, E46, E36/7 and the E53.

The Steptronic system can be diagnosed through "Status Requests" with the DISplus or GT-1.

Refer to TRI Bulletin B 24 75 96 for more information on Steptronic.

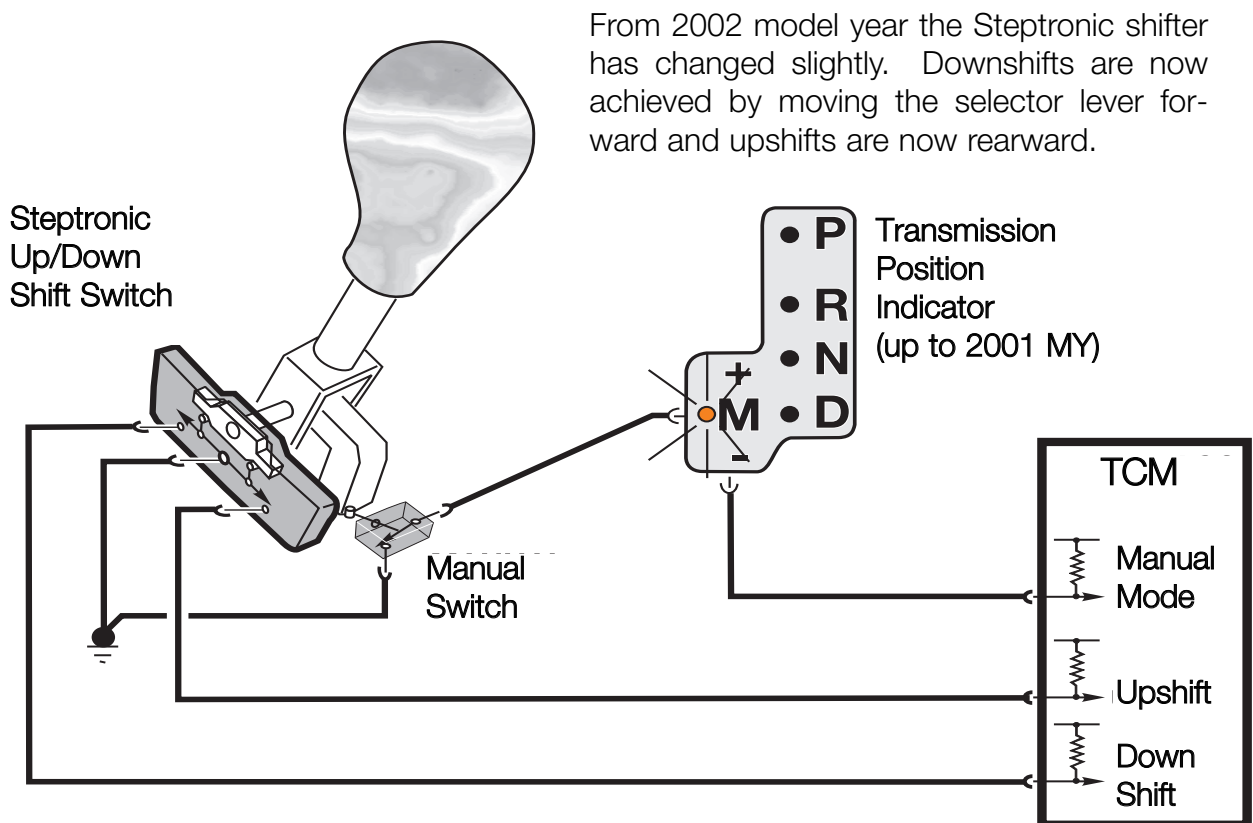

Transmission Program Switch /Steptronic Worksheet

Task: Completely fill in the worksheet using instructor designated vehicle.

Chassis #: _____ **Vehicle:** _____

Transmission: _____ **Control System:** _____

Is this vehicle equipped with a Program Switch or Steptronic? _____

Steptronic

List the inputs to the TCM from the Steptronic Switches:

What type of signal comes from the Steptronic Switches?

What is the shift pattern used on this model?

Notes:

Mechatronic Module GA6HP26Z

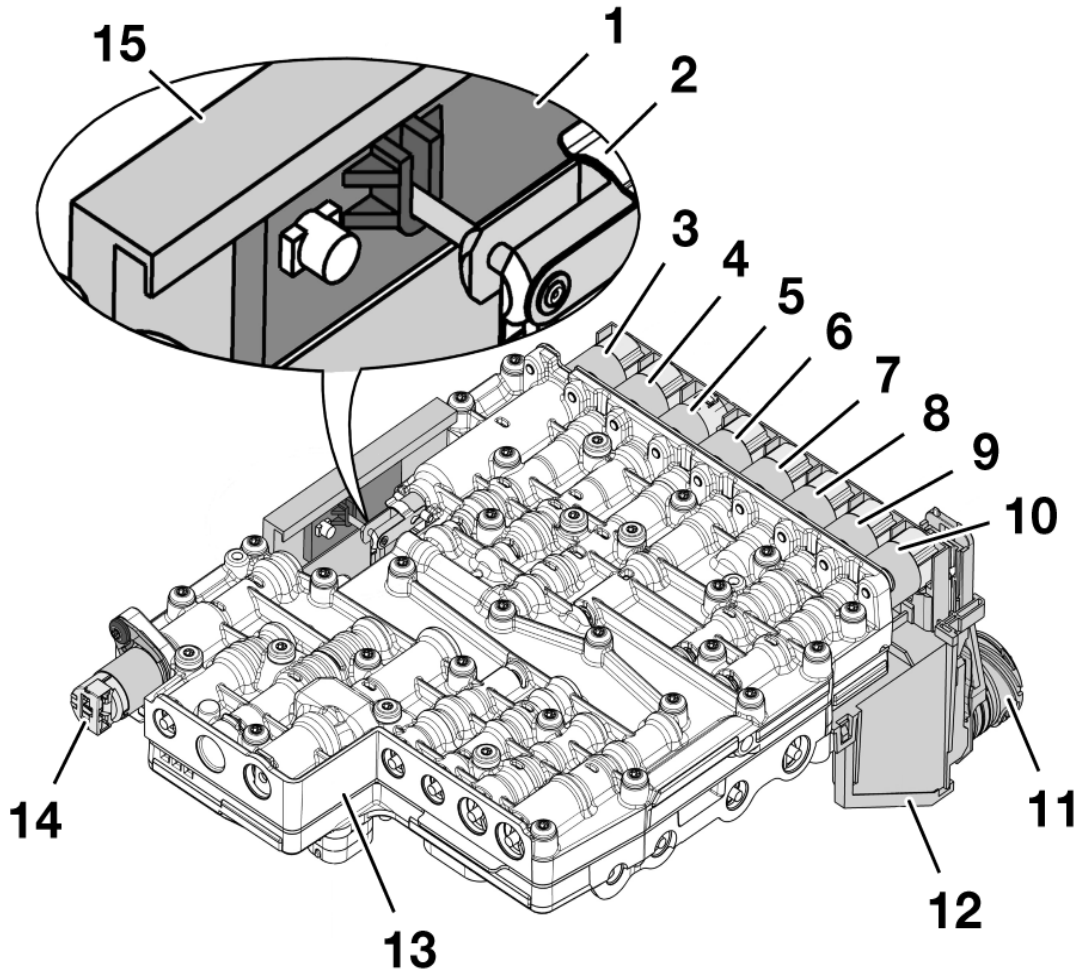

| | | | |
|----------|---|-----------|-------------------------------|
| 1 | Position Slide Switch | 9 | EDS 2 |
| 2 | Parking Lock Cylinder Piston | 10 | EDS 1 |
| 3 | Solenoid Valve 3, parking lock Cylinder | 11 | Electronic Plug Connector |
| 4 | EDS | 12 | Electronic Module |
| 5 | Solenoid Valve 1 | 13 | Hydraulic Module (Valve body) |
| 6 | EDS 4 | 14 | Solenoid Valve 2 |
| 7 | EDS 5 | 15 | Position Switch |
| 8 | EDS 3 | | |

Magnetic Valves

Magnetic Valves (MV) are used to electronically control hydraulic fluid flow to the various shift elements within the transmission. Magnetic valves are located on the valvebody and replaceable as separate components. In ZF transmissions, MV valves are designated MV1, MV2, MV3 etc. In Hydramatic transmissions, they are designated Shift Valve A, Shift Valve B, Shift Valve C etc.

The magnetic valves are controlled by the TCM. They are supplied power by an internal TCM relay and are ground controlled. The TCM switches one or more of the MV's on or off in various combinations to achieve various shifts. Most transmission have 2 or 3 MV's to control shifting.

In addition to controlling shifts within the transmission, magnetic valves are also used for overlap shifting and pressure regulation on some transmission applications. For example MV4 and MV5 are used for overlap shifting in the A5S310Z. MV5 is used for pressure regulation on the 4HP22/24EH transmissions. When used for pressure regulation, the magnetic valves are pulse width modulated by the TCM.

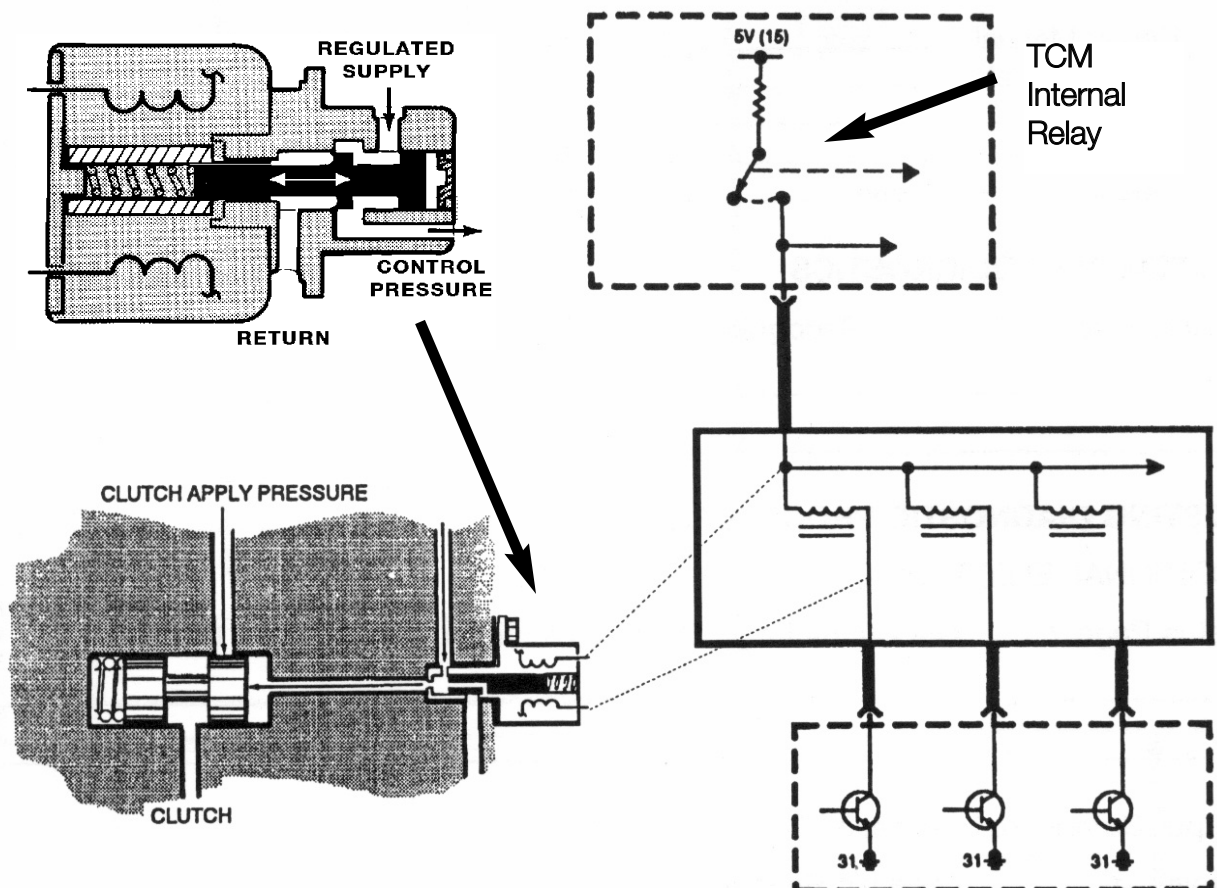

Pressure Regulating Solenoids

Pressure Regulating Solenoids are used to modify line pressure for use in the transmission. There are numerous terms for these solenoids depending upon transmission type and manufacturer. ZF transmissions use the term EDS, while Hydramatic Transmissions use the term DR solenoid, Force Motor Solenoid and Variable Bleed Solenoid (VBS).

EDS valves are used for main line pressure regulation, TCC application and Overlap Shift Pressure Control on the A5S440Z and A5S560Z. All pressure regulating solenoid are controlled by Pulse Width Modulation.

Using the example in the picture below, this is a section of the A5S440Z/560Z valve body. The EDS valves are used for the following:

- EDS 1 is used for main line pressure regulation
- EDS 2, 3 and 5 are used Overlap Shift Pressure Control
- EDS 4 is used for TCC application. (GWK) Gradually applied TCC.

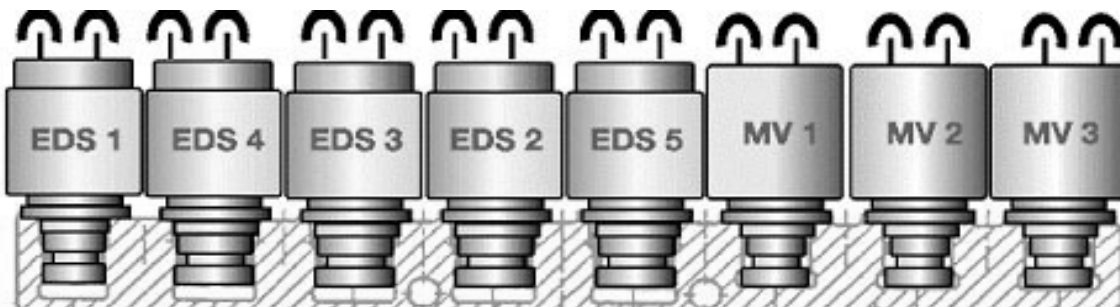

Hydramatic Pressure Regulator

The valve body shown at the right is from the A5S360/390R. Note the location of the main pressure regulator. Depending upon the reference text, the pressure regulator is also known as the Force Motor Solenoid, Variable Bleed Solenoid or PC Solenoid.

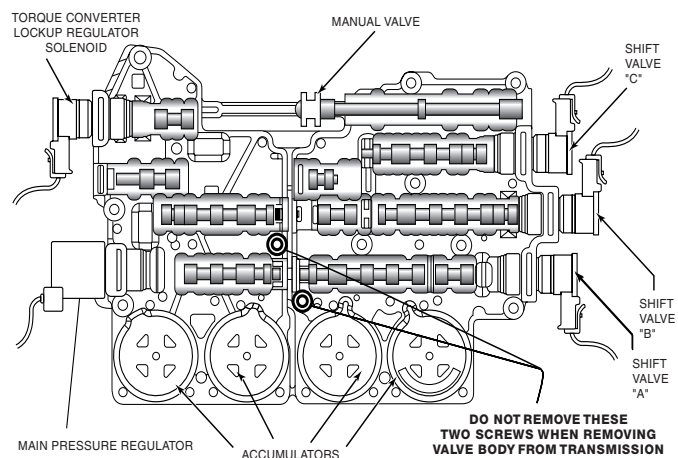

Valve Body Worksheet A5S440/560Z

Task: Completely fill in the worksheet using instructor designated vehicle. Insert actual resistance readings in the chart below.

Chassis #: _____ Vehicle: _____

Transmission: _____ Control System: _____

| | Purpose | Resistance Specification | Actual Resistance |
|--------------|---------|--------------------------|-------------------|
| EDS 1 | | | |
| EDS 2 | | | |
| EDS 3 | | | |
| EDS 4 | | | |
| EDS 5 | | | |
| MV 1 | | | |
| MV 2 | | | |
| MV 3 | | | |

What is the proper torque value for the valvebody to transmission case bolts?

What special tools (Test cable / B.O.B.) is used to measure solenoid resistance from the “cannon” connector?

When does valve body removal become necessary?

Valve Body Worksheet A5S440/560Z

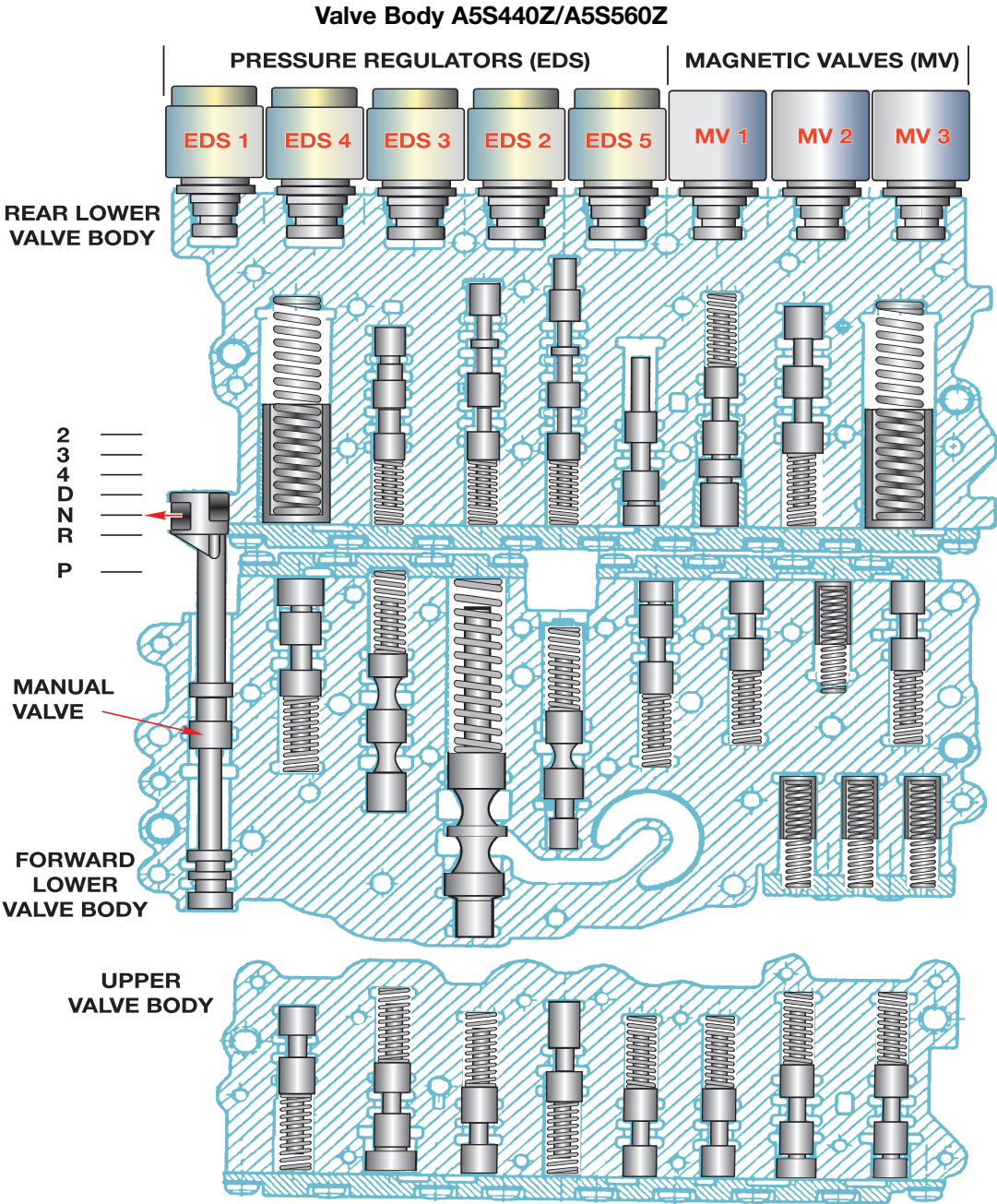

Using repair instructions, circle the bolts on the diagram that are to be removed to replace the valve body (shift unit)

Valve Body Worksheet A5S360/390R

Task: Completely fill in the worksheet using instructor designated vehicle.

Chassis #: _____

Vehicle: _____

Transmission: _____

Control System: _____

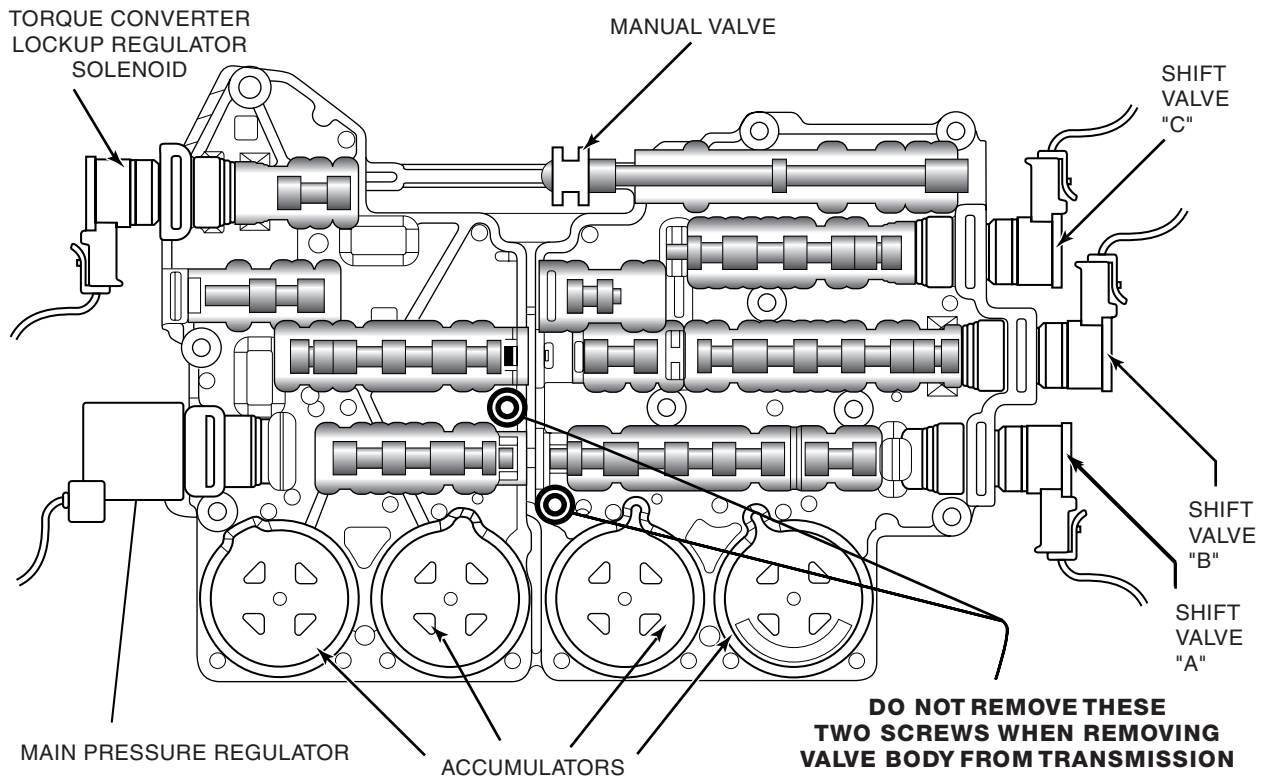

| | Purpose | Resistance Specification | Actual Resistance |
|---------------|---------|--------------------------|-------------------|
| Shift Valve A | | | |
| Shift Valve B | | | |
| Shift Valve C | | | |
| TCC Solenoid | | | |
| Press Reg. | | | |

What is the torque specification for the valve body to transmission case bolts on the A5S360/390R (GM5)?

Valve Body Worksheet A5S325Z

Task: Completely fill in the worksheet using instructor designated vehicle.

Chassis #: _____ Vehicle: _____

Transmission: _____ Control System: _____

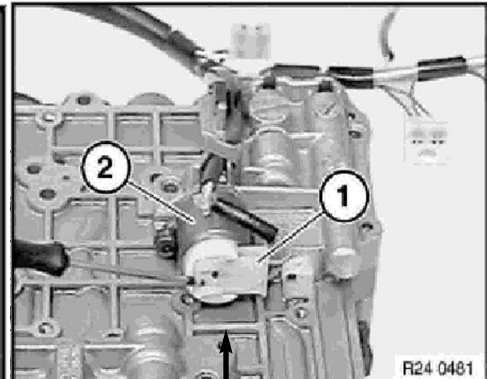
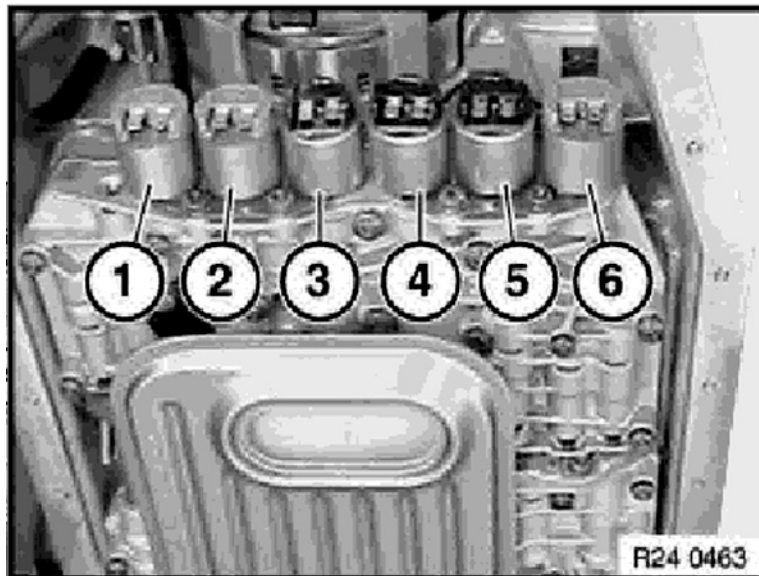

Note: The Valvebody must be removed in order to access EDS1

- 1 - EDS Connector
- 2 - EDS 1 (Pressure Regulator)

| | Purpose | Resistance Specification | Actual Resistance |
|----------------------------|---------|--------------------------|-------------------|
| Solenoid Valve 1 (MV) | | | |
| Solenoid Valve 2 (MV) | | | |
| Solenoid Valve 3 (MV) | | | |
| Pressure Regulator 1 (EDS) | | | |
| Pressure Regulator 2 (EDS) | | | |
| Pressure Regulator 3 (EDS) | | | |
| Pressure Regulator 4 (EDS) | | | |

Instrument Cluster

The cluster is used to report information to the driver regarding transmission status. There are three items of information needed by the driver:

- **Transmission Range** - this indicates the position of the range selector lever. The driver needs to know whether the transmission is in P, R, N, D, 4, 3, or 2.
- **Transmission Program** - this indicates the mode of operation. There are 3 modes, Economy, Manual and Sport .
- **Transmission Fault Information** - the driver needs to know of there is a malfunction in the transmission. Depending upon application, transmission faults can be indicated by an icon or by a “Transmission Program” message in the instrument cluster display matrix.

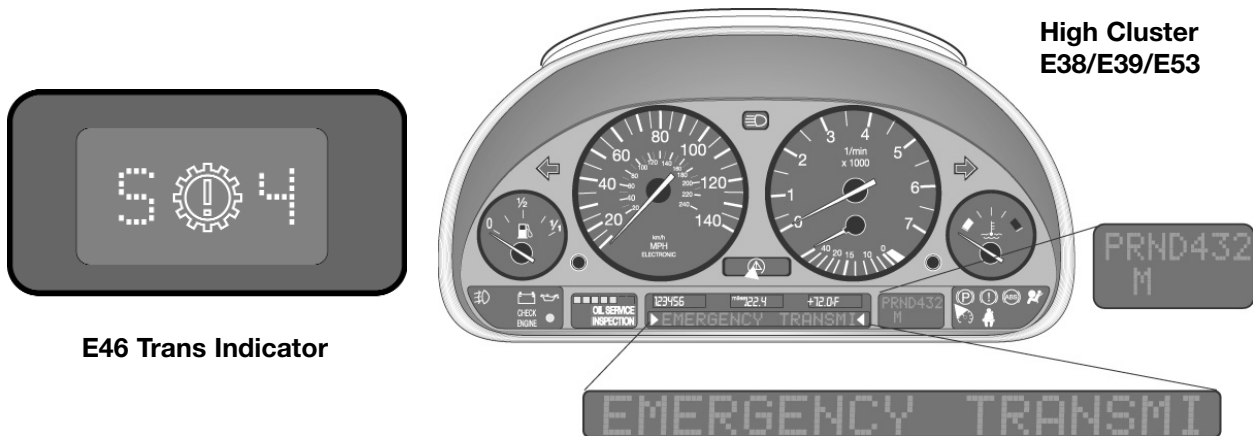

Depending upon vehicle model and transmission, these pieces of information arrive at the cluster through different methods.

- The most current method for this information to arrive at the cluster is through the CAN bus. The cluster processes this information from the TCM via CAN.
- On early E38 and E39 vehicles there is a “One Way Data Signal” from the TCM to the cluster. There is a one way serial data line that transfers this information to the cluster. On later vehicles, the cluster was introduced to the CAN bus and this method was no longer used. This was used on the E38 vehicles to 5/97 and E39 vehicles to 8/97 production.
- Early vehicles such as E32, E34, E36 etc. used a various combination of methods to transfer this data. Some clusters use the “Coded Input” method for the program indicator. Fault indication is done by a ground circuit through the TCM. Transmission range indication is achieved by a direct connection between the range switch and cluster or by a coded input to cluster.

There will be a FC6 in the Kombi when the TCM goes into failsafe mode.

When attempting to diagnose any of these circuits, always refer to the proper ETM.

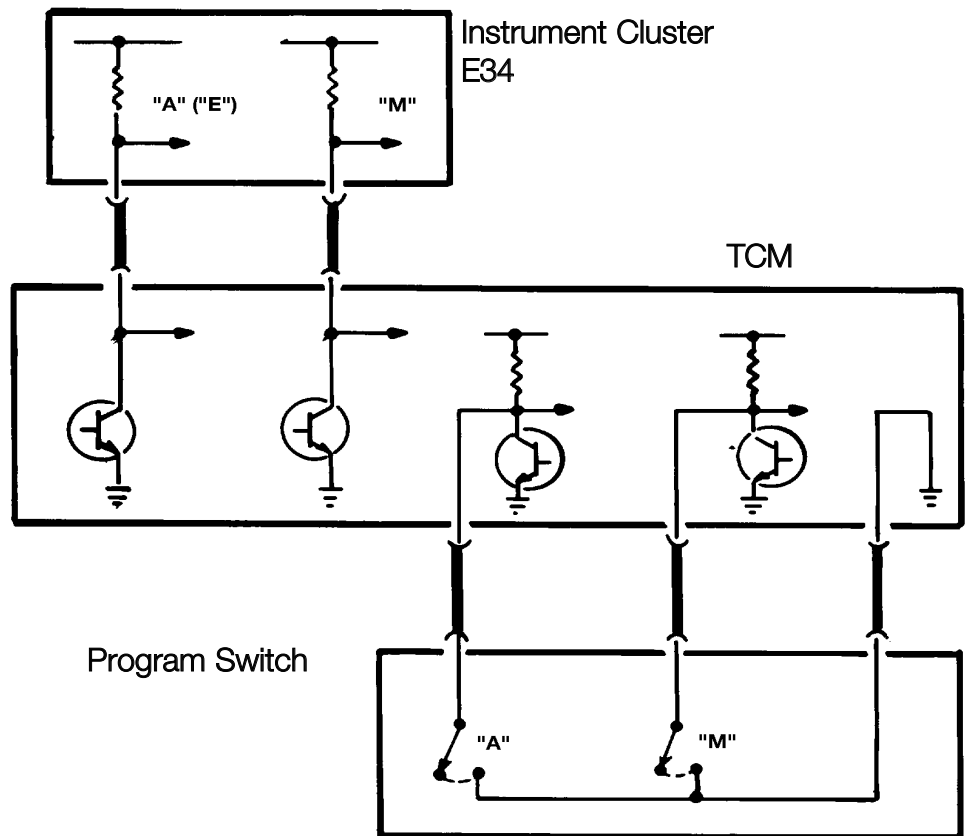
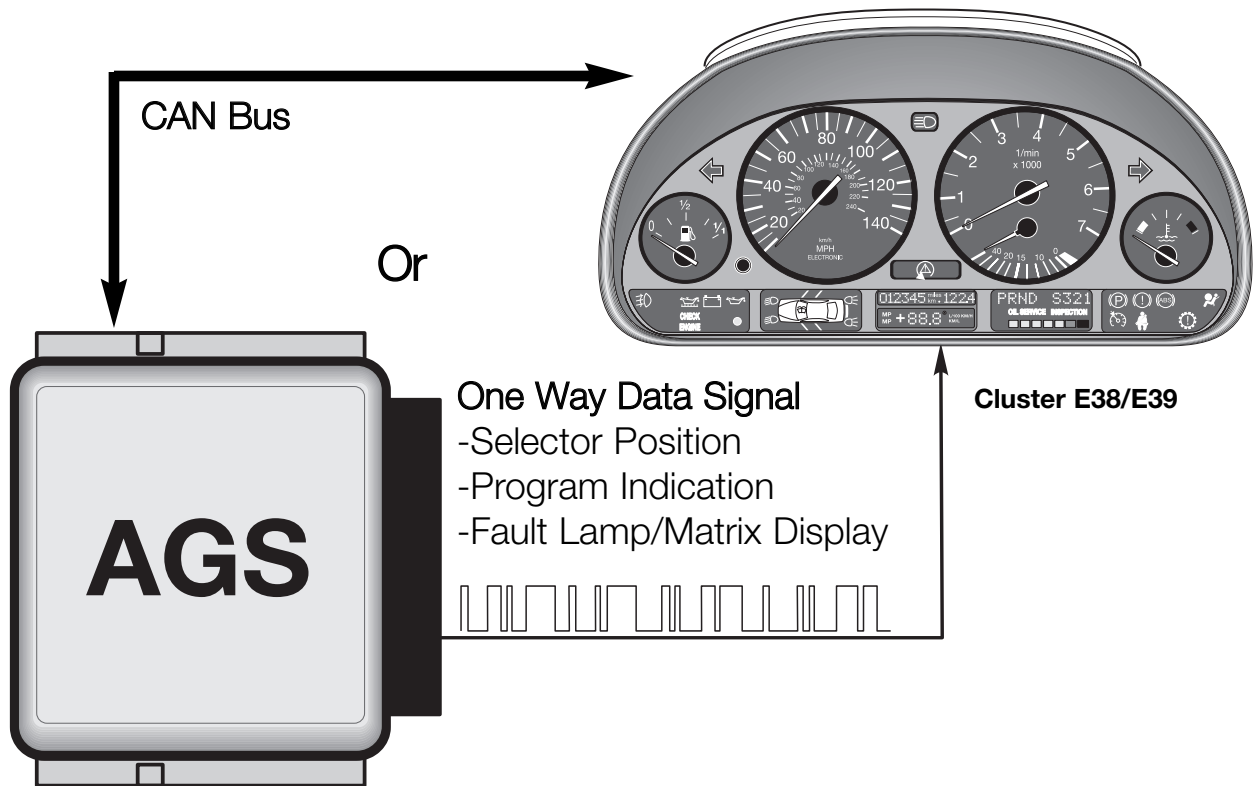

Transmission Features and Principles of Operation

Adaptive Hydraulic Pressure Control

Pressure adaptation has been a feature of ZF automatic transmissions since the 4HP22EH. The TCM will maximize shift quality by adapting to transmission wear over time. The TCM will adjust transmission shift pressures to compensate for wear in the multi-plate clutches. This is accomplished by monitoring the input and output speeds of the transmission. When the transmission shifts, the TCM monitors the time that it takes to accomplish the shift. The time change in gear ratio is monitored and compared to an internal time value in the TCM. If the ratio change takes more time than the stored value, the TCM will compensate by adjusting the transmission shift pressures via the EDS valve solenoids. The adaptation value is stored in the TCM. This adaptation values can only be cleared by the diagnostic tester (DIS plus or GT-1).

Note: DO NOT clear adaptation values unless directed to do so by technical assistance. Clearing pressure adaptations should not be done to resolve a customer complaint. The only time that you would need to do so is after a transmission or valve body replacement or software change.

Also it is important not to confuse pressure adaptation with AGS features. AGS features will be discussed later in this chapter. AGS features are not stored on a long term basis and will not be cleared when the pressure adaptations are cleared. Note: Driving style is NOT stored.

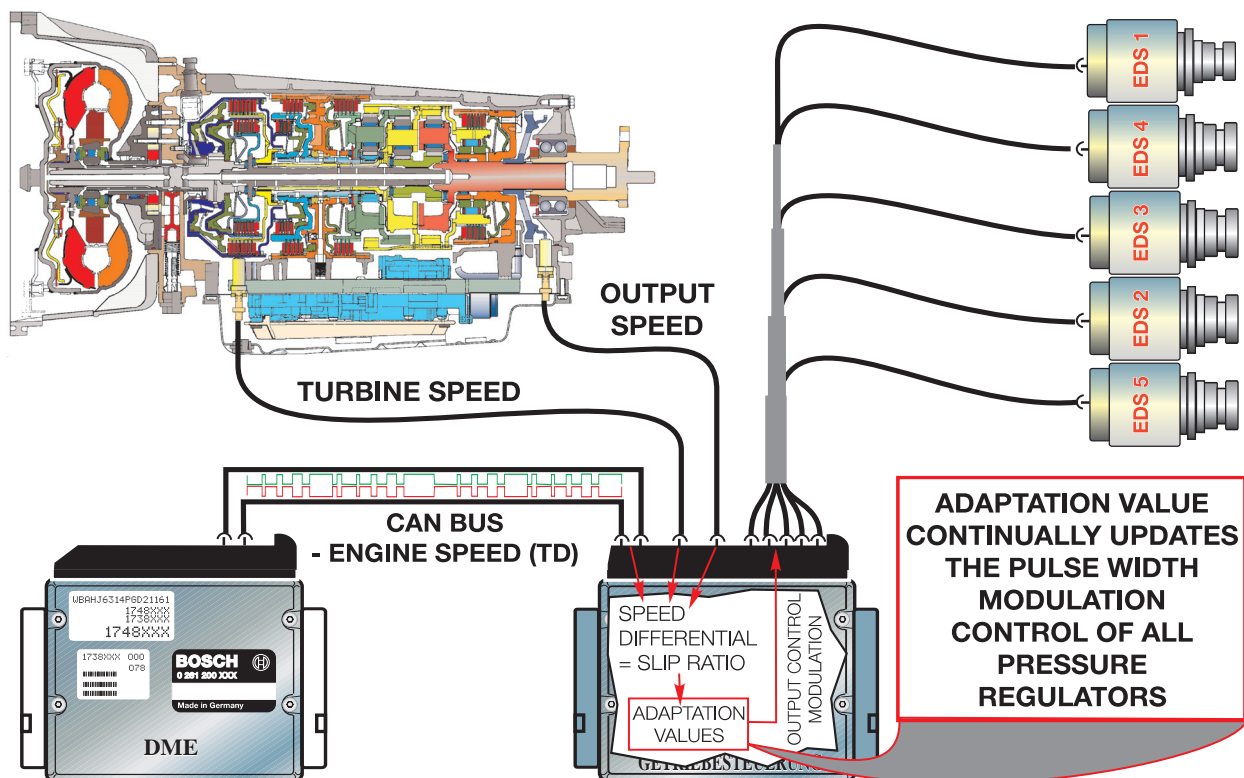

Downshift Protection

Downshift protection is a feature that prevents unwanted or improper downshifting. If the range selector were moved to a lower gear at a high road speed, engine damage could occur from an unintended over-rev. This feature will prevent engine over-rev by delaying or preventing the unwanted downshift until the proper road speed is achieved. The result is increased safety by preventing unwanted deceleration slip.

Reverse Lockout

The TCM will lockout reverse above 3 MPH to prevent drivetrain damage. The range selector lever will go into the reverse detent, but reverse will not engage. This is achieved by the TCM through hydraulic intervention. The transmission will appear to be in neutral.

Note: Reverse Lockout is not operative when in failsafe.

Engine Warm Up Cycle

The transmission shift points are modified after cold start to raise engine RPM during shifting. This allows for a faster engine warm up and reduction of catalyst warm up time. The TCM uses the transmission oil temperature information to determine the implementation of this function.

The warm up phase program will be terminated if any of the following conditions exist:

- The vehicle exceeds 25 MPH or
- Transmission oil temperature exceeds 60 Degrees Celsius or
- A Maximum of three minutes is exceeded.

ASC/DSC Shift Intervention

During ASC/DSC regulation upshifts are inhibited to enhance the effectiveness of tractional control. Depending upon vehicle model, this action can take place via the CAN bus or a dedicated shift intervention signal wire. On later model vehicles where the ASC/DSC module is connected to the CAN bus, the shift intervention signal is sent to the TCM via CAN.

Torque Reduction

In order to allow a smoother shift and reduce load on the transmission, engine torque is reduced during shifting. This is accomplished by a signal that is sent from the TCM (EGS) to the ECM (DME) during shifting. The ECM will retard timing momentarily during the shift for a few milliseconds. This timing change is transparent to the driver. Depending upon application, the torque reduction signal is sent over a dedicated wire or a signal over the CAN bus.

Emergency Program

When a malfunction occurs within the transmission, the Emergency program (failsafe mode) will be initiated. The Emergency Program will prevent unintended gear engagement and ensure driver safety. The following will occur during Failsafe Operation:

- All shift solenoids are de-energized via TCM internal relay.
- The pressure regulation solenoid is de-energized resulting in maximum line pressure.
- The Torque Converter Clutch is de-activated.
- The Reverse Lockout function is cancelled.
- Shift lock solenoid is de-energized.
- Fault indicators are active.

The fault indicator varies depending upon model, year and cluster type etc. High version instrument cluster will display a message in the matrix display. Vehicles with low version clusters will display a fault symbol in the cluster.

During failsafe mode the transmission will be shifted into a higher gear to allow the vehicle to be driven to a service location. Depending upon application, the transmission will shift into 3rd or 4th gear (on a 4spd) and 4th or 5th gear (on a 5 spd). For example the A5S360R transmission will go into 5th gear when there is a malfunction and 4th when there is a power failure to the TCM. Since pressure regulation ceases, the shift to failsafe mode will be abrupt or harsh, unless the transmission is already in the failsafe gear.

On newer OBD II compliant vehicles, the MIL light will also be illuminated by the ECM (DME).

Note: When diagnosing transmission related complaints, it is possible to have an erroneous fault indicator warning. Faults in the cluster can cause a false indication or “Trans Program” message. One indication of this scenario would be a transmission fault message in the cluster with no transmission faults stored in the TCM.

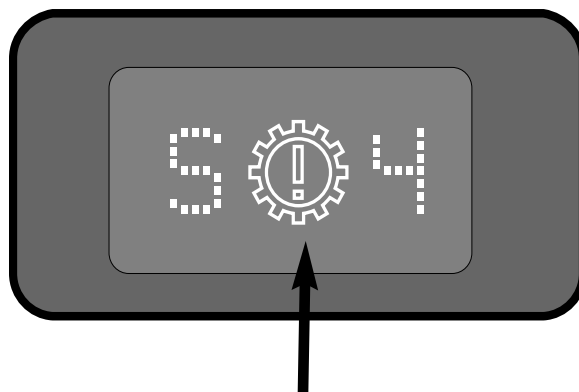

E46 Transmission Fault Indicator

AC Compressor Load Sensing (Hydramatic Transmissions)

When the AC Compressor is switched on, additional load is placed on the engine. To compensate for the additional load, the TCM modifies line pressure and shift points. On the THMR-1, the TCM receives these signals via a direct connection to the AC compressor control circuit.

On vehicles equipped with CAN bus technology, the “AC on” signal is sent to the TCM from the DME as a CAN bus message.

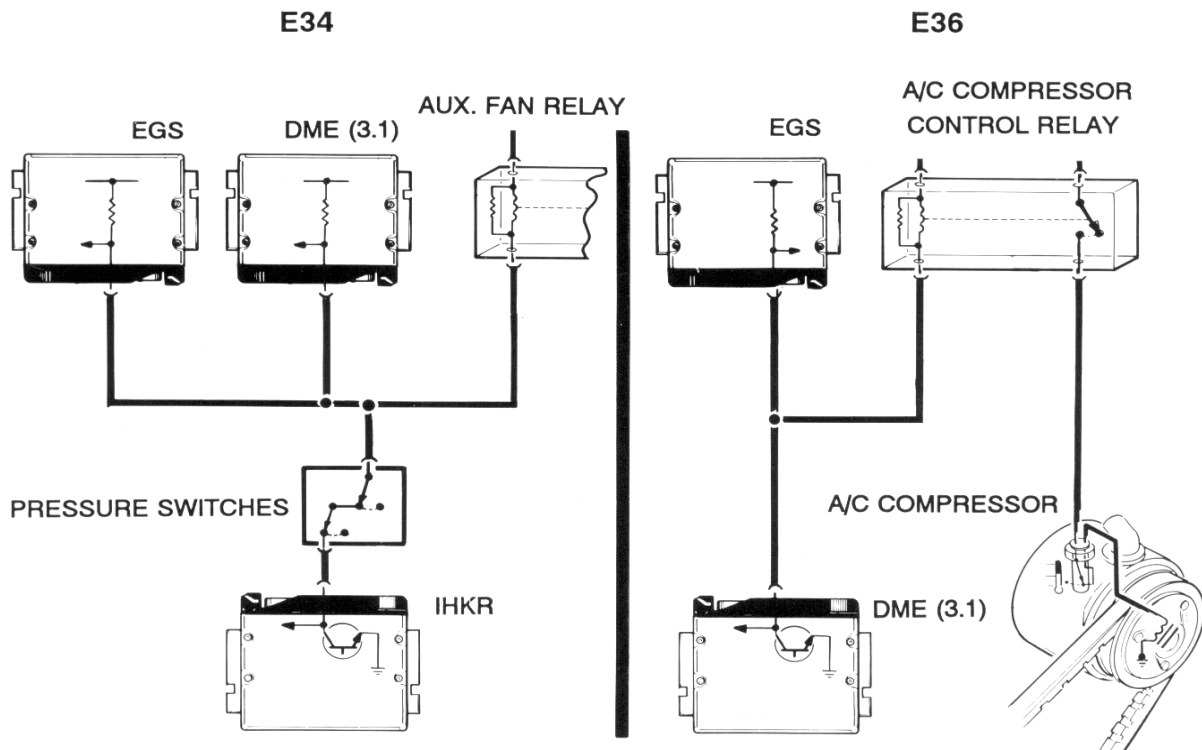

Shift Lock

The shift lock solenoid is mounted on the selector lever assembly and locks the selector lever in Park or Neutral when the ignition is ON. This prevents the selection of a gear unless the brake pedal is depressed. The solenoid is activated by a switched ground from the TCM. Power is supplied by the TCM internal relay. During failsafe operation, the shift lock is disabled. On later models, the shift lock will also be active when the TD signal is present and the shifter will remain locked above an engine speed of 2500 RPM regardless of brake application.

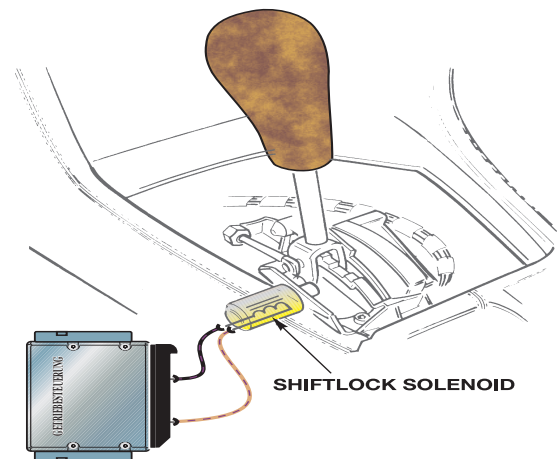

Torque Converter Clutch

Since the efficiency of the torque converter at coupling speed is approximately 1.1 to 1, fuel economy is compromised. To offset this a torque converter clutch was added on EH controlled transmissions. The torque converter clutch locks the turbine to the converter housing. This creates a mechanical coupling with a ratio of 1:1. This can only be achieved at higher engine speeds, the torque converter clutch must be disengaged at low engine speeds to prevent stalling.

There are two methods for controlling the torque converter clutch on BMW transmissions:

- **A4S310/270R, 4HP22/24 EH, A5S310Z** - These transmissions use an on/off control method to lock and unlock the torque converter. The Torque Converter Clutch is either completely engaged or disengaged. This method of engagement provides an abrupt sensation when the TCC is locking and unlocking. This abrupt sensation can be undesirable to some drivers.
- **A5S560Z, A5S440Z, A5S325Z, GA6HP26Z, A5S360/390R** - These transmissions use a gradual approach to TCC control. The TCC is gradually applied and released, this method reduces the abrupt feel of the on/off type TCC. The TCC solenoid is controlled by pulse width modulation. This allows fluid to be gradually introduced and released to the TCC.

The TCC is spring loaded to the engaged position. Pressurized fluid releases the TCC, when the pressurized fluid is released, the TCC is engaged. Depending on transmission application, the TCC can be engaged in 3rd, 4th or 5th gear. The TCC must be disengaged at low speeds to prevent stalling.

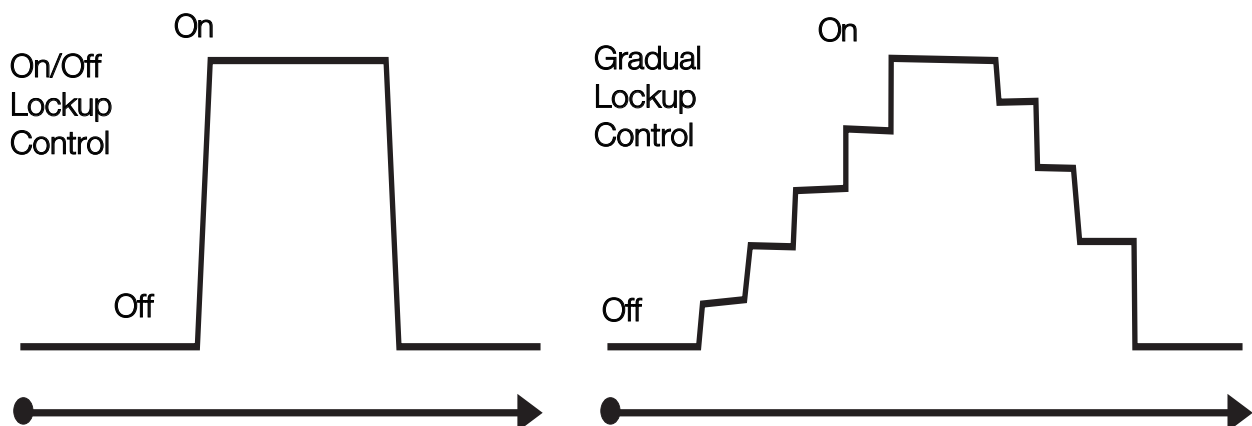

Shift Solenoid Control

Magnetic valves are used to direct the flow of transmission fluid to control shift elements in the transmission. Another Term for “Magnetic Valve” is “Shift Valve”. Magnetic valves (MV) are solenoids controlled by the TCM. They can be switched by B+ or B-.

On ZF transmissions, magnetic valves are designated MV1, MV2, MV3 etc. On GM transmissions they are designated Shift Valve A, Shift Valve B, Shift Valve C etc.

Either valve can be checked for proper resistance using a multi-meter, DISplus or GT-1. Also, the “Activate Components” function can be used to check the Magnetic valves. Most all magnetic valves are switched on/off instead of Pulse Width Modulation (PWM).

All magnetic valves (except THM R-1 to 12/95) are supplied power from an internal relay located in the TCM. The magnetic valves are switched on and off by final stage transistors in the TCM. During failsafe operation, power to all MV's is switched off by the internal relay.

Magnetic valves are located on the valve body. They can be replaced individually. Refer to proper repair instructions for installation and removal procedures.

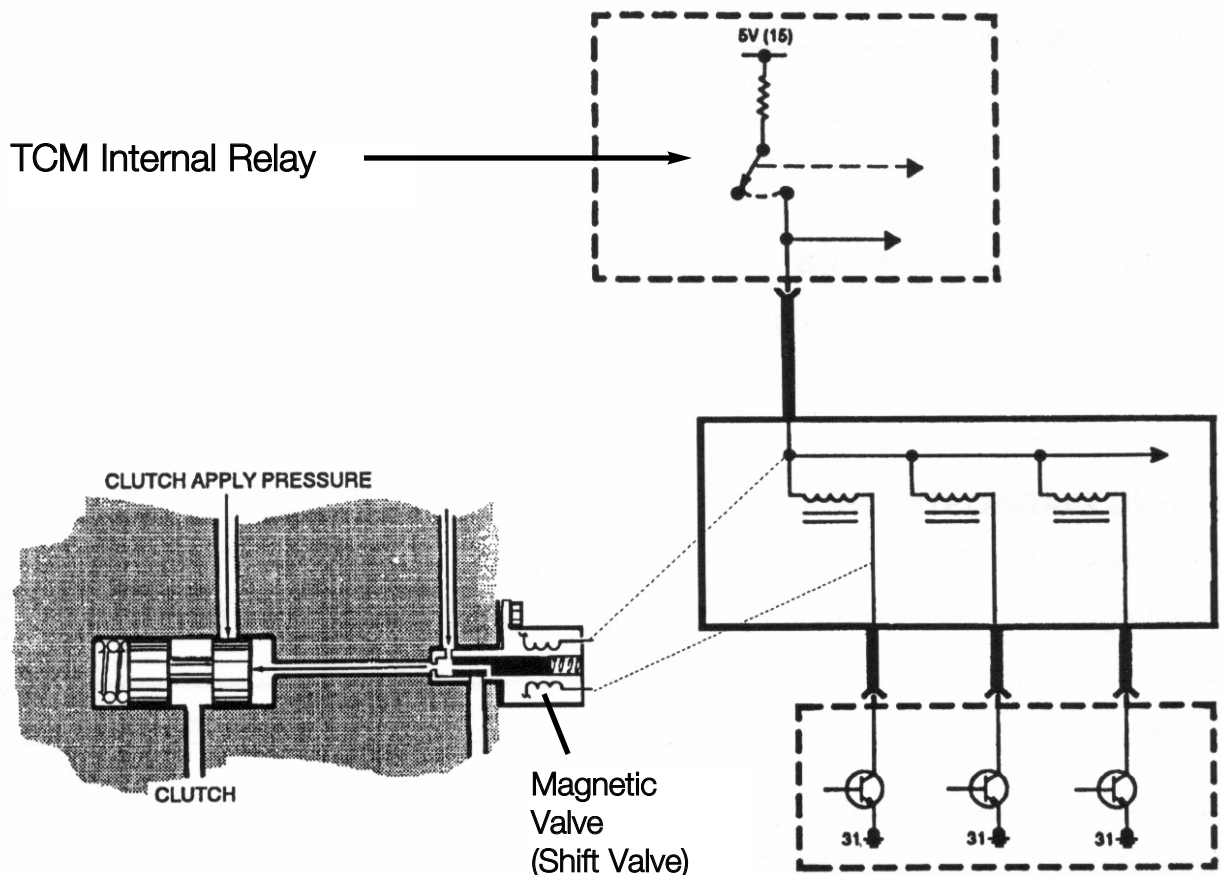

Pressure Regulation

Pressure regulating solenoids modify line pressure for hydraulic operation. Solenoids for pressure regulation are referred to as EDS valves in ZF transmissions. GM transmissions have a few terms such as Force Motor Solenoid, Variable Bleed Solenoid, and DR solenoid. Regardless of the name used, they are all used to control main line pressure based on throttle position and engine load.

On ZF transmissions, EDS valves are also used to control “Overlap Shifting”. This allows for improved shift comfort by controlling pressures during shifting.

Depending upon transmission application, pressure regulating solenoids can be controlled using Pulse Width Modulation on B+ or B-.

The TCM will increase line pressure by regulating current flow to the pressure regulator. Current flow is controlled by pulse width modulation. When the duty cycle is low, the current flow to the solenoid is low. This allows spring pressure to close the valve. Therefore maximum line pressure is achieved. As the duty cycle increases, the current flow also increases. The valve opening increases, which allows pressure to be released through the pressure discharge which in turn decreases line pressure.

Main line pressure is also increased during failsafe operation and when needed during “Adaptive Hydraulic Pressure Control” functions. Mainline pressure will also default to maximum pressure when power to the TCM is switched off.

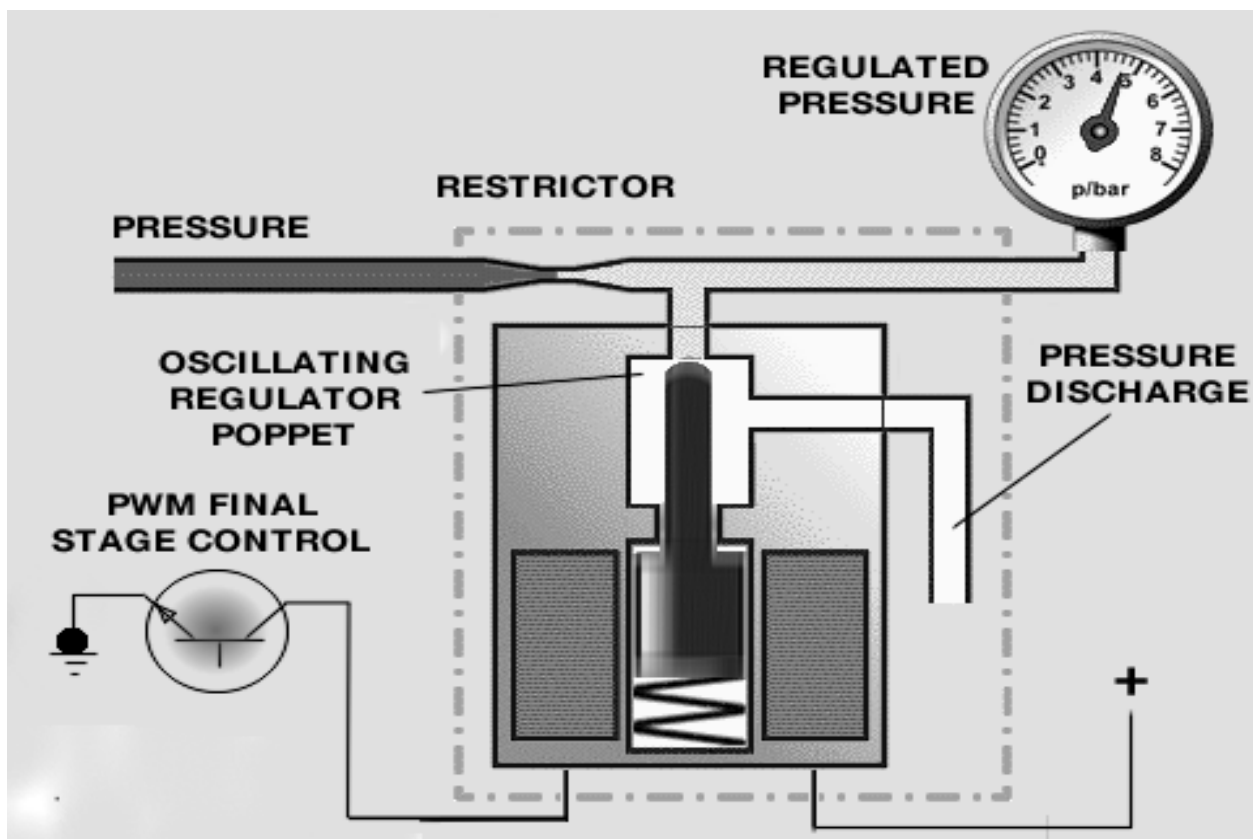

Shift Programs

BMW EH transmissions have selectable shift programs (or modes) to suit driver needs and operating conditions. There are 3 basic shift programs available:

- **Economy Program** - The economy program is the default program which is adopted every time the vehicle is started. When in economy mode, the operating priority is for maximum economy and shift comfort. Shifts will take place at low engine RPM and road speed. The economy mode is indicated by an “A” on the program switch. The cluster will display an “E” to indicate economy mode.
- **Manual Mode (Winter Mode)** - Manual mode is used to start out the vehicle in a higher gear on slippery surfaces when more traction is needed. A higher gear will reduce torque to the rear wheels. Manual mode can also be used to select a lower gear when needed such as when climbing a hill. Depending upon vehicle application an “M” will appear in the cluster when in Manual Mode or an asterisk (*) symbol will appear in the instrument cluster to indicate Winter Mode.
- **Sport Mode** - Sport Mode provides raised shift points and a more aggressive shift program for the “Enthusiastic” BMW driver. The cluster will display an “S” when in sport mode.

Regardless of vehicle application, the program switch provides a momentary ground to the TCM to switch between modes. There have been numerous designs of the program switch since its introduction. The program switch configurations are as follows:

- **2 Position Slide Switch** - This switch has the “A” and the “M” selection. Sport mode is achieved by moving the selector lever from “D” to 4, 3 or 2 when in the Economy Mode. The 2 Position slide switch is used on most models. These vehicles usually have a range and program display located in the instrument cluster.
- **2 Position Rocker Switch** - This switch operates the same as the slide switch, but it is used exclusively on the E36. The E36 does not have a program indicator in the cluster. The rocker switch will illuminate, indicating the current program.
- **3 Position Slide Switch** - This switch has the added position for sport mode. The shifter does not have to be moved out of drive (D) to be in sport mode. This switch is used on the E36 M3 and the 4HP22/24 EH (Version Late E-7).
- **3 Position Rotary Switch** - This switch is used only on the Early 4HP22 EH transmissions (Version Early E-7).
- **No Program Switch** - On some vehicles with AGS features, there is no program switch. Shift modes are obtained by moving the shift lever out of “D” range or automatically by adaptive shift functions. (Example E39)

3 Position Program Switch

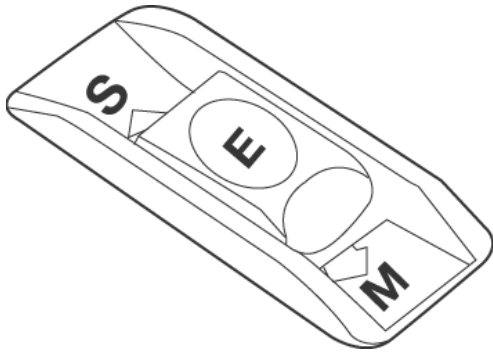

E38
Selector Lever
and Program
Switch
(2 Position)

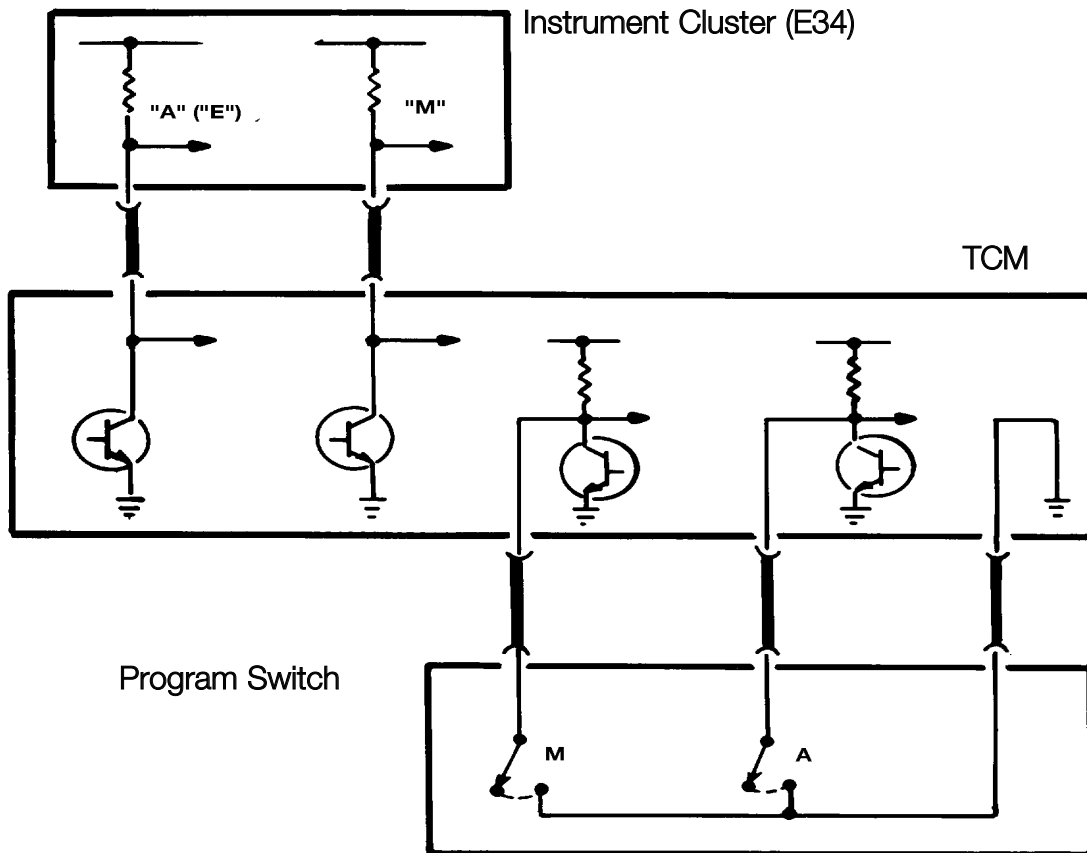
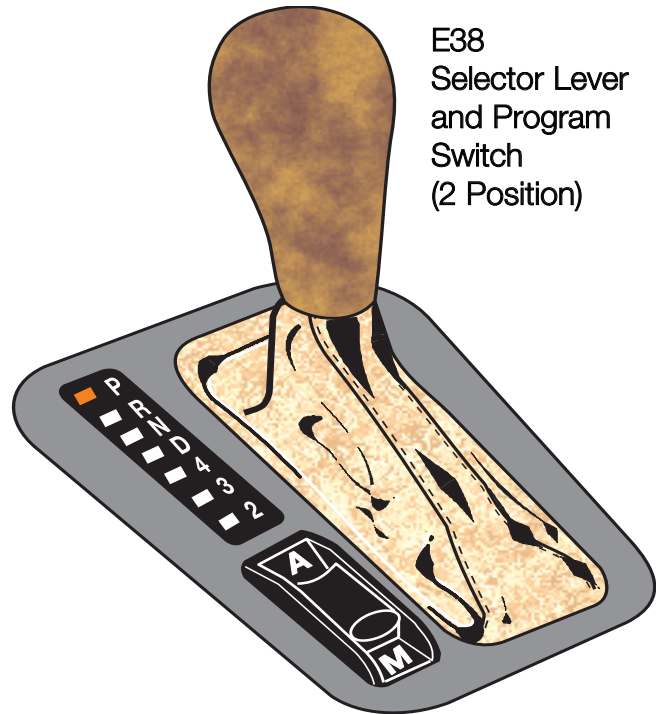

Steptronic Shift Modes

The Steptronic shifting system was introduced to the BMW model line on the 95 E31 850Ci (from 10/94). Steptronic was subsequently added to other BMW models and is available on all BMW models with automatic transmissions. Other than a few additional components in the shifter mechanism, Steptronic equipped vehicles use the same transmission and TCM as non-Steptronic equipped vehicles.

Since the introduction of Steptronic, there have been several variations in Steptronic function. Regardless of version, the Steptronic system provides the driver with two modes of operation:

- To operate the transmission in fully automatic mode as with a non-Steptronic transmission.
- To operate the transmission in the manual shift mode by tilting the shift lever forward or backward when in the manual gate.

The Steptronic shift lever console contains an automatic and a manual shift gate. The automatic gate contains the gear lever positions P/R/N/D. When the lever is placed in “D” all of the shifting takes place based on the shift map programming in the TCM. To enter the manual gate the shift lever is moved 15 degrees to the left. Depending upon application, there are three possible configurations of the manual gate:

- On the E31 850Ci, the gate is marked as “M” only. There is a plus and minus sign for manual shifting. Upshifts are achieved by momentarily moving the shifter forward. Downshifts are achieved by moving the shifter rearward. When placing the shifter into the “M” gate, the transmission will adopt the current gear that is engaged. The transmission will stay in that gear until an upshift or down shift request is made.
- On all other vehicles until the 2002 model year, the gate is marked M/S. There is also a plus and minus sign for manual shifting. When placing the shifter into the M/S gate, the transmission will adopt Sport mode. All shifts will still be automatic. Full manual mode is achieved when an upshift or downshift request is made. Upshifts are achieved by moving the shifter forward momentarily and downshifts are achieved by moving the shifter rearward.
- On all models with Steptronic from 2002, the only change is to the manual shifting modes. In order to be consistent with SMG operation, the positions were reversed. Upshifts are now achieved by moving the shifter rearward and downshifts are now forward. Otherwise, Steptronic operation is identical to the previous models.

Automatic Functions in Manual Mode

When in manual mode there are certain functions which occur automatically to prevent drivetrain damage and improve driveability:

- **Engine Overspeed Prevention:** To prevent engine over-rev, the TCM will upshift automatically just prior to max engine cutoff.
- **Kickdown:** If plausible, the TCM will automatically shift down to the next lower when a kickdown request is received.
- **Decelerating:** If in 5th gear and coasting to a stop, the TCM will automatically down shift to 4th gear at approximately 31 mph and then 3rd gear at approximately 19 mph. The automatic downshift allows for an acceptable gear when re-accelerating. (6 cylinder models will shift to 2nd gear when stopping vehicle)
- **Implausible Gear Requests:** Certain shift requests are ignored by the TCM. For example, requesting a downshift at a high rate of speed would be ignored. Any shift request that would cause the engine to exceed the maximum RPM limit would not be allowed. Also starting out in a high gear is also not allowed. Only 1st, 2nd or third gear is allowed when accelerating from a stop.

**E31 850Ci
Shifter Console**

1995 to 1997 Model Year.

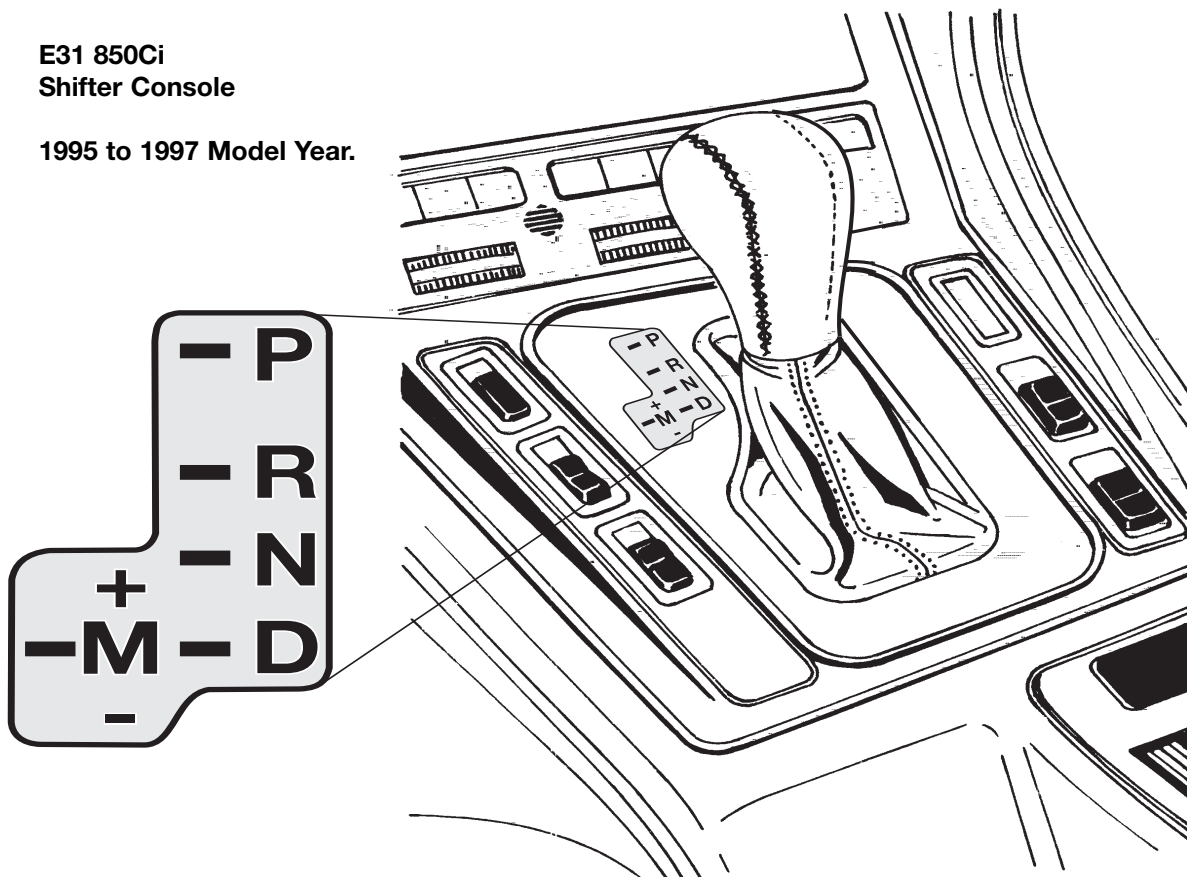

Steptronic Shifter Circuit

In order to achieve manual shifts with Steptronic, the selector lever is moved 15 degrees to the left. A pin on the selector lever engages the "up/down" microswitches which are a ground input to the TCM. The selector lever also triggers the "M" gate microswitch which is also a ground input to the TCM.

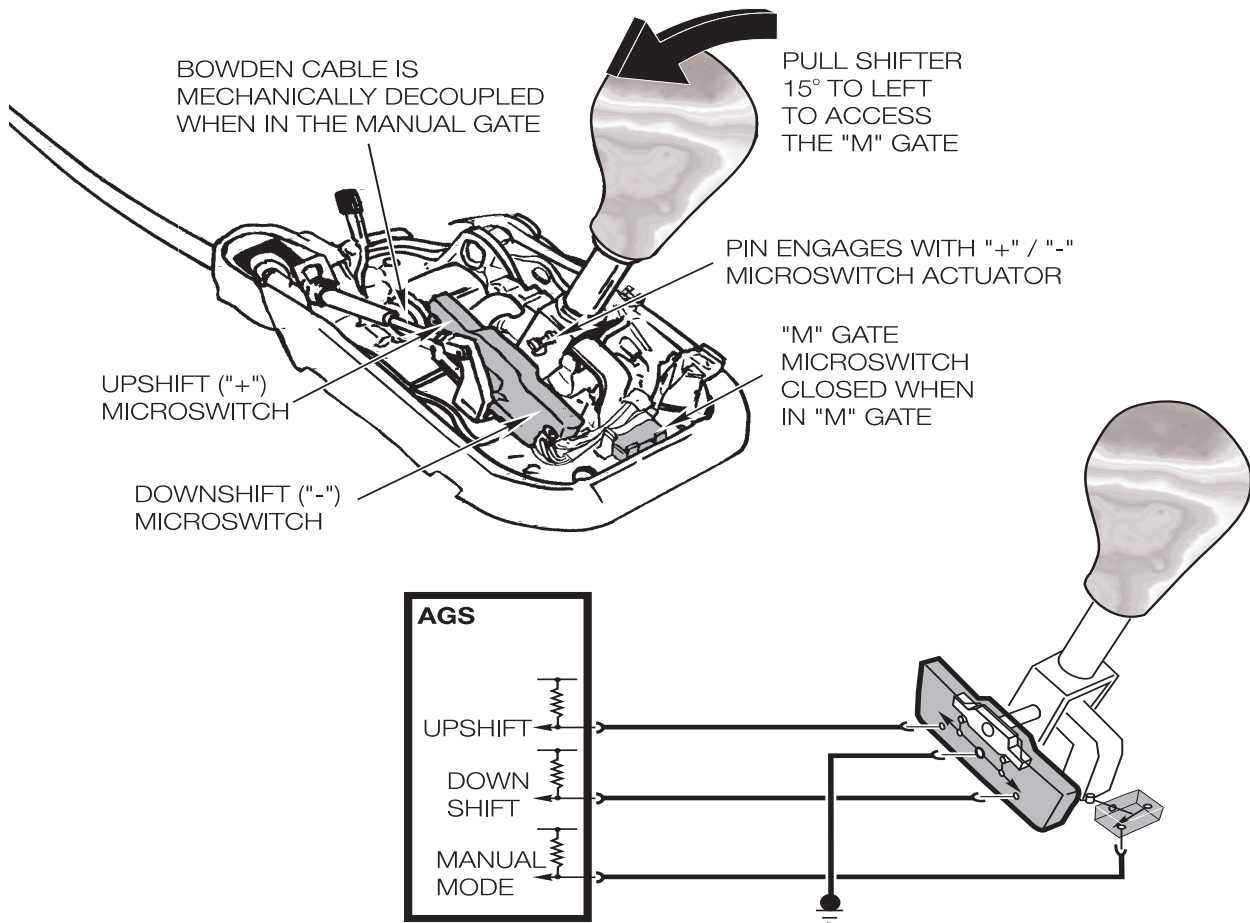

The example on the right shows a typical shift console for an E31. Note the shift pattern, upshifts are forward and downshifts are rearward. This shift pattern was used on vehicles up to the end of 2001 production. On vehicles from 2002 production, the shift pattern is reversed.

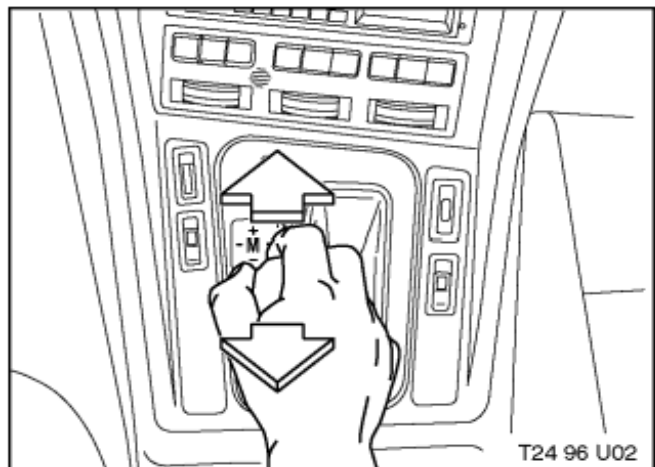

Steptronic System Comparison

| Detail | E31 850Ci 1995 to 1997 | All model except E31 850Ci up to 2001 Model year with Steptronic. | All Models from 2002 model year with Steptronic |
|------------------------------------|--|--|--|
| Shift Console Layout | "M" Gate | M/S Gate | M/S Gate |
| Selection of Manual Mode | Shift to "M" gate | Shift to "M/S" gate and move lever momentarily to "+" or to "-". | Shift to "M/S" gate and move lever momentarily to "+" or to "-". |
| Gear Range in Manual Mode. | 2nd to 5th gear (1st gear only accepted for 2 minutes after cold start. If the throttle is pressed 100% a 2-1 shift will occur | 1st to 5th gears | 1st to 5th gears |
| Un-allowable gear requests. | 4th and 5th gear after vehicle standstill. Downshifts that can cause engine over-rev. 1st gear after engine warm up. | 4th and 5th gear after vehicle standstill. Downshifts that can cause engine over-rev. | 4th and 5th gear after vehicle standstill. Downshifts that can cause engine over-rev. |
| Upshifts/Downshifts | Upshifts - Forward Downshifts - Rear | Upshifts - Forward Downshifts - Rear | Upshifts - Rear Downshifts - Forward |

Shift Pattern up to 2001

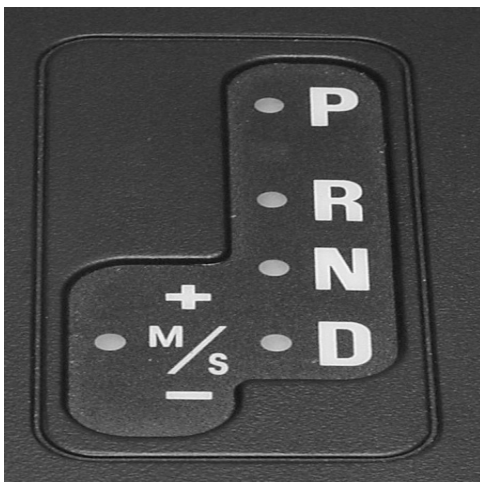

Shift Pattern from 2002

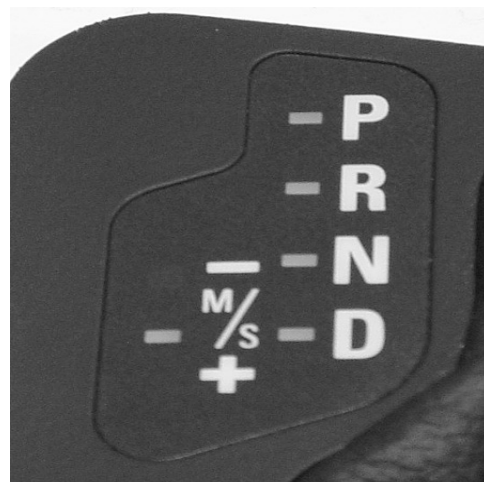

Adaptive Features (AGS)

AGS features were introduced in 1994 with the A5S560Z transmission. AGS control consists of adaptive features that will modify transmission operation according to various factors. AGS operation can be influenced by two major functional groups:

- Driver influenced features (influenced by throttle and kickdown input)
- Environmental influences (such as road conditions - icy, traffic etc.)

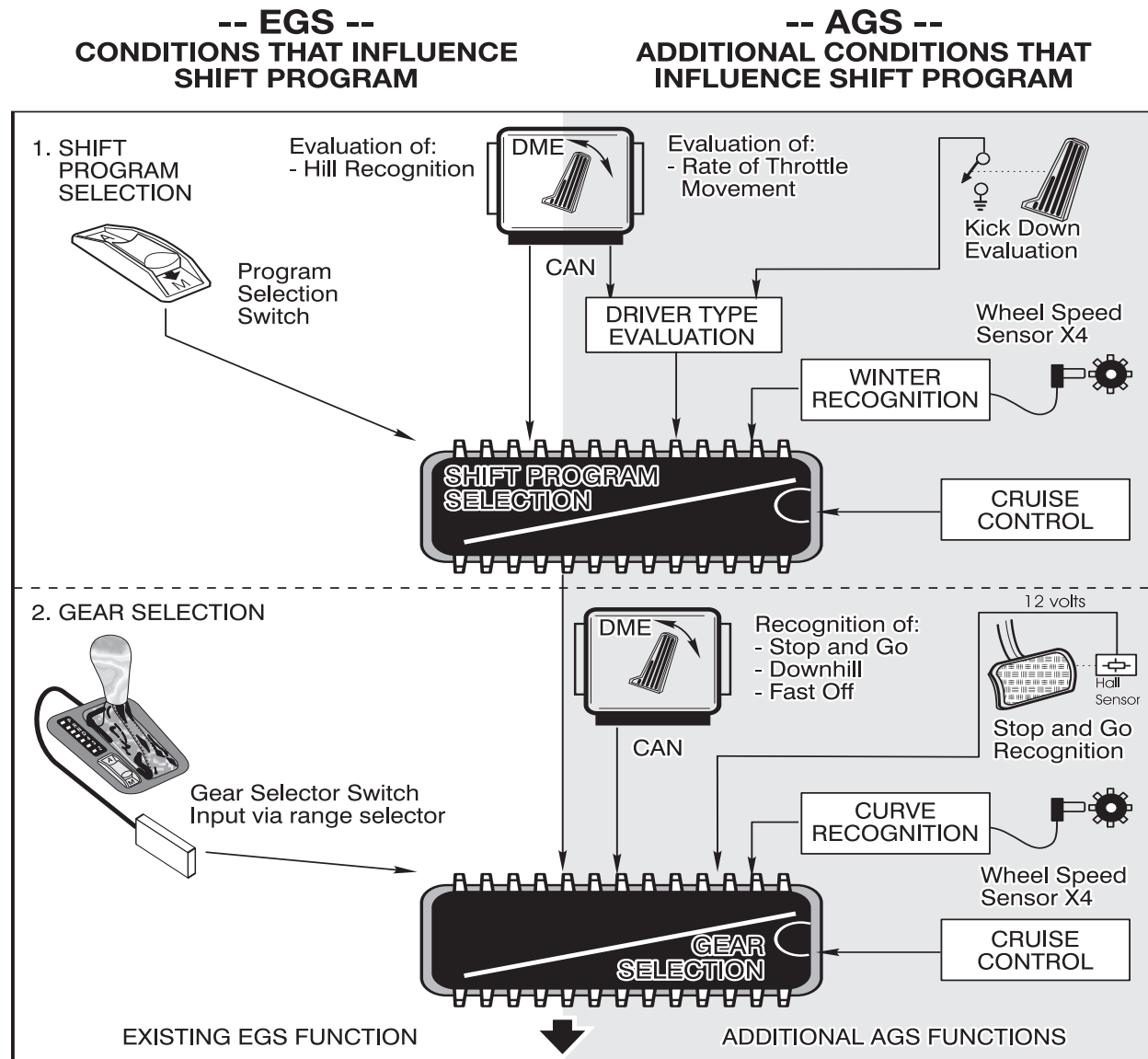

The driving program selection is not adapted on a long term basis - nor is it stored in the control module memory when the ignition is switched off. It continually changes as the driver of the vehicle changes driving habits.

Driver influenced features of AGS

The adaptive drive program is based primarily on throttle input. The throttle information comes from the ECM (DME) via the CAN bus. The TCM continuously monitors the throttle input for:

- The current throttle position
- The rate of change in pedal movement
- The number of acceleration requests
- The number of kickdown requests

Drive away Evaluation

The AGS system selects the appropriate shift program based on the amount of acceleration that occurs during takeoff. When driving away under full throttle the transmission will shift from XE to E.

Kick Fast Feature

Based on these inputs, the AGS will select one three different driving programs as follows:

- Extreme Economy - Shift points are a low speeds for maximum comfort and economy
- Economy - The shift points are raised for more performance with economy as priority
- Sport - The shift points are higher to take advantage of full engine performance.

Under full throttle acceleration at high speed, single gear downshifts are possible. A two gear downshift is possible if the accelerator pedal is moved quickly to kick-down. The Extreme Sport program was eliminated as part of the kick-fast feature.

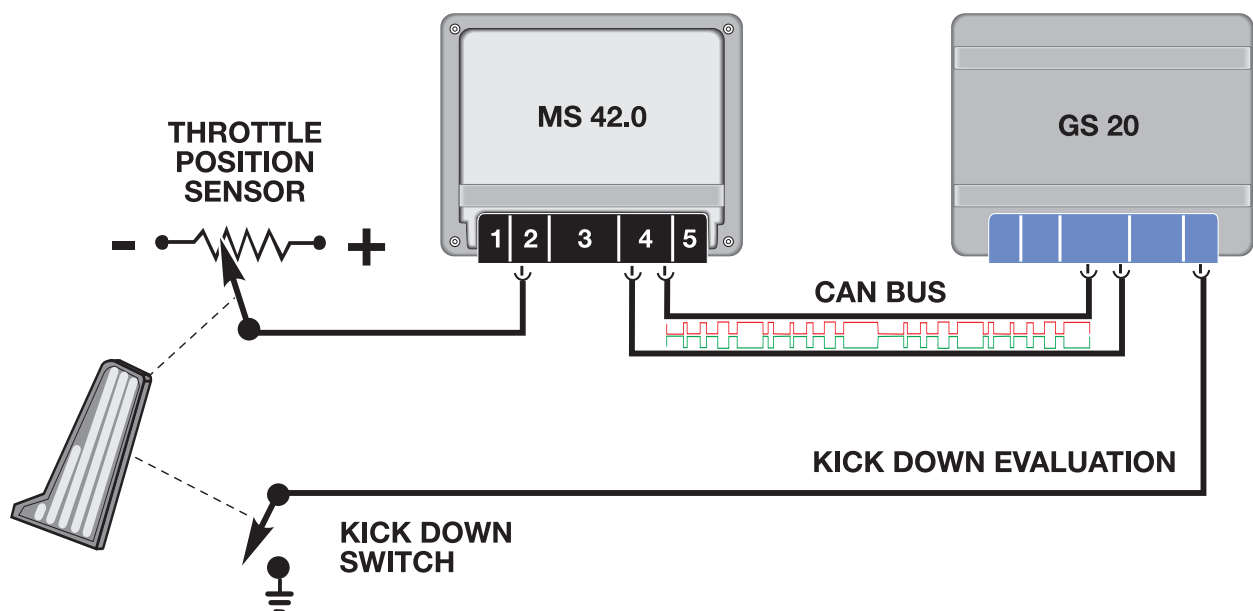

Environmentally influenced AGS features

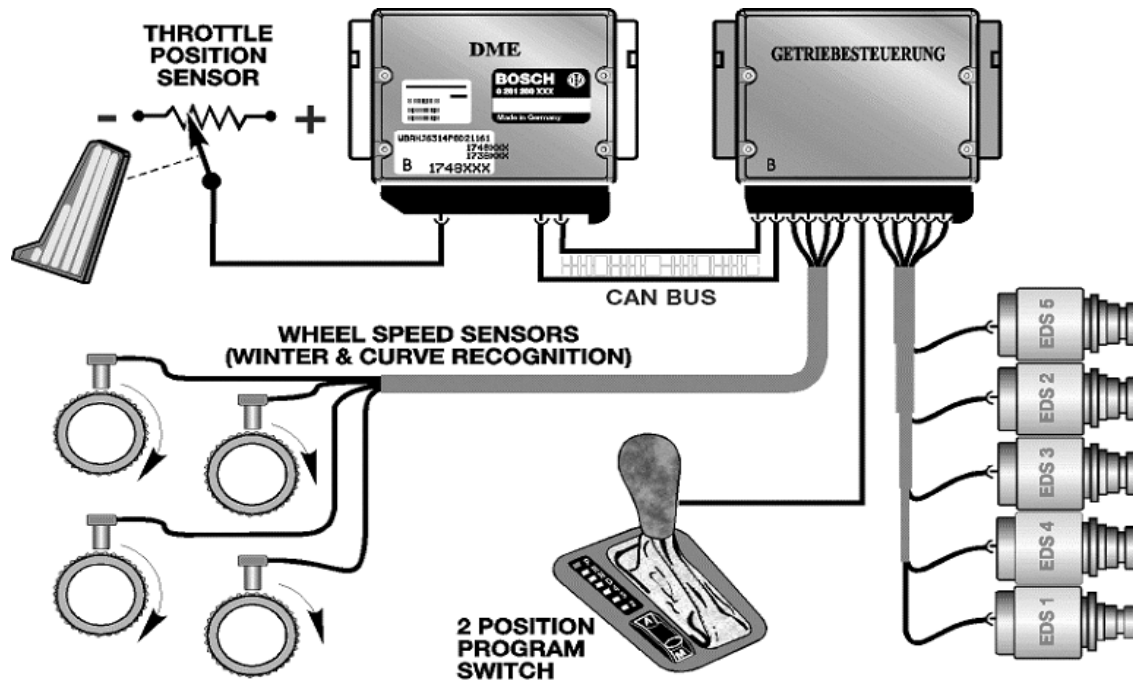

STOP and GO

The feature is activated by defined sequence of shifts which are as follows:

- Upshift from first to second - followed by a downshift from second to first - followed by another upshift from first to second. This is then followed by the vehicle coming to a complete stop.

After this sequence occurs, the transmission will stay in second gear. The AGS control has recognized stop and go driving and this function will prevent excessive shifting during heavy conditions. The second gear start will be cancelled when:

- The vehicle speed exceeds 40 MPH
- The throttle pedal is pressed more than 90%
- The range selector is moved to Park, Neutral, Reverse or Sport (4,3 or 2)
- The vehicle is in Sport Mode

Winter Drive Program

This feature is activated when the TCM detects slippage at the rear wheels by comparing front and rear wheel speed signals. When slippage is detected by the TCM, the transmission will start in second gear and the shift points will be lowered. This will reduce torque to the rear wheels allowing improved driveability and traction on slippery roads.

Hill Recognition Program

There are two hill recognition programs, one for Uphill and one for Downhill. The TCM will activate this feature when it receives a high engine load signal at slower road speeds. The TCM will perceive this information as being consistent with climbing a hill. The shift points will be raised to prevent constant up and down shifting. This is referred to as the pendulum shift effect. When driving downhill, road speed will increase with minimal throttle input. The TCM will detect a downhill situation and hold the current gear to prevent an upshift when going downhill.

Curve Recognition

This feature will inhibit upshifts when the vehicle is in a curve. This is to improve stability when the vehicle is cornering at high speeds. The TCM will initiate this feature when it detects a difference between left and right (front) wheel speed signals. The difference in these signals will indicate that the vehicle is in a curve. Be aware that improper tire sizes, brands and inflation pressures can influence this feature. Always address these issues first when diagnosing delayed upshift complaints.

Cruise Control Drive program

A special cruise control shift map is selected by the TCM when cruise control is active. The TCM will prevent unwanted locking and unlocking of the torque converter clutch. Also, upshifting and downshifting will be minimized. Depending upon application, the cruise control interfaces with TCM via a single wire data link or as on vehicles with electronic throttle control, the TCM will interface with the ECM (DME).

Manually Selected “Extreme Sport” Program

This feature is activated by moving the shift lever to position 4, 3 or 2. This activates the “Extreme Sport Program” where the shift points are raised for maximum rpm and performance. On Steptronic equipped vehicles, the sport program is obtained by moving the shifter to the manual gate to initiate the “Sport Program”.

Modifications to AGS features

Since the introduction of AGS features in 1994, there have been some software changes to address customer concerns. Some AGS features have been perceived by the customer as malfunctions. To correct this, some of the AGS features were modified with updated software. The AGS features previously discussed in this text reflect the updated modifications. Always refer to the latest Service Information Bulletins for more information on AGS features.

CAN Bus Communication

The CAN bus is a serial communications bus in which all connected control units can send as well as receive information. Data over the CAN bus operates at a rate of up to 1Mb/s (megabits per second).

The CAN protocol was developed by Intel and Bosch in 1988 for use in the automotive industry to provide a standardized, reliable and cost-effective communications bus to combat the increasing size of wiring harnesses.

The CAN bus was originally introduced on BMW automobiles in the 1993 E32 740i/IL as a data link between the TCM (EGS) and the ECM (DME).

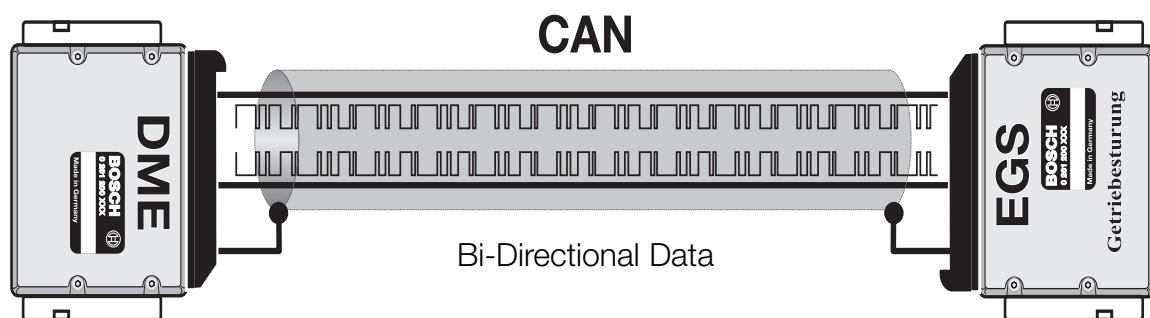

On earlier EGS systems, various signals were transmitted on individual signal wires. This reduced reliability and increased the amount of wiring needed. The CAN bus allows faster signal transmission and increased versatility. For example, the signals listed in the chart below were previously transmitted on individual wires, now these signals are all on the CAN bus. This chart represents only some of the signals on the CAN bus, there are many more signals transmitted between the TCM and ECM.

| Sender | Information Item | Receiver | Signal Use |
|--------|------------------------------|----------|---|
| ECM | Engine Temperature | TCM | Shift Point Calculation |
| ECM | Engine Load (tL) | TCM | Shift Point Calculation |
| ECM | Engine RPM (TD) | TCM | TCC Slippage |
| ECM | Throttle Position (DKV) | TCM | Shift Point Calculation |
| ECM | A/C Compressor ON | TCM | Fine tune shift points to compensate for increased engine load. |
| TCM | Transmission Range | ECM | Engine Idle Speed Control |
| TCM | Torque Reduction Signal (ME) | ECM | Timing Retard during shifts. |
| TCM | TCC Lockup Status | ECM | Engine Timing Map adjustment. |

CAN Bus Topology

The CAN bus consists of two twisted copper wires. Each wire contains an opposing signal with the exact same information (CAN-High, CAN-Low). The opposing signals transmitted through the twisted wire serve to suppress any electrical interference. Early CAN bus wiring included a grounded shield around the two wires, later vehicles discarded the shield in favor of the unshielded twisted pair wiring.

Due to the linear structure of the network, the CAN bus is available for other modules in the event of a disconnected or failed control unit. This is referred to as a “Tree” structure with each control unit occupying a branch.

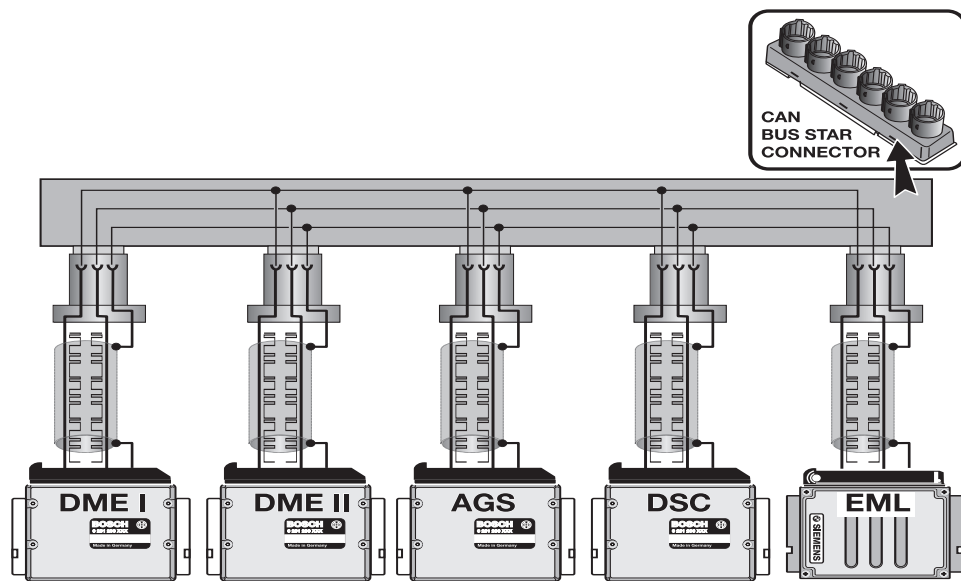

As previously mentioned, the CAN bus initially was used as a high speed communication link between the DME and AGS control units.

With the introduction of the E38 750iL (95 M.Y.), the CAN bus was expanded to include the EML and DSC control modules. The 750iL made exclusive use of the “star coupler” to link the individual CAN bus ends to a common connector.

The 1998 model year introduced new users of the CAN bus. The instrument cluster and the steering angle sensor were linked to expand the signal sharing capabilities of the vehicle.

The 1999 750iL was the last vehicle to use the shielded cable, after which the entire CAN bus went to twisted pair wiring.

Note: Always refer to the proper ETM to determine the exact wiring configuration for a specific model.

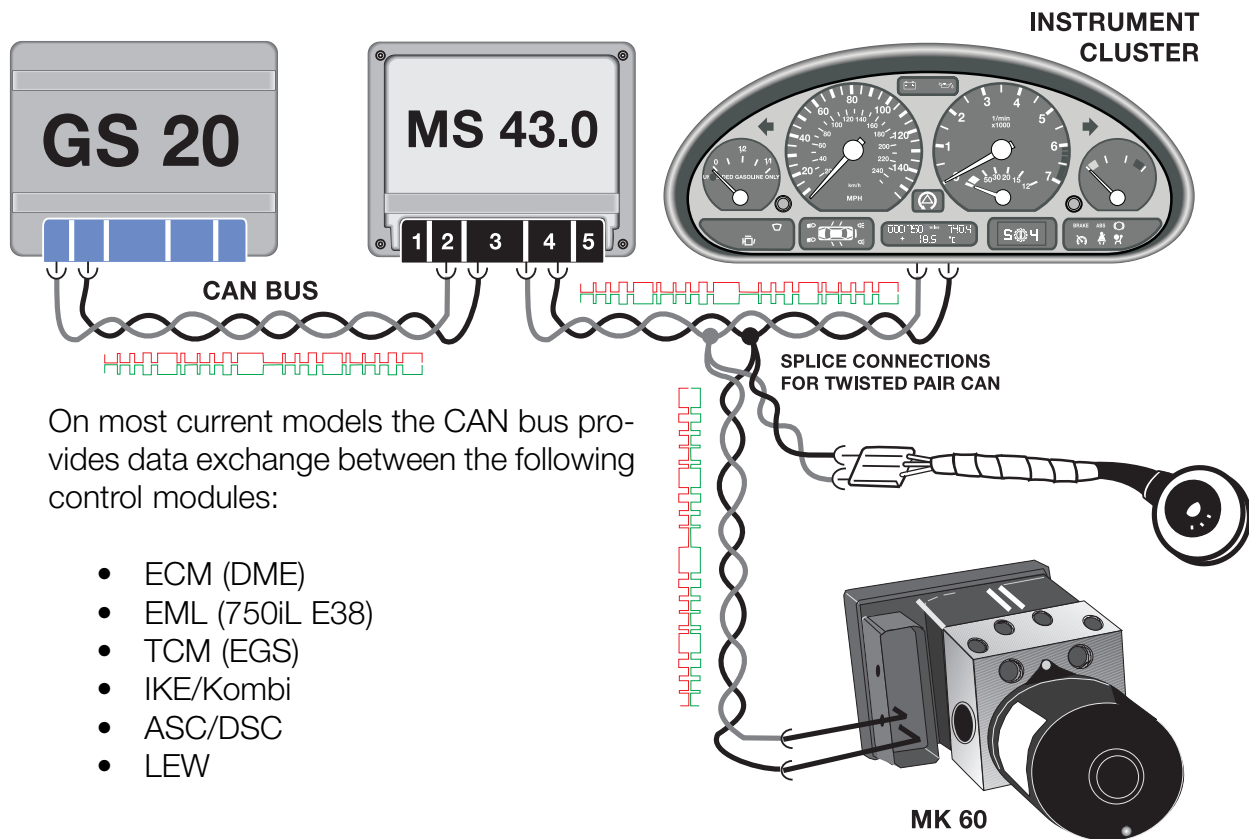

On models that use twisted pair, the wire color of the CAN bus is uniform throughout the vehicle with: CAN-Low GE/BR and CAN-High GE/SW or GE/RT. Shielded wiring is easily identified by the black sheath surrounding the CAN bus.

Troubleshooting the CAN Bus

The failure of communication on the CAN bus can be caused by several sources:

- Failure of the CAN bus cables.
- Failure of one of the control units attached to the CAN.
- Failure of the voltage supply or ground to individual modules.
- Interference in the CAN bus cables.

Failure of the CAN bus cables

The following faults can occur to the CAN bus wiring:

- CAN-H/L interrupted
- CAN-H/L shorted to battery voltage
- CAN-H/L shorted to ground
- CAN-H shorted to CAN-L
- Defective plug connections (damaged, corroded, or improperly crimped)

In each instance, the connected control units will store a fault due to the lack of information received over the CAN bus.

The voltage of the CAN bus is divided between the two data lines: CAN-High and CAN-Low for an average of 2.5V per line. The voltage measurement is taken from each data line to ground. Each module on the CAN contributes to this voltage.

The fact that 2.5V are present does not mean that the CAN bus is fault free, it just means that the voltage level is sufficient to support communication.

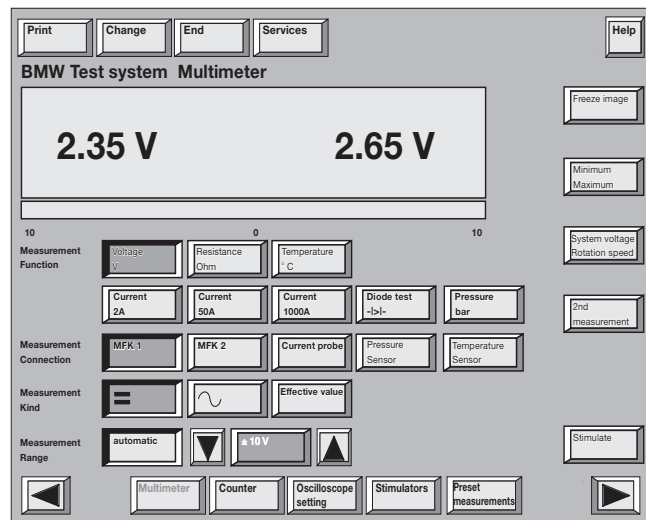

Terminal Resistors: are used in the CAN bus circuit to establish the correct impedance to ensure fault free communication. A 120 Ohm resistor is installed in **two** control units of the CAN between CAN-H and CAN-L. Because the CAN is a parallel circuit, the effective resistance of the complete circuit is 60 Ohms. On some vehicles there is a jumper wire that connects the two parallel branches together, others have an internal connection at the instrument cluster.

The resistance is measured by connecting the appropriate adapter to any of the modules on the CAN and measuring the resistance between CAN-L and CAN-H. The resistance should be 60 Ohms. The CAN bus is very stable and can continue to communicate if the resistance on the CAN bus is not completely correct; however, sporadic communication faults will occur.

The terminal resistors are located in the ASC/DSC control unit and either the instrument cluster or in the DME.

Early 750iL vehicles that used the star connector have a separate external resistor which connect CAN-H and CAN-L together.

Modules which do not have the terminal resistor can be checked by disconnecting the module and checking the resistance directly between the pins for CAN-H and CAN-L. The value at these control units should be between 10kOhms and 50kOhms.

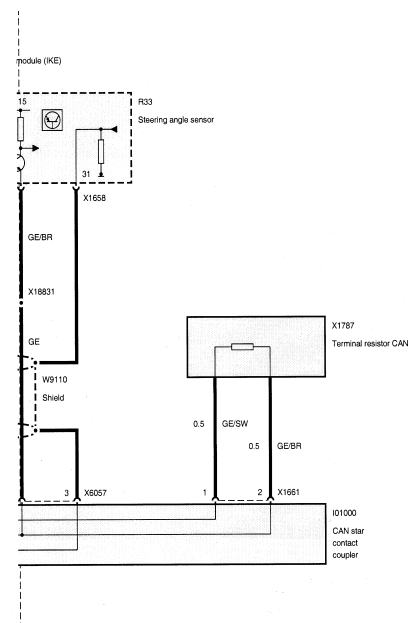

Can Bus Worksheet

Chassis #: _____ **Vehicle:** _____

Transmission: _____ **Control System:** _____

How many CAN bus resistors are there on this vehicle? _____

Where are they located? _____

Measure the resistance of the CAN bus and record here: _____

List all of the modules on the CAN bus in this vehicle: _____

What are the wire colors of the CAN bus in this vehicle?

List some information items (signals) that are received by the TCM from the ECM (DME):

List some information items (signals) that are received by the ECM from the TCM (DME):

On what BMW vehicle was the CAN bus introduced?

Notes:

TCM Coding and Programming

As with other control modules used on BMW systems, the TCM must be programmed and/or coded for the vehicle. Over the years, these methods have varied from system to system. Refer to Service Information Bulletins for the latest coding and programming information.

Coding

Coding will assign the control unit to a particular application. Information such as differential ratio, tire size, vehicle series, engine, engine control system, w/wo AC etc. are some of the possible variants that have to be considered. Transmission control units are coded using various methods.

- **Grounding pins in wiring harness connector** - On early models equipped with the 4HP22/24 EH transmissions, the TCM was coded to the vehicle by means of grounding pins in the wiring harness connector for the TCM. By selectively grounding specific pins in the harness, the TCM was assigned to that vehicle. For Example: The TCM could be installed in a 535, 635, or a 735. This only applies to the Early E-7 Versions. (E23, E24, E28)
- **TCM ordered for Specific Application** - On some later models, the TCM was ordered for a specific vehicle application, coding was not necessary.
- **Coding performed during programming** - On systems that use a flash programmable TCM, the coding process is done during flash programming.

Programming

Programming refers to the instructions that the TCM is to follow. The TCM is programmed to apply certain shift maps according to operating conditions such as vehicle speed, engine speed, engine temperature, engine load and throttle position. This information can be entered into the TCM via an updated EPROM or through flash programming.

Flash programmable control units use a EEPROM which is Electronically Erasable. The EEPROM is also soldered into the TCM and cannot be removed or replaced. Flash programmable TCM's can be programmed up to 14 times (with a new TCM).

Note: Always clear adaptations after programming.

Note: Do not program a TCM to correct a complaint unless there is a specific SIB that covers the issue. Only program when installing a new TCM or when instructed to do so by BMW Technical Assistance. Always have the ID page available when calling for technical assistance.

| Control System | Transmission | Coding | Programming | TCM Type |
|---|--|---|--|--|
| GS 1.26 GS 1.27 GS 1.29 | 4HP22 EH (Early E-7) 4HP22/24 EH (Late E-7 and E-9) | Grounding pins in Harness. (Early E-7 Only) TCM ordered for specific application. Coding not needed. | Replaceable EPROM Replaceable EPROM | 35 Pin 35 Pin |
| GS 7.3 GS 7.32 GS 7.11 GS 8.32 | A5S310Z (5HP18) | TCM ordered for specific application. Coding not needed. | Replaceable EPROM | 88 Pin |
| GS 8.60 GS 8.60.4 | A5S325Z (5HP19) | Coding done when Programmed | Flash Programming (EEPROM) | 134 Pin SKE |
| GS 8.55 GS 8.60.2 | A5S440Z (5HP24) | Coding done when programmed | Flash Programming (EEPROM) | 88 Pin up to 98 (E38 M62) 134 Pin SKE from 98 to present. |
| GS 9.2 GS 9.22 GS 9.22.1 | A5S560Z (5HP30) | TCM ordered for specific application. Coding not needed. | Replaceable EPROM | 88 Pin |
| GS 8.60.3 | A5S560Z (5HP30) (E38 M73TU) | Coding done when programmed. | Flash Programming (EEPROM) | 134 Pin |
| GS 4.14 GS 4.16 | A4S310R (THMR-1) | TCM ordered for specific application. Coding not needed. | Replaceable EPROM | 55 Pin |
| GS 8.34 | A4S270R (THMR-1) | TCM ordered for specific application. Coding not needed. | Replaceable EPROM | 88 Pin |
| GS 20 | A5S360R A5S390R | Coding done when programmed | Flash Programming (EEPROM) | 134 Pin SKE |

Transmission Fluid

Transmission Fluid Checking Procedures

Transmission fluid checking is accomplished using the DISplus or GT-1. The DISplus or GT-1 is used to monitor transmission fluid temperature to insure the transmission is not over or under-filled. As with most other current ZF transmissions there is no dipstick, the fluid level is checked and filled at the fill plug. The location of the fill plug varies between transmissions.

Transmission fluid should be checked between 30 and 50 degrees Celsius (unless otherwise specified). Use the DISplus and/or GT-1 to determine transmission temperature. The transmission temperature information can be found in the diagnosis section under Service Functions.

Proper procedures for checking and filling transmission fluid can be found in BMW Service Information Bulletin B 24 01 98.

When checking transmission fluid, observe the following items:

- Transmission in Park
- Parking brake applied
- Engine Running
- Vehicle level
- No engine load
- Trans Temp 30-50C
- Observe correct drain plug torque
- Use correct fluid

When replacing parts on transmissions that use lifetime fluid, drain fluid into a clean container and reuse.

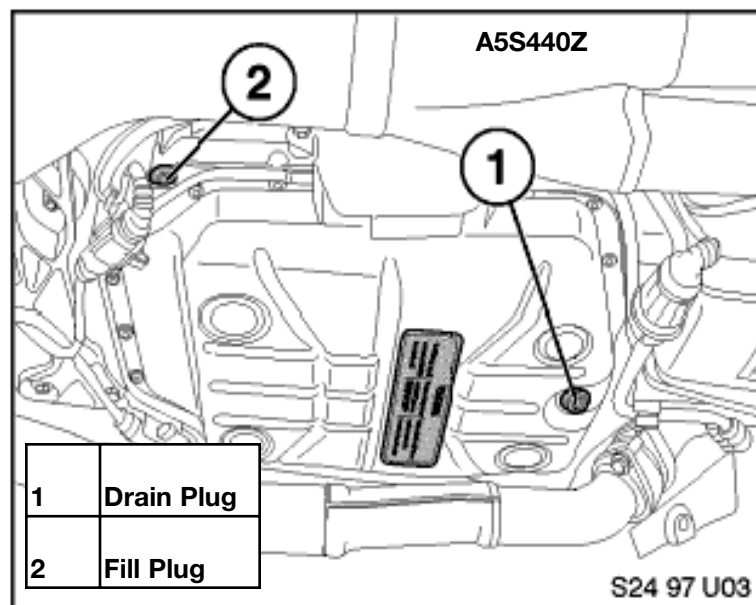
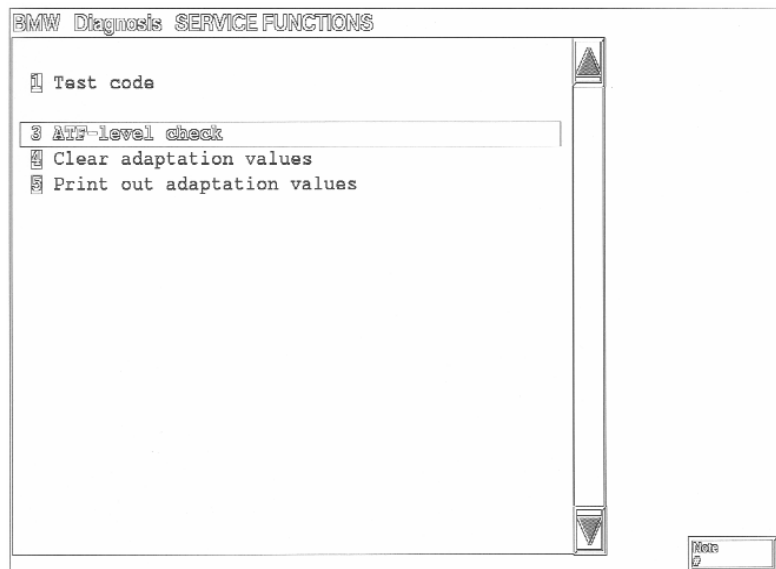

Transmission Fluid Application

There are numerous types of transmission fluid used in BMW transmissions. With the exception of the early transmissions (4HP22/24, A4S310/270R and the A5S310Z in the E34) all current BMW transmissions use “Lifetime Fill” transmission fluid. There is no maintenance required for these transmissions. It is important to use the correct fluid. Incorrect use of the transmission fluid can cause non-warrantable transmission damage.

When performing repairs on transmissions with lifetime fluid, it is important to drain the transmission fluid in to a clean container for re-use. New fluid should only be used for transmission replacement and for topping off after repairs.

Also, transmission fluid level is vital to the proper operation of the transmission. Refer to BMW Service Bulletin B 24 01 98 for proper fluid level checking procedures.

When servicing or repairing BMW automatic transmissions, refer to TIS for fluid capacities. For fluid types refer to the “Operating Fluids Manual”.

| Transmission | Fluid Type | BMW Part # | Container | SIB Ref. |
|--|----------------------|--|--------------------|------------|
| 4HP22 4HP24 | Dexron III Mercon | Available Commercially (Castrol or Texaco) | N/A | |
| A5S310Z 530i/iT (E34) | Dexron III | Available Commercially (Castrol or Texaco) | N/A | |
| M3 (E36) | ESSO LT 71141 | 83 22 9 407 807 | 20 liter container | B 24 03 95 |
| A5S325Z | ESSO LT 71141 | 83 22 9 407 807 | 20 liter container | |
| A5S440Z | ESSO LT 71141 | 83 22 9 407 807 | 20 liter container | |
| A5S560Z 740 (E32), 540 (E34) 840Ci (E31- 6/93-12/94) 740i/iL -750iL (E38) | Shell LA2634 | 83 22 9 407 765 | 5 liter container | B 24 11 92 |
| 540i (3/96-12/96) 850Ci (10/94-6/97) | ESSO LT 71141 | 83 22 9 407 807 | 20 liter container | B 24 02 94 |
| A4S310R A4S270R (THM-R1) | Dexron III Mercon | Available Commercially (Castrol or Texaco) | N/A | |
| A5S360R | Texaco ETL 7045E | 83 22 0 026 922 | 25 liter container | |
| A5S390R | Texaco ETL 8072B | 83 22 0 024 359 | 25 liter container | |
| GA6HP26Z | Shell M-1375.4 | 83 22 0 142 516 | 20 liter container | |

Transmission Fluid Checking Worksheet

Task: Completely fill in the worksheet using instructor designated vehicle.

Chassis #: _____ **Vehicle:** _____

Transmission: _____ **Control System:** _____

What transmission fluid does this transmission use? _____

What tool(s) are needed to remove/install the fluid fill plug? _____

What is the tightnening torque of the fluid fill plug? _____

What SIB refers to “Transmission Fluid Checking Procedures”? _____

Decribe the path used to find the “ATF Level Check” in the DISplus or GT-1:

What is the fluid capacity of this transmission? _____

Where can information on transmission fluid capacities be found? _____

Notes:

Transmission Service

Overview of Allowable Repairs

Currently, service of transmissions covered under warranty is limited to level I. Level I service includes electrical, minor mechanical and hydraulic repairs as well as repair manual provided service adjustments.

Part availability is limited to include the repair of the following:

- **Oil Leaks** - Radial Seals and gaskets.
- **Mechanical/Hydraulic Faults** - Torque Converter, Valve Body, parking pawl, oil pan, output shaft bearing.
- **Electrical Faults** - Solenoid Valves, pressure regulator valves, wiring harness.
- **Signal Sensing** - Turbine and Output Speed Sensors, CAN bus, Temp Sensor.

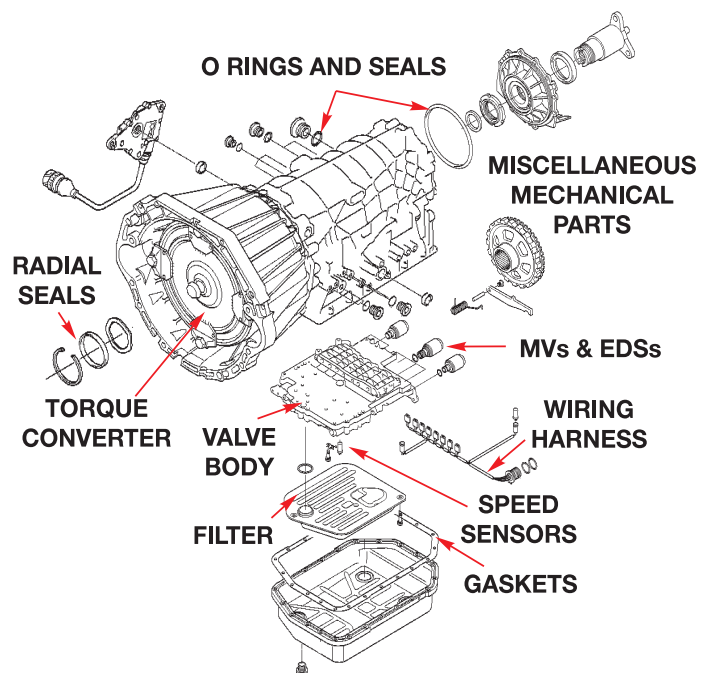

BMW Technical Hotline

Before performing any major repairs or transmission replacement, always contact the BMW Technical Hotline at 1-800-472-7222. When prompted to do so, select option 1 for the Drivetrain Group. Refer to BMW SIB B 00 04 02 for more information regarding the BMW Technical Hotline. Be prepared with all necessary information such as transmission serial number, ID page, fault codes etc. Failure to contact the technical hotline could result in the non-payment of warranty claims.

BMW Value Line Program

The Value-Line replacement transmission program provides the availability of factory certified rebuilt units at a very competitive cost. Refer to Part Bulletins in Group 24 for more information.

Diagnosis and Troubleshooting

Due to the cost and complexity of today's electronic transmissions, BMW recommends that the technical hotline be contacted before any repairs are performed. It is important that the technician perform some basic diagnostic procedures before contacting technical assistance. The following procedures should be followed:

- Always Verify customer complaint, make sure the complaint is not related to normal operation. (i.e. Warm Up Phase, AGS operation etc.)
- Survey Fault Memory - Perform **complete** quick test. There may be other systems that interface with EGS that could cause faults. (i.e DME, ASC/DSC, IKE/Kombi etc.)
- Print out all fault code with fault conditions. Also print out copy of Identification page and diagnostic report.
- CHECK TO SEE IF THERE ARE ANY SERVICE BULLETINS THAT APPLY TO YOUR SPECIFIC COMPLAINT. THIS INCLUDES THE SERVICE ROUNDTABLE.
- Ensure that battery voltage is sufficient. Battery voltage must be greater than 12.5 with ignition switched off. Check battery connections for tightness and condition.
- Check ground connections. (chassis to engine, grounds to bulkhead and shock tower.)
- Check over vehicle to look for transmission leaks, physical damage, loose connections etc.
- If necessary, check fluid level and condition using DISplus or GT-1.
- Check to see if any aftermarket or performance components have been installed that could effect transmission operation. (DME or EGS software as well as any engine modifications).
- Check repair history to see if there were any recent repairs that could effect the proper operation of the transmission (i.e. Engine replacement with damaged dowel pin etc.).
- Check DCS for any open campaigns or recalls pertaining to drivetrain.
- Check and record chassis number, production date and transmission serial # before contacting technical assistance.

Establishing a Diagnostic Plan

Once all of the pre-diagnostic criteria has been satisfied, a logical diagnostic plan should be followed. A logical, well organized diagnostic plan will help avoid improper diagnosis, unnecessary parts replacement and lost diagnostic time. A technician's goal should be to satisfy the customer by "Fixing it the first time, on time, every time". The productivity of the technician can also be improved by following a logical, common-sense approach to problem solving. The following steps are recommended to form a diagnostic plan:

- **Verify the Customer Complaint** - This step is the most important, but also the most overlooked. The focus should always be on the exact customer concern. Make sure that the customer complaint is not a misunderstanding of proper vehicle operation. This step can avoid unnecessary diagnosis and lost time. If the customer concern is not exactly identified, any subsequent repairs can not be verified as being effective. This is the most common cause of "comeback" repairs. Communication between the customer to advisor and the advisor to technician must be clear. Vague or misunderstood customer complaints are often improperly diagnosed. Also make sure that the conditions under which the concern has occurred are duplicated. For example: If the customer is complaining about a shifting concern after a cold start, then the vehicle should be road tested under those conditions.
- **Analyze the Problem** - Once the complaint has been verified, then all available resources should be used to find the "root cause" of the complaint. Start out by checking Service Information Bulletins, DCS messages, and Service Roundtable information. Use the DISplus or GT-1 to access the diagnostic program and perform Diagnostic Test Modules where applicable. Electrical Troubleshooting Manuals (ETM's) should also be used when needed.
- **Isolate the Problem** - Now, the problem can be narrowed down into the final steps of diagnosis. Using proper tools and procedures, the technician can "Isolate" by using the process of elimination and common sense. Having a working knowledge of BMW systems is helpful in this area. When applicable, use all available BMW special tools and equipment. Perform all necessary electrical checks such as Voltage Drop, resistance measurements etc.
- **Repair the Problem** - Once the concern has been correctly identified, perform all necessary repairs as per BMW guidelines. Make sure all repairs are properly documented to comply with warranty policies and procedures.
- **Verify the Repair** - Make sure the customer concern has been rectified. Road test the vehicle under the same conditions whenever possible. Failure to complete this step properly is almost a guaranteed comeback. Repeat repair attempts are costly to the BMW Center and the BMW Service Technician.

REMEMBER - Fix it the first time, On Time, Everytime.

Fault Codes

When diagnosing transmission fault codes, always print out the fault code(s) and the fault conditions. When referring to the fault code itself, be aware that there are actually 3 formats for the fault code. The fault code breakdown is as follows:

Fault Code Example:

Fault Code (050) 32 Gear Monitoring 1 (P0731)

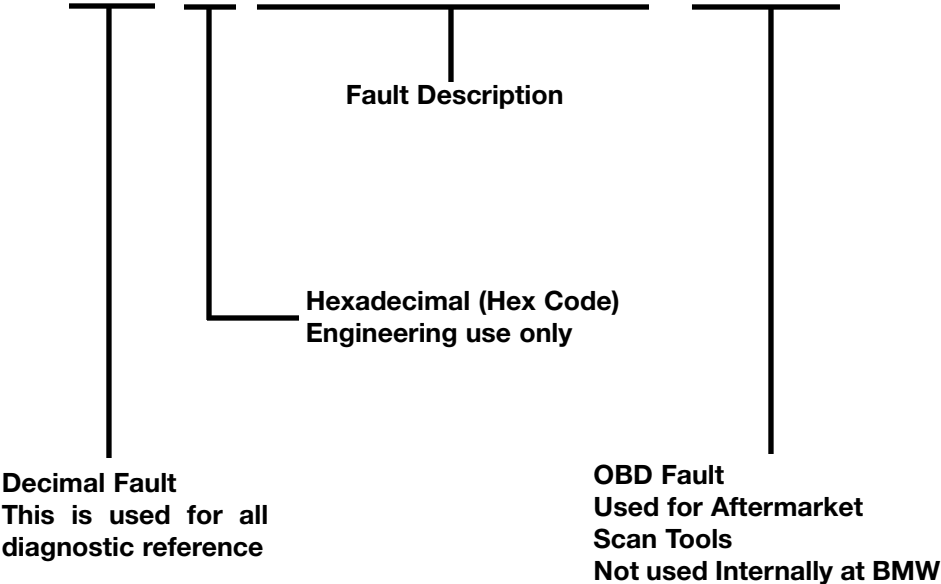

When referring to the “Fault Code” during diagnosis always use the fault that is in Decimal Format. The Decimal fault is referred to in all reference material such as Service Information Bulletins, Test Modules and DCS messages etc. In the example above, FC 050 would be the correct choice.

Fault Conditions

When a fault code is set, it is stored with a set of environmental conditions. The environmental conditions are used to aid in pinpointing the root cause of the fault. Some of the information found in the fault conditions contain information on transmission temperature, engine speed and road speed etc. This information is also helpful when trying to duplicate the customer complaint. For example, if a customer complains about a shifting complaint when cold, check the fault conditions to verify this complaint. Remember to always print out the fault codes with the fault conditions. This information is helpful to the technician as well as technical assistance.

Identification Page

The ID page is helpful to determine the Transmission and control system used as well as the chassis number and current software version. Always print out a copy of the ID page when performing any diagnosis or programming procedures.

The image shows a screenshot of a diagnostic tool window titled "BMW Diagnosis IDENTIFICATION". The window contains the following text:

```
Electronic gearbox control (EGS)
EGS 8.60.2 M62 / M57
5-speed automatic transmission A5S 440Z
(5HP-24)
Chassis Number: WBADR63452GN92270
Part number, master control module: 7512653
Programmed control unit: 7516981
Hardware number: 2B
Diagnosis index: 11
Bus index: 60
Date: 04.04. 2
Software number: 2425
Type Approval Number: 1000000
Supplier: BOSCH
```

Annotations with arrows point to specific fields:

- Control System** points to "Electronic gearbox control (EGS)".
- Trans Type** points to "5-speed automatic transmission A5S 440Z (5HP-24)".
- Chassis #** points to "Chassis Number: WBADR63452GN92270".
- TCM Part #** points to "Part number, master control module: 7512653".
- Programmed Control Unit #.** points to "Programmed control unit: 7516981".
- ZF Software #** points to "Software number: 2425".
- Manufacturer of TCM** points to "Supplier: BOSCH".

A vertical scrollbar is visible on the right side of the text area. A small "Note" icon is located in the bottom right corner of the window.

Diagnosis Program

There are two diagnostic formats (programs) used on current model BMW vehicles. The earlier diagnostic program was used on the E38 and E39. The latter diagnostic program was introduced as the “E46 Diagnostic Concept”. This is used on the E46, E65 and the E52 (Z8). The E53 X5 uses a mixture of both diagnostic programs depending upon engine/transmission options. Below is an example of the earlier diagnostic program.

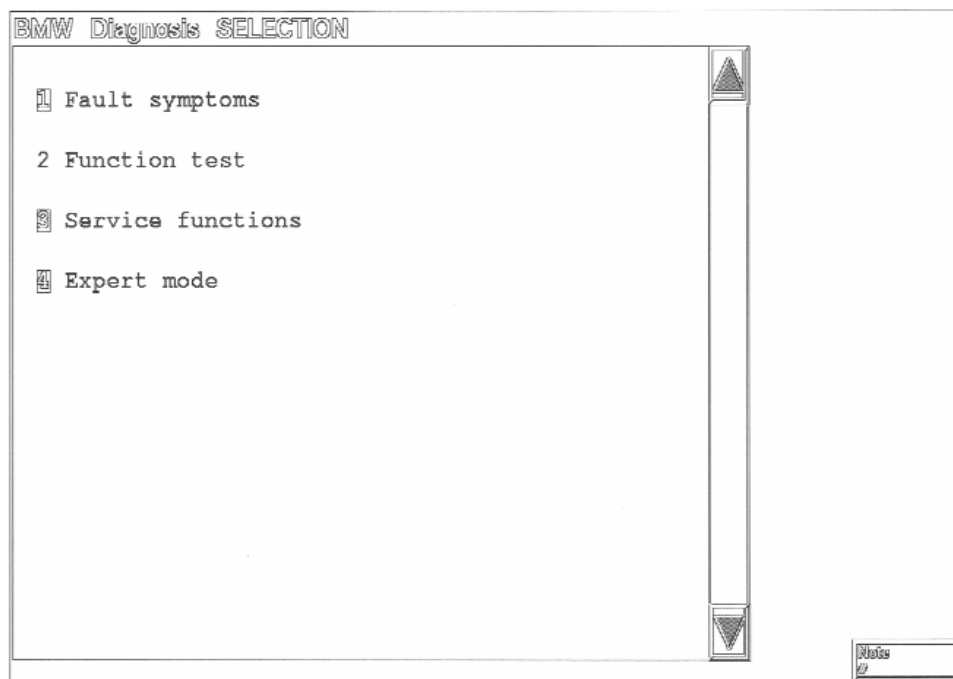

The diagnostic program contains the following features:

- **Fault Symptoms** - This is a symptom driven program that will lead the technician into guided diagnostics. It contains several possible fault scenarios that are common to electronic transmissions. This path is helpful when the technician is not sure where to start in his diagnostic plan.
- **Function Test** - There are no function tests for electronic transmissions.
- **Service Functions** - This is where you will find the ATF level check function. Also Test Codes can be obtained and printed out for warranty purposes. The Adaptation values can be cleared as well as printed out.
- **Expert Mode** - Expert Mode should be used when the technician has a thorough working knowledge of the system. You will find several items in expert mode: Read/Clear fault memory, Diagnosis (Status) requests, Component Activation and Test Modules.

Test Modules

Test modules are found in the diagnosis program of the DISplus and GT-1. These allow the technician to take advantage of a guided diagnostic plan. The program will direct the technician through the various steps using a “trouble tree” format. When using test modules it is important to follow the instructions exactly. Due to the complex nature of some faults, the test modules are not always conclusive. The test module is only as effective as the information provided by the technician. The technician also needs to rely on his experience and some common sense. The test modules should be used to assist the technician, not as a replacement for good diagnostic skills.

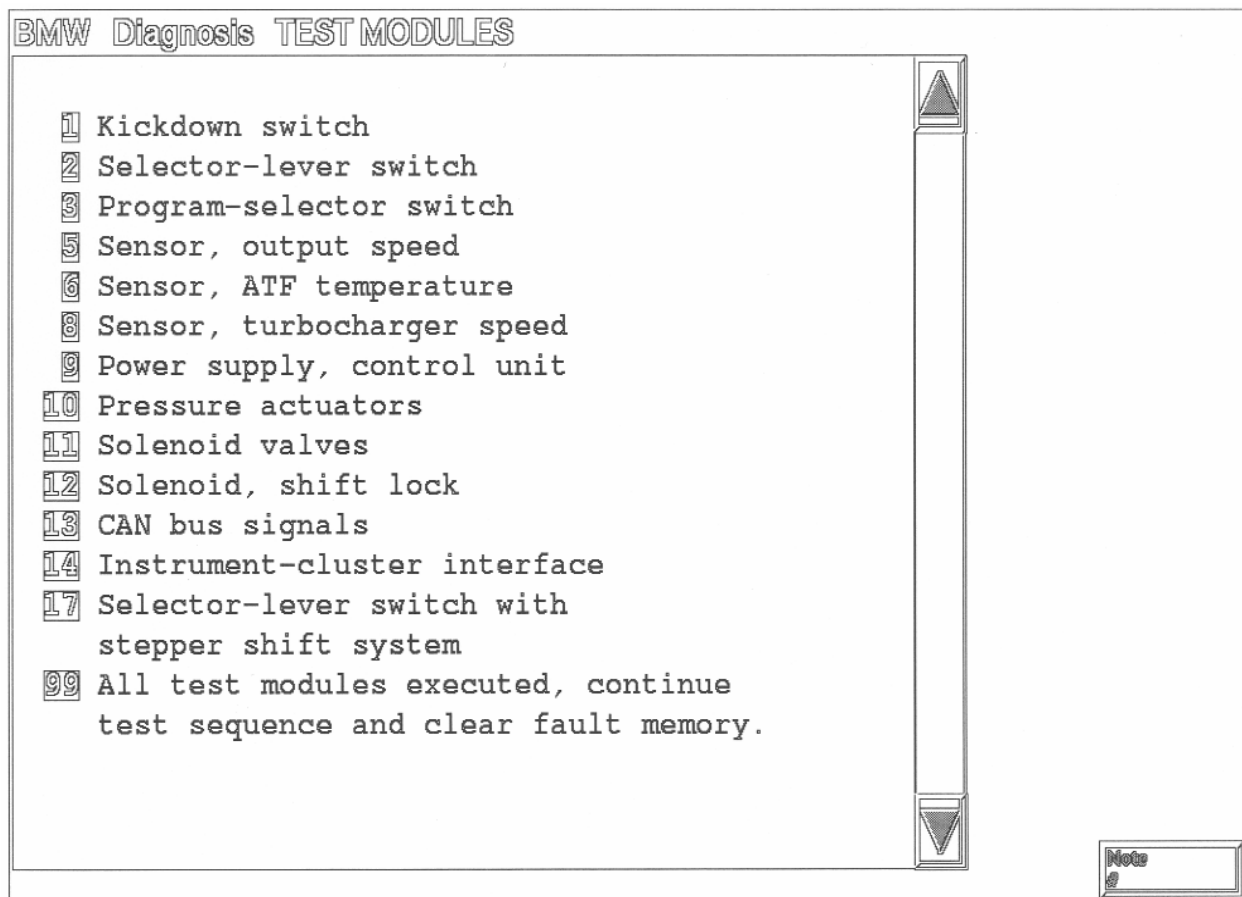

Test modules come in two formats. The one shown above is used on E38/E39 vehicles and the E53 with 4.4 and 4.6 engines. The E46, E65 and E53 (with 3.0 M54) uses the new “E46 Diagnostic Concept” which was introduced with the E46 in the 1999 model year. Regardless of the format used, the technician is still guided through a step by step procedure.

Diagnostic Tips

The following consists of some helpful hints to assist the BMW diagnostic technician. It is designed to assist the technician to form a logical path of diagnosis. These suggestions should be used in conjunction with other approved diagnostic routines. This does not exclude the technician from the responsibility to contact technical assistance. All major repairs and transmission replacement must be pre-approved by the BMW Technical Hotline. Transmission concerns can be broken down into several categories:

- **Shift Quality Complaints** - Shift Quality complaints consist of harsh up or down shifts, improper shift points and erratic shifting. These complaints could be related to electronic/software issues or hydraulic/mechanical problems. Perform quick test and check SIB's before proceeding. As with most concerns, check the transmission fluid level and condition as well.
Do not clear adaptation values unless instructed to do so by BMW Technical Hotline.
- **Delayed/No Upshifts** - Before proceeding on delayed upshift complaints, make sure you are aware of the conditions that this occurs. This could be normal operation, such as the "Warm-up Phase" program. Always check front tires for proper inflation pressures, correct size and type. Also check for uneven tire wear. Variations in front tire size from left to right can activate the AGS "Curve Recognition" feature. The TCM will interpret the difference in wheel speed signals as being a turn and suppress (or delay) upshifts.
- **Slipping** - This type of issue is usually associated with a fault code. Be sure to check the transmission fluid level and condition.
- **Noise, Vibration** - Noises and vibrations should be checked over by a good visual inspection. Look for loose transmission or engine mounts. Check the driveshaft, center bearing and flexible couplings (or constant velocity joints). Also check the lateral alignment of the driveshaft. There are several SIB's pertaining to noise and vibration.
- **No Forward or Reverse Gear** - Start by checking transmission fluid level and note the fluid condition. Inspect for leaks and external transmission damage.
- **Leaks** - When investigation transmission leaks, be sure to verify that the suspected leak is actually transmission fluid. Engine oil, hydraulic and brake fluid can be mistaken for a transmission leak. Check the transmission cooler lines, transmission cooler and transmission pan gasket. Try to locate the source of the leak. Do not make any major repairs until the technical hotline is contacted.
- **Fault Codes** - Perform COMPLETE short test (Quick test) on all vehicle systems. It is important to survey all systems in the event that a related system is causing the transmission fault. Always print out the ID Page, Fault codes and fault conditions.

Information Resources

When diagnosing transmission related concerns it is important to use all information resources available. The following information sources should be utilized at all times:

- Service Information Bulletins
- Technical Data
- ETM Electrical Troubleshooting Manual
- DCS (Dealer Communication System)
- Repair Instructions
- Tightening Torques
- Technical Training Manuals
- Special Tool Information

Technical Information System (TIS)

Most of the above information can be accessed by using the BMW TIS CD or by logging on the the BMW TIS website through **www.bmwcenternet.com**. The BMW TIS website contains a wealth of helpful information for the technician. The information is updated on a regular basis.

Service Roundtable

In addition to the above sources of information, the technician should be up to date on the latest edition of the BMW Service Roundtable. The roundtable will cover the most recent topics and offer some hints that will assist the technician. The Service Roundtable is broadcast live on a monthly basis via the BMW Visionwerke Network. In addition to live broadcasts, the roundtable is rebroadcast on a regular schedule during the month.

Training Manuals

Training Manuals are available for the various training classes that are offered by BMW. These manuals are issued when attending the training courses and can also be obtained on the BMW TIS website. This is a good source of information to help understand system operation, this can aid in a timely diagnosis.

Diagnostic Checklist

The BMW Technical Hotline is available to authorized BMW Centers. The Hotline was established to assist the BMW Technician with difficult repairs. In order to ensure the best possible quality, it is necessary to be properly prepared when calling. Make sure that all of the necessary BASIC diagnostic procedures have been followed before calling for Technical Assistance. This will reduce unnecessary phone calls which reduce the response time and increase the effectiveness of the Technical Hotline. Please follow all of these steps before calling for help. (Refer to Service Information Bulletin B000402 for more information).

1. **Verified Complaint**
2. **Perfomed Complete Quick Test with DISplus or GT-1**
3. **Printed out all relevant fault codes with environmental conditions**
4. **Checked for all applicable Service Bulletins**
5. **Checked DCS for all open issues (Campaigns etc.)_**
6. **Accessed all other information resources (Training Manual/ SRT etc)**
7. **Checked Vehicle Repair History**
8. **Performed all basic electrical checks including grounds and B+ Voltage**
9. **Perform all relevant test modules as per the Diagnosis Program**
10. **Checked for aftermarket installations that could hinder proper operation**
11. **Inspect for physical damage, loose connections**
12. **Consulted with Shop Foreman or Lead Technician**
13. **Check and record chassis # and production date**
14. **Check and record any necessary serial numbers/ID tags etc.**
15. **Call only if the vehicle is currently at your BMW Center**

Once the above checklist is complete and your complaint is still not rectified, contact the BMW Technical Hotline. Call 1-800-472-7222, select Option 1 for Drivetrain related issues. Option 2 is for Body Electrical concerns and Option 3 is for Body and Chassis.

Diagnostic Worksheet

Vehicle: _____ **Chassis #:** _____ **Prod Date:** _____

Engine: _____ **Transmission:** _____ **Control System:** _____

Complaint: _____

Was the Complaint verified? _____

Cause/Diagnostic Procedure: _____

Correction: _____

List the Special Tools that were needed to perform above diagnosis?

Notes:

Diagnostic Worksheet

Vehicle: _____ **Chassis #:** _____ **Prod Date:** _____

Engine: _____ **Transmission:** _____ **Control System:** _____

Complaint: _____

Was the Complaint verified? _____

Cause/Diagnostic Procedure: _____

Correction: _____

List the Special Tools that were needed to perform above diagnosis?

Notes:

Diagnostic Worksheet

Vehicle: _____ **Chassis #:** _____ **Prod Date:** _____

Engine: _____ **Transmission:** _____ **Control System:** _____

Complaint: _____

Was the Complaint verified? _____

Cause/Diagnostic Procedure: _____

Correction: _____

List the Special Tools that were needed to perform above diagnosis?

Notes:

Diagnostic Worksheet

Vehicle: _____ **Chassis #:** _____ **Prod Date:** _____

Engine: _____ **Transmission:** _____ **Control System:** _____

Complaint: _____

Was the Complaint verified? _____

Cause/Diagnostic Procedure: _____

Correction: _____

List the Special Tools that were needed to perform above diagnosis?

Notes:

Diagnostic Worksheet

Vehicle: _____ **Chassis #:** _____ **Prod Date:** _____

Engine: _____ **Transmission:** _____ **Control System:** _____

Complaint: _____

Was the Complaint verified? _____

Cause/Diagnostic Procedure: _____

Correction: _____

List the Special Tools that were needed to perform above diagnosis?

Notes:

Additional Information

Speed Sensor Resistance Values

| Transmission | Turbine Speed Sensor Resistance in Ohms | Output Shaft Speed Sensor Resistance in Ohms |
|--|---|---|
| 4HP22/24 | No Turbine Speed Sensor | 325 +/- 40 @ 20° C |
| A5S310Z (5HP18) | 325 +/- 40 @ 20° C | 325 +/- 40 @ 20° C |
| A5S325Z | Hall Effect Sensor No Resistance Measurement | 325 +/- 40 @ 20° C |
| A5S440Z (5HP24) | 325 +/- 40 @ 20° C | 325 +/- 40 @ 20° C |
| A5S560Z (5HP30) | 325 +/- 40 @ 20° C | 325 +/- 40 @ 20° C |
| A5S360R A5S390R (GM5) | Nominal 405 Ohms Minimum 324 Ohms Maximum 486 Ohms Checked @ 20° C | Nominal 405 Ohms Minimum 324 Ohms Maximum 486 Ohms Checked @ 20° C |
| GA6HP26Z | Not Checked in Field, Part of Mechatronics Module. Call Technical Hotline is the event of a fault. | Not Checked in Field, Part of Mechatronics Module. Call Technical Hotline is the event of a fault. |
| A4S270R A4S310R (THMR-1) (4L30-E) | No Turbine Speed Sensor | 3000 Ohms @ 20° C |

A4S310/270R Component Identification and Ohmic Values

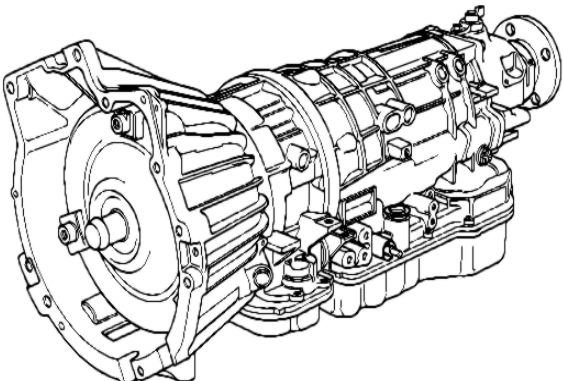

A4S270/310R (4L30-E) (THMR-1)

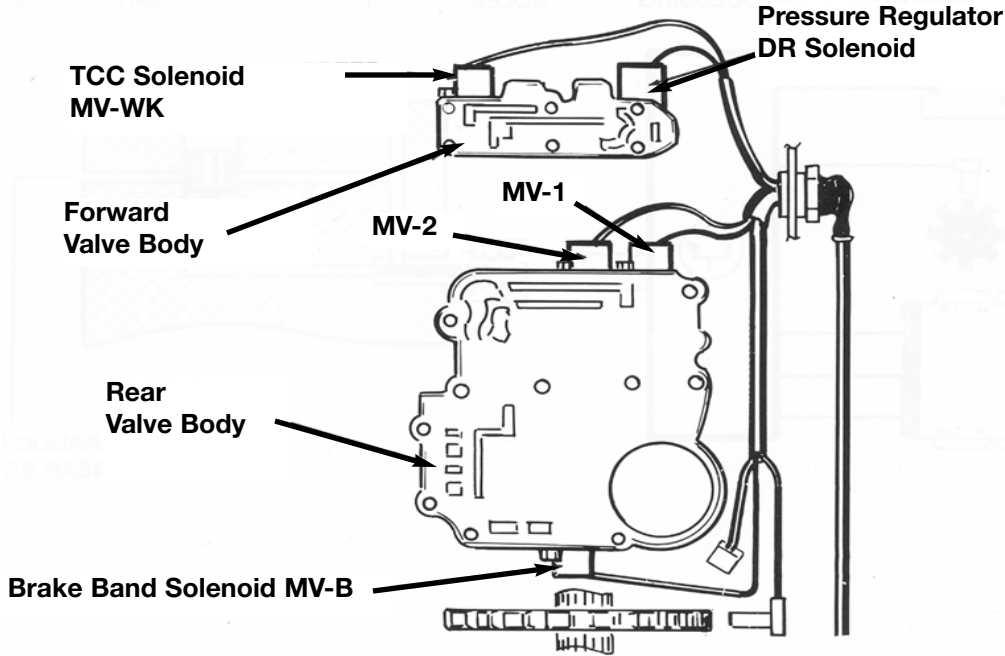
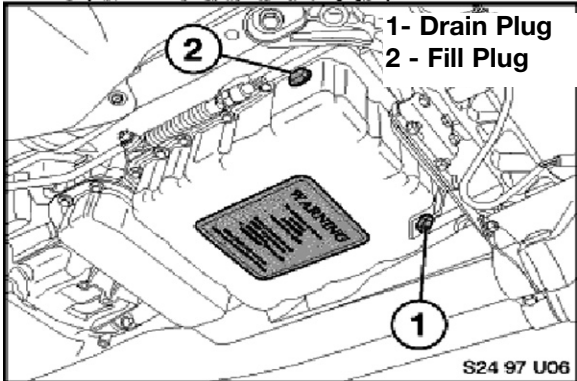

| MV1/MV2 | Pressure Regulator (DR Solenoid) | Brake Band Solenoid (MV-B) | TCC Solenoid (MV-WK) |
|--|--|---|----------------------|
| 17-20 Ohms @ 20°C 21.5-24.5 Ohms @ 80°C | 3.5 - 6.0 Ohms @ 20°C 4.0 - 7.0 Ohms @ 80°C | 9.0-12.0 Ohms @ 20°C 11.5 - 14.5 Ohms @ 80°C | |

A5S440/560Z Component Identification and Ohmic Values

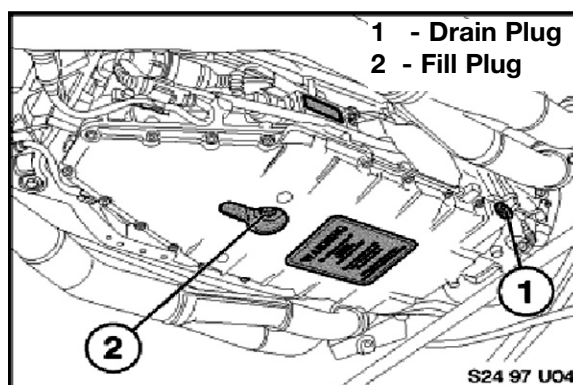
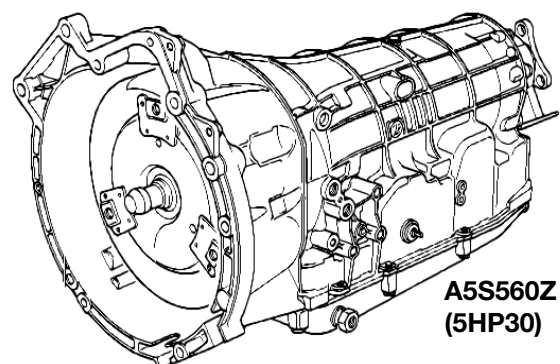
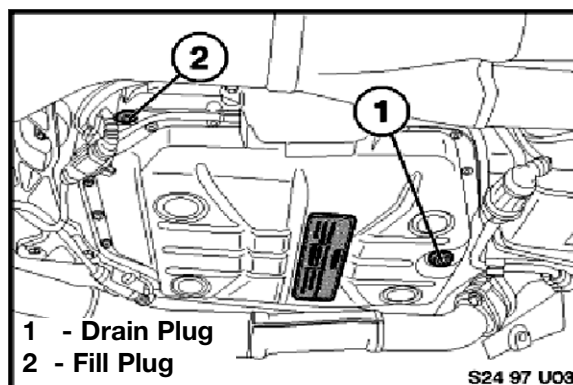
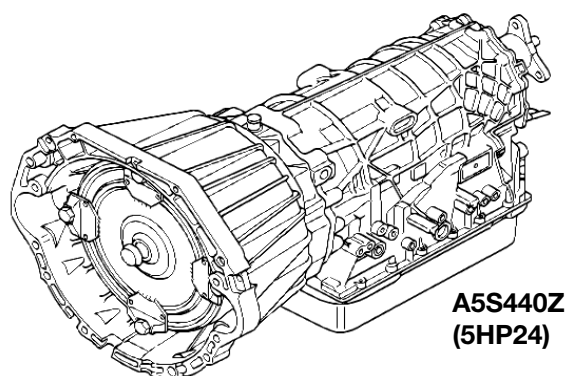

Solenoid Resistance Values

| MV 1 | MV 2 | MV 3 | EDS 1 | EDS 2 | EDS 3 | EDS 4 | EDS 5 |
|------------------|------------------|------------------|--------------------|--------------------|--------------------|--------------------|--------------------|
| 28 Ohms +/- 2 | 28 Ohms +/- 2 | 28 Ohms +/- 2 | 5.9 Ohms +/- .5 | 6.4 Ohms +/- .5 | 6.4 Ohms +/- .5 | 6.4 Ohms +/- .5 | 6.4 Ohms +/- .5 |

| NTC Temp Sensor Values |
|------------------------------|
| 820 Ohms @ 0°C |
| 962 Ohms @ 20°C |
| 1118 Ohms @ 40°C |
| 1289 Ohms @ 60°C |

A5S440/560Z Component Identification and Ohmic Values

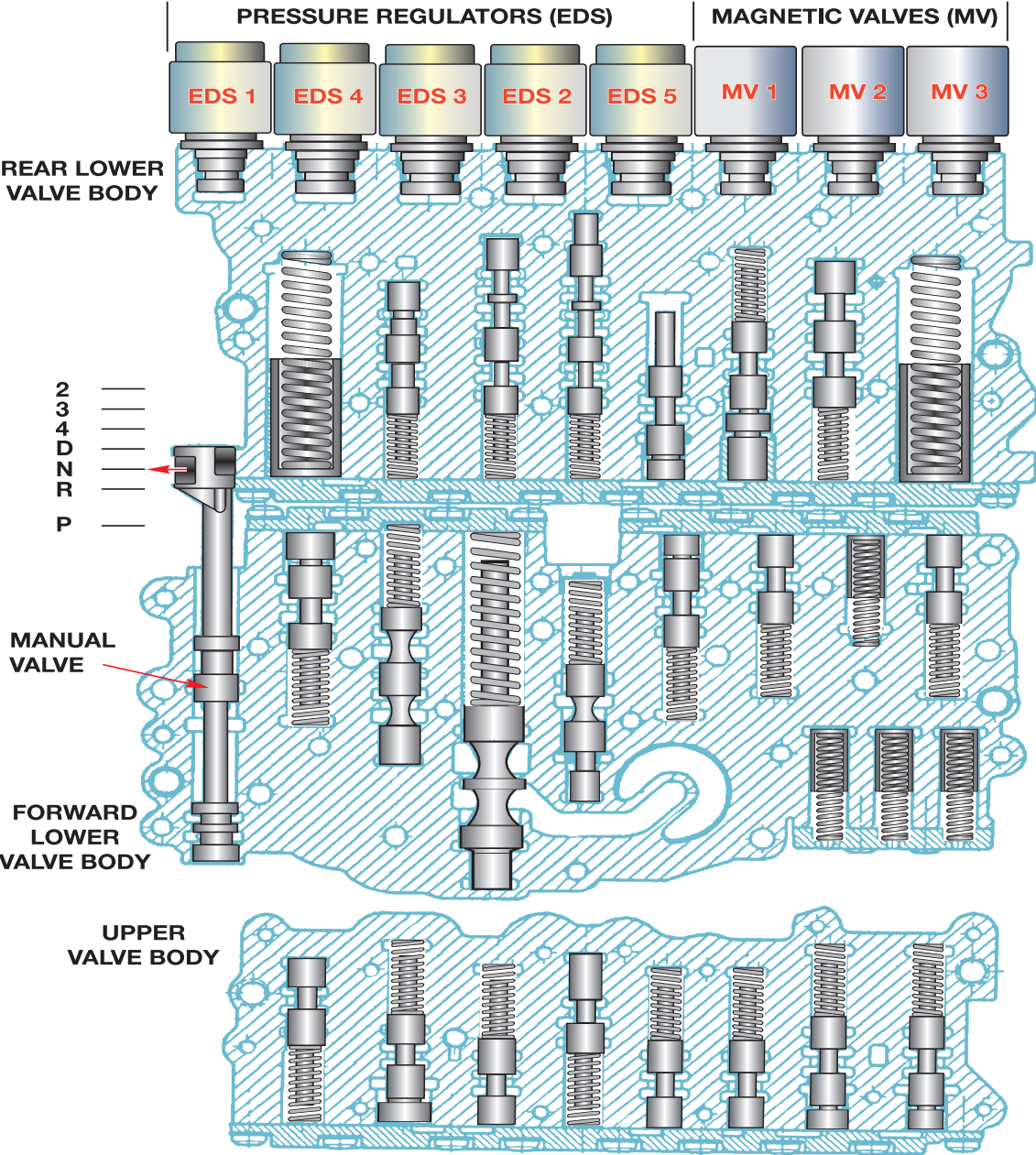

A5S360/390R Component Identification and Ohmic Values

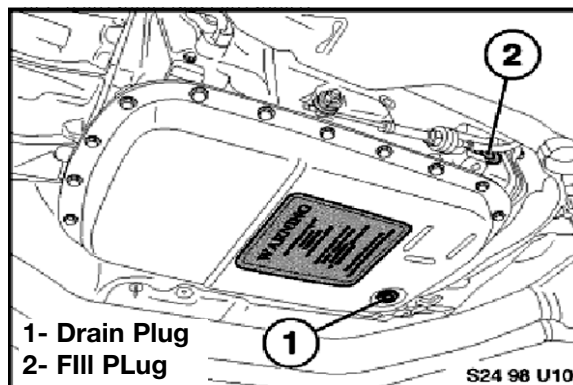
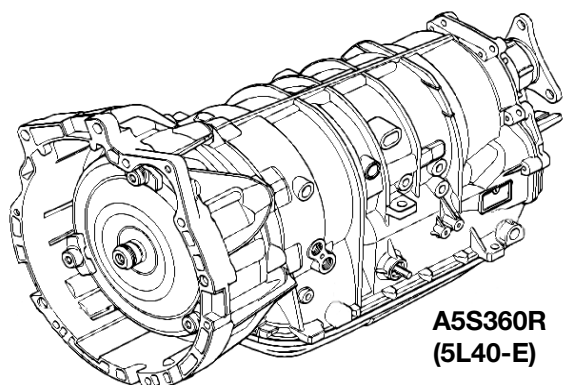

Transmission Oil Temperature Sensor Resistance Values (NTC)

| Temperature Degrees °C | Minimum (Ohms) | Nominal (Ohms) | Maximum (Ohms) | Reference Accuracy (+/-°C) |
|------------------------|----------------|----------------|----------------|----------------------------|
| -30 | 50264 | 52594 | 54924 | 0.7 |
| -20 | 27439 | 28582 | 29725 | 0.7 |
| -10 | 15540 | 16120 | 16700 | 0.7 |
| 0 | 9097 | 9399 | 9701 | 0.6 |
| 10 | 5493 | 5658 | 5823 | 0.6 |
| 20 | 3418 | 3511 | 3604 | 0.6 |
| 30 | 2185 | 2240 | 2295 | 0.6 |
| 40 | 1430 | 1465 | 1500 | 0.6 |
| 50 | 958 | 980 | 1002 | 0.6 |
| 60 | 656 | 671 | 686 | 0.6 |
| 70 | 459 | 469 | 479 | 0.6 |
| 80 | 327 | 334 | 341 | 0.6 |
| 90 | 237 | 242 | 247 | 0.7 |
| 100 | 174 | 178 | 182 | 0.6 |

Shift Solenoid (A-B-C) Resistance Values

| Temperature Degrees °C | Minimum (Ohms) | Nominal (Ohms) | Maximum (Ohms) |
|------------------------|----------------|----------------|----------------|
| 20 | 15 | 16 | 17 |
| 30 | 15.6 | 16.6 | 17.7 |
| 40 | 16.2 | 17.2 | 18.3 |
| 50 | 16.8 | 17.9 | 19.0 |
| 60 | 17.3 | 18.5 | 19.7 |
| 70 | 17.9 | 19.1 | 20.3 |

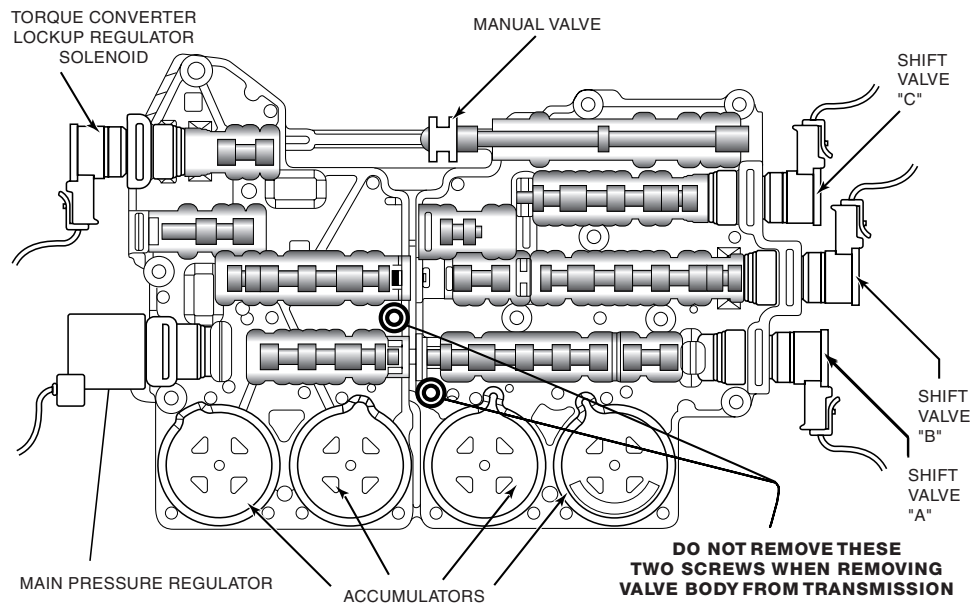

Pressure Regulator Resistance Values

| Temperature Degrees °C | Minimum (Ohms) | Nominal (Ohms) | Maximum (Ohms) |
|------------------------|----------------|----------------|----------------|
| 20 | 3.5 | 4.05 | 4.6 |
| 30 | 3.6 | 4.2 | 4.8 |
| 40 | 3.8 | 4.4 | 5.0 |
| 50 | 3.9 | 4.5 | 5.1 |
| 60 | 4.0 | 4.7 | 5.3 |
| 70 | 4.2 | 4.8 | 5.5 |
| 80 | 4.3 | 5.0 | 5.7 |
| 90 | 4.5 | 5.2 | 5.9 |

TCC Solenoid Resistance

| Temperature Degrees °C | Minimum (Ohms) | Nominal (Ohms) | Maximum (Ohms) |
|------------------------|----------------|----------------|----------------|
| 20 | 9 | 10 | 11 |
| 30 | 9.4 | 10.4 | 11.4 |
| 40 | 9.7 | 10.8 | 11.9 |
| 50 | 10.1 | 11.2 | 12.3 |
| 60 | 10.4 | 11.6 | 12.7 |
| 70 | 10.8 | 12.0 | 13.1 |
| 80 | 11.1 | 12.3 | 13.6 |
| 90 | 11.5 | 12.7 | 14.0 |

Review Questions

1. The identification tag on the A5S440Z is located on _____
2. The 5HP19 transmission uses a _____ turbine speed sensor.
3. The transmission fluid temperature sensor is part of the _____ on the GA6HP26Z transmission.
4. On the GM5 transmission, the transmission range selector switch is located

5. EDS 1 is used for _____ on the 5HP24 transmission.
6. The “Warm up Phase Program” will be terminated if :

7. List the fluid types for the following transmissions:
A5S440Z _____ A5S560Z (late) _____
A5S360R _____ A5S325Z _____
GA6HP26Z _____ A5S310Z _____
8. Line pressure will be at _____ when there is no power to the pressure regulating solenoid.
9. What is the difference in Steptronic operation between a 2001 model year vehicle and a 2002 model year vehicle?

10. The “Curve Recognition” feature compares the _____
to inhibit _____ in a turn.

11. List 5 inputs to the TCM from the ECM over the CAN bus.

12. What SIB refers to "Transmission Fluid Checking Procedures"? _____

13. The Transmission will always default to the _____ Program when started.

14. List the transmissions which use a gradually applied TCC:

15. List 6 items that will occur during failsafe operation:
