

The chart shown below is a quick reference of BMW Engine Management Systems by application to BMW models, engines and model years. This will help you to get familiar with the systems by identifying the correct version that you are diagnosing.

Engine Management Control Versions

VERSIONS	MODEL	ENGINE	MODEL YEAR
Bosch = M Siemens = MS			
M1.2	E32 / M5	M70 / S38	M70 = 1988 - 1999 S38 = 1991 - 1993
M1.7	E31 / E32	M70	1991 - 1994
M1.7	E30	M42	1990 - 1993
M1.7	E36	M42	1992
M1.7	E36	M42 / DISA	1992 - 1995
M1.7.1	E31	S70	1994 - 1995
* M1.7.2	E36	M42 / DISA	1995
M3.1	E34	M50	1991 - 1992
M3.1	E36	M50	1992
M3.3	E32	M60	1993 - 1994
M3.3	E31 / E34	M60	1994 - 1995
M3.3.1	E34 / E36	M50 TU	1993 - 1995
M5.2	E36 / Z3	M44	1996 - 1998
M5.2	E31 / E38 / E39	M62 / M73	1995 - 1997
* MS41.1	E36 / E39 / Z3	M52	1996 - 1998
* MS41.2	E36 M3	S52	1996 - 1998
* M5.2.1	E38 / E39	M62 / M73	> 1998
* MS42	E46 / E39 / Z3	M52TU	1998 - 2000
* MS43	E46 / E39 / E53 / Z3	M54	> 2001
* ME 7.2	E39 / E38 / E53	M62TU	> 1999
* MS S52	E39 (M5) E52 (Z8)	S62	>1999
* MS S54	E46 (M3)	S54	> 2001
* = Systems covered in this course			

Table of Contents

Subject	Page
M1.7.22
Objectives of the Module2
Purpose of the System3
System Components4
Power Supply5
Principle of Operation6
Workshop Hints7
Tools and Equipment8
Air Management9
Principle of Operation13
Workshop Hints16
Tools and Equipment21
Fuel Management22
Principle of Operation31
Workshop Hints37
Tools and Equipment44
Ignition Management47
Principle of Operation54
Workshop Hints57
Tools and Equipment63
Emissions Management65
Evaporative Emissions65
Exhaust Emissions67
Principle of Operation71
Workshop Hints.75
Tools and Equipment77
Performance Controls78
Variant Coding.83
Workshop Hints84
Tools and Equipment85
Review Questions86

M1.7.2

Model: E36-M42 Engine

Production Date: 1995

Manufacturer: Bosch

Pin Connector: 88 Pins

Objectives of the Module

After completing this module, you will be able to:

- Describe the Power Supply for the Fuel Injectors
- Name the Components of the Fuel Supply System
- List the Inputs Required for Ignition Operation
- Describe the Knock Sensor Function
- Name Two Types of Emissions the ECM Controls
- List Two Reasons for the “CHECK ENGINE” Light to Illuminate
- Describe Semi-Sequential Fuel Injection
- Understand How EWS Affects ECM Output Functions to Deter Vehicle Theft

M1.7.2

Purpose of the System

The M1.7.2 system manages the following functions:

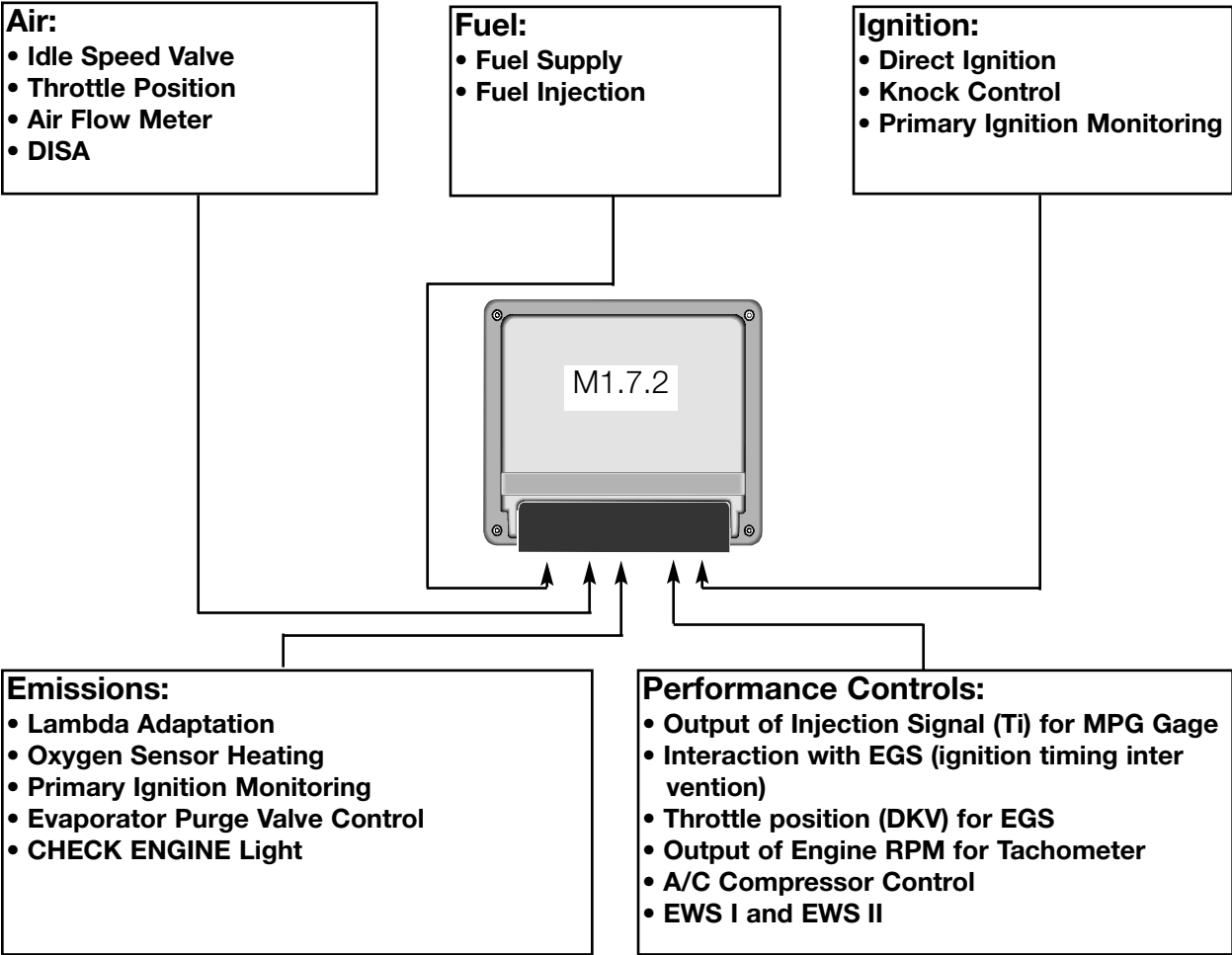

System Components: INPUTS - PROCESSING - OUTPUTS

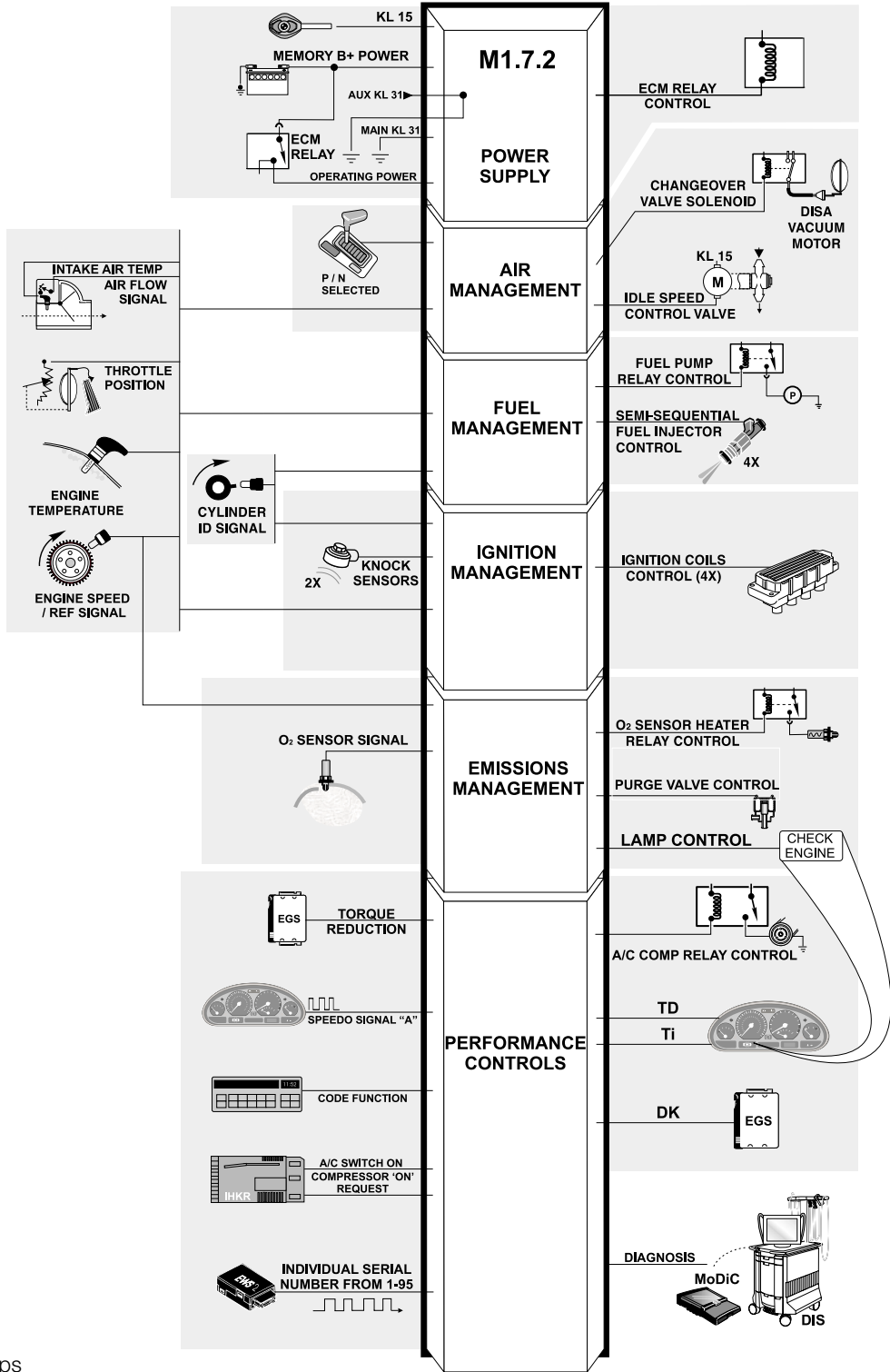

12550012.eps

Power Supply

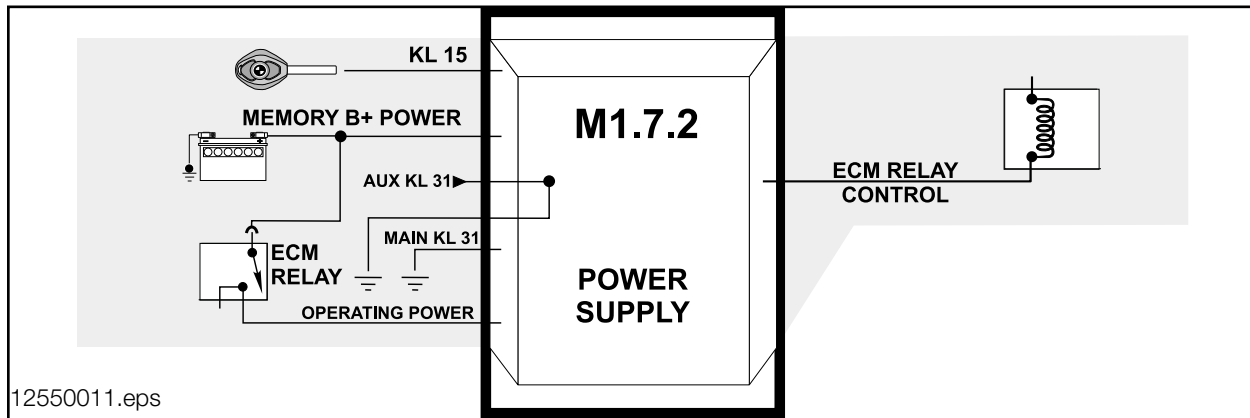

KL30 - Battery Voltage: It supplies the operating voltage to the ECM. Battery voltage also sustains system memory for fault codes and adaptation values.

KL15 - Ignition Switch: When the ignition is switched “on” the ECM is informed that the engine is about to be started. KL15 also supplies voltage to the Engine Control Module Relay. Switching KL15 “off” removes the ECM operating voltage.

Engine Control Module Relay: It provides the operating voltage for:

• ECM	• Fuel Pump Relay
• Fuel Injectors	• Oxygen Sensor Heating
• Idle Speed Valve	• Intake Air Resonance Changeover Valve
• Purge Valve	• EGS “wake up” Call (Terminal 87a)

Ground: Multiple ground paths are necessary to complete current flow through the ECM. The ECM ground pin numbers and functions are:

Pin#	Ground
06	Fuel Injection
28	Electronics and Sensor Shielding
34	Remaining Output Stages (Except Ignition & Injection)
43	Sensors
55	Ignition
71	Oxygen Sensor Signal

Principle of Operation

Battery Voltage is monitored by the ECM for fluctuations. It will adjust the output functions to compensate for a lower (11.7v) and higher (14v) voltage value. For example, the ECM will:

- **Modify Pulse Width Duration of Fuel Injection**
- **Modify Dwell Time of Ignition**

When **KL15** is switched “on” the ECM is ready for engine management. The ECM will activate ground to energize the Engine Control Module Relay. The Engine Control Module Relay supplies operating voltage to the ECM and the previously mentioned operating components.

When **KL15** is switched “off” the ECM operating voltage is removed. The ECM will maintain a ground to the Engine Control Module Relay for a few seconds to hold the Evaporative Purge Valve closed (to prevent engine run on).

Ground is required to complete the current path through the ECM. The ECM also:

- **Internally links a constant ground (1) to the engine sensors.**
- **Switches ground (2) to activate components**

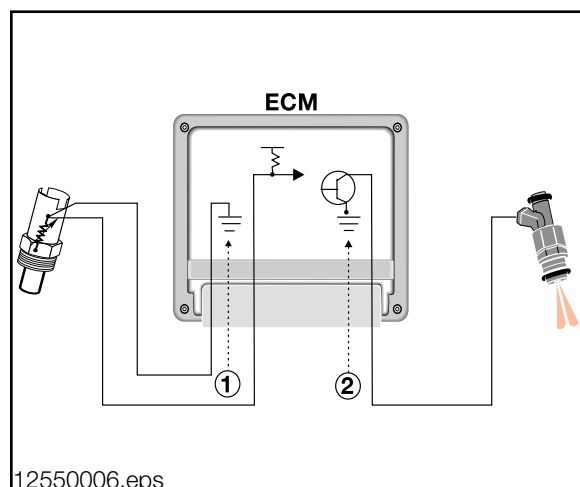

Workshop Hints

Power Supply - Testing

Inadequate power and ground supply can result in:

- | |
|---|
| • No Start |
| • Hard Starting (Long Crank Times) |
| • Inaccurate Diagnostic Status or ECM Not Found |
| • Intermittant/Constant Check Engine Light |
| • Intermittant/Constant Driveability Problems |

Power supply including fuses should be tested for:

- | |
|---|
| • Visual (1) Blown Fuse |
| • Available Voltage 2 |
| • Voltage Drop (Dynamic Resistance) (2) |
| • Resistance of Cables and Wires (2) |

The ignition (KL15) must be switched off when removing or installing the ECM connector to prevent voltage spikes (arcing) that can damage the Control Module!

The Engine Control Module Relay (located in the fuse box) should be tested for:

- | |
|---|
| • Battery Voltage and Switch Ground (1) |
| • Resistance (1) |
| • Battery Voltage and Voltage Drop (2) |

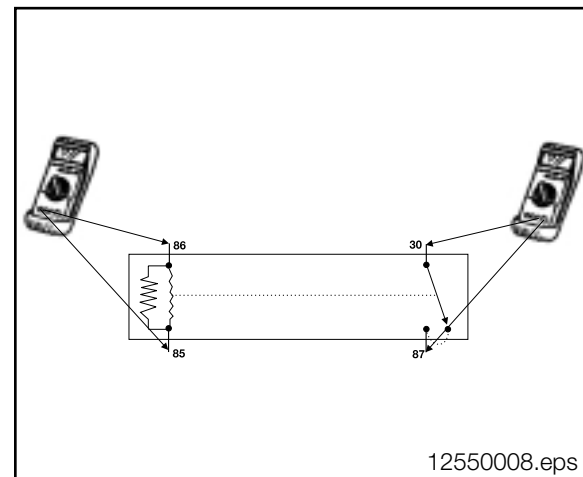
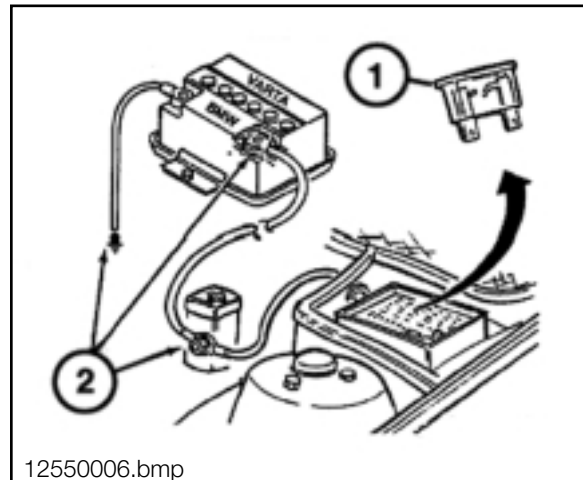
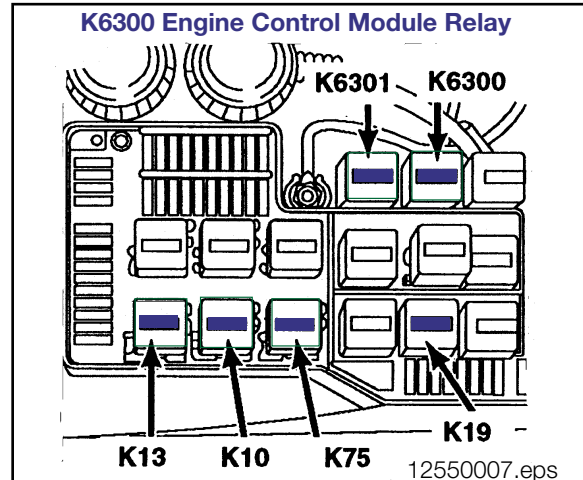

Tools and Equipment

Power Supply

When testing power supply to an ECM, the DIS/MoDIC multimeter function as well as a reputable hand held multimeter can be used.

It is best to make the checks at the ECM connection, this method includes testing the wiring harness.

The correct Universal Adapter for the M1.7.2 application should be used (#88 88 6 614 410). This will ensure the pin connectors and the harness will not be damaged.

The interior of this Universal Adapter is shielded, therefore it is vital that the ground cable is connected to the vehicle chassis whenever the adapter is used.

The adapter uses a Printed Circuit board inside keeping the capacitive and inductive load to a minimum.

When installing the Universal Adapter to the ECM (located below the windshield on the passenger side of the engine compartment), make sure the ignition is switched off.

The Engine Control Module **Relay** should be tested using the relay test kit (P/N 88 88 6 613 010) shown on the right.

This kit allows testing of relays from a remote position.

Always consult the ETM for proper relay connections.

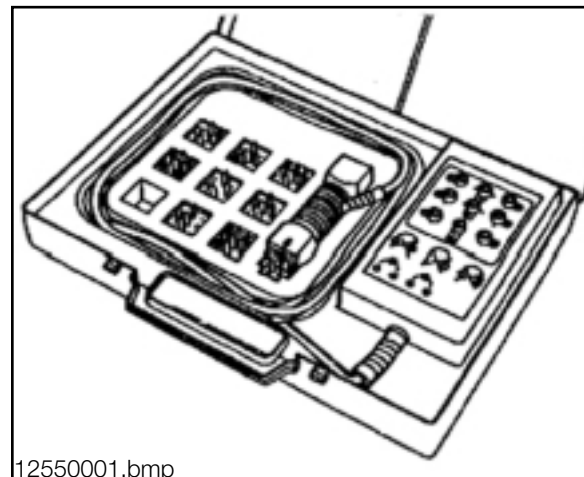
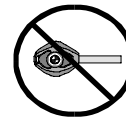
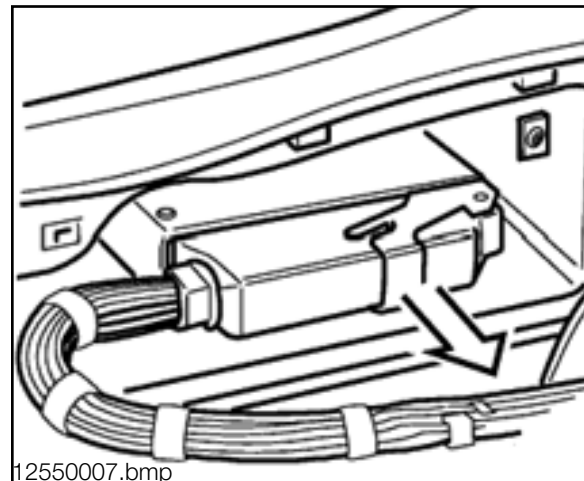
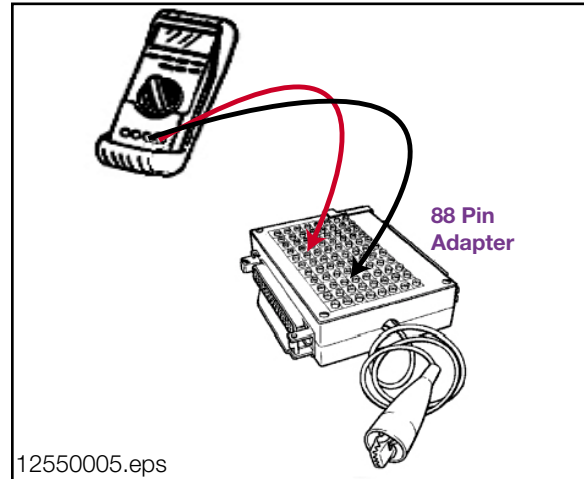

Air Management

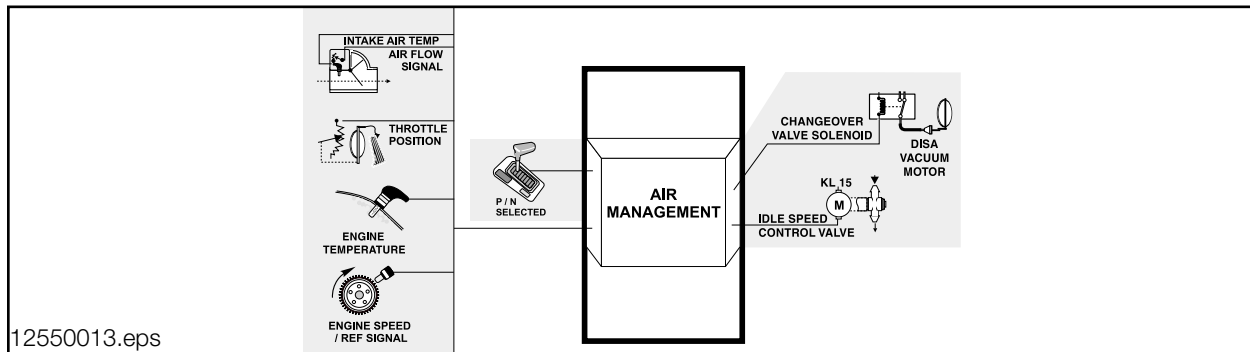

Throttle Valve: The mechanical throttle valve regulates the intake air flow and it is linked by a cable to the accelerator pedal.

The throttle valve is a two stage (progressive linkage) plate arrangement with integral closing springs. This allows a smaller primary opening (1) for low to mid-range rpm and a larger secondary opening (2) that opens for the higher rpm range.

The throttle valve is heated by engine coolant to prevent condensation from “icing”. The throttle valve is “preset” and should not be adjusted.

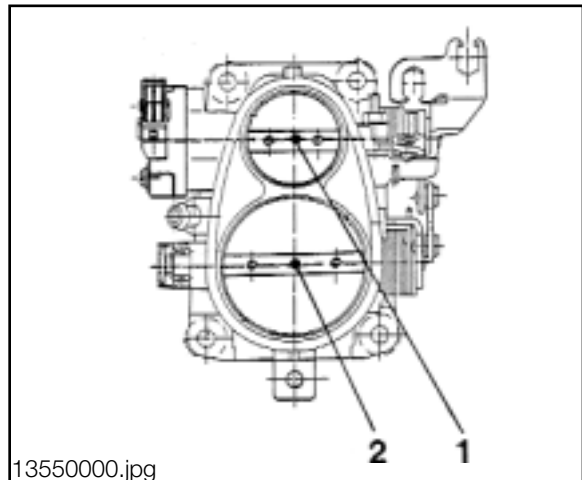

Throttle Position Sensor: A potentiometer is mounted on the throttle housing which provides the ECM with a voltage value (0-5v) that represents throttle angle position and rate of movement. The sensor receives its power supply from the ECM.

The Potentiometer is non-adjustable because the ECM “learns” the throttle angle voltage at idle speed. If the throttle position sensor is replaced, the ECM must be disconnected from the power supply for at least one minute (to clear memory).

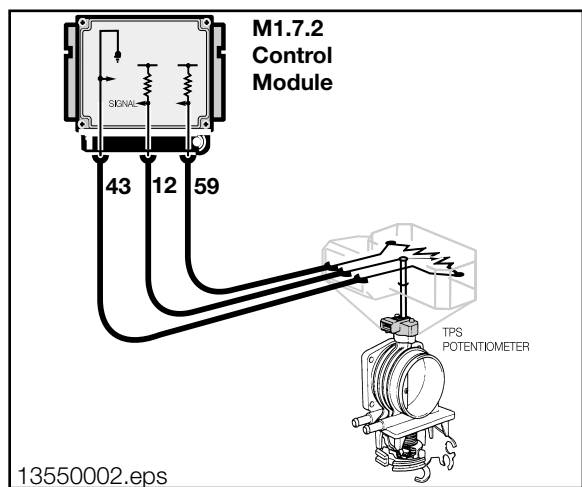

Idle Speed Control Valve: This is a two wire control valve that regulates air by-passing the throttle valve to control the engine idle speed.

The idle speed control valve is spring loaded closed. It will “failsafe” to a fixed opening (21%) to allow the engine to idle in the event of a power failure.

The valve is supplied with battery voltage from the Engine Control Module Relay. The valve opening is controlled by the ECM modulating the ground signal which opens the valve against spring tension.

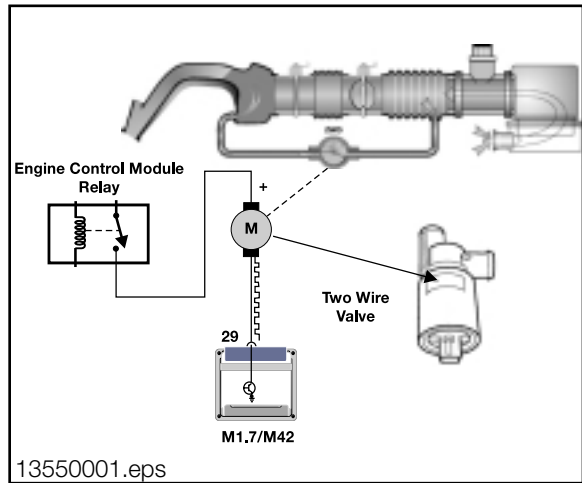

Air Flow Volume Sensor: This sensor measures the total volume of air drawn into the engine.

The ECM provides the power supply for the Air Flow Volume Sensor. A potentiometer is connected to the sensing flap and as air flow causes the sensing flap to move, a varying voltage signal (0-5v) is sent to the ECM that “represents” the inducted air volume.

Attached to the sensing flap is a “compensation flap” that moves within a closed chamber. This creates a dampening effect on flap movement for pulsations in the intake system caused by cylinder filling and intake valve operation.

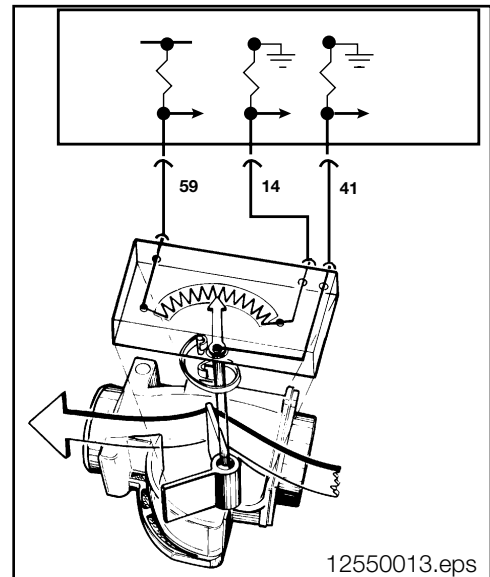

NOTE: The Air Flow Volume Sensor is non-adjustable.

Air Temperature Signal: The Air Flow Volume Sensor contains an integral air temperature sensor. This signal is needed by the ECM to correct the air volume input for changes in the intake air temperature (air density).

The sensor is located in front of the measuring flap. The ECM provides the power supply to this component. The sensor decreases in resistance as the temperature rises and vice versa (NTC). The ECM monitors an applied voltage to the sensor (5v) that will vary as air temperature changes the resistance value (0-5v).

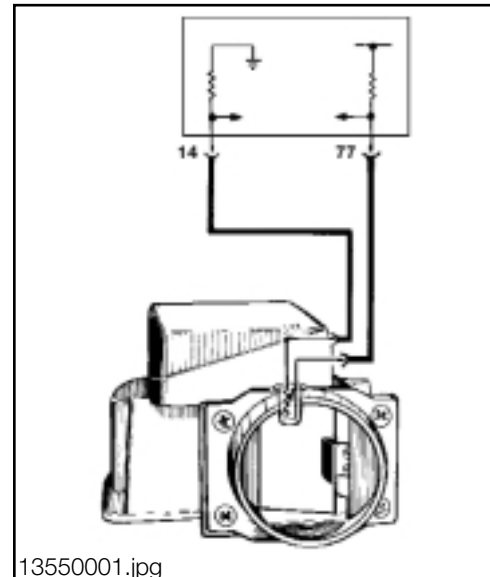

Differential Air Intake System (DISA): DISA allows the dynamics of varied intake manifold tuning. This feature provides necessary intake air “velocity” producing good mid-range torque. Additionally, DISA can divert intake air flow providing “volume” for higher rpm requirements.

The ECM closes the changeover valve to take advantage of a long single intake runner at mid-range RPM. This produces air **velocity** that increases engine torque at mid-range.

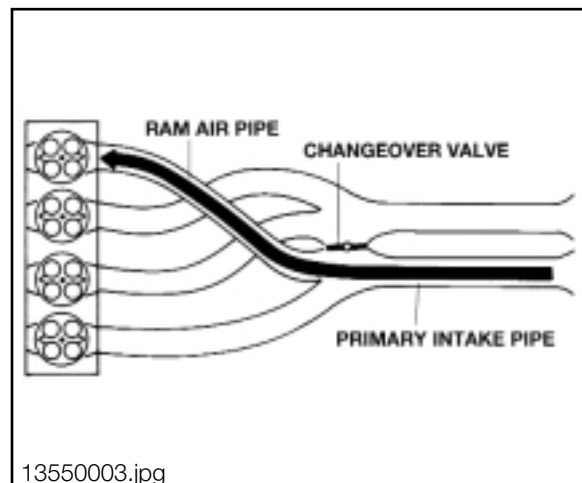

At high rpm, the ECM opens the changeover valve allowing the engine breathing dynamics to change to the dual short air pipes (**volume**). This change enables additional power output at the higher RPM range.

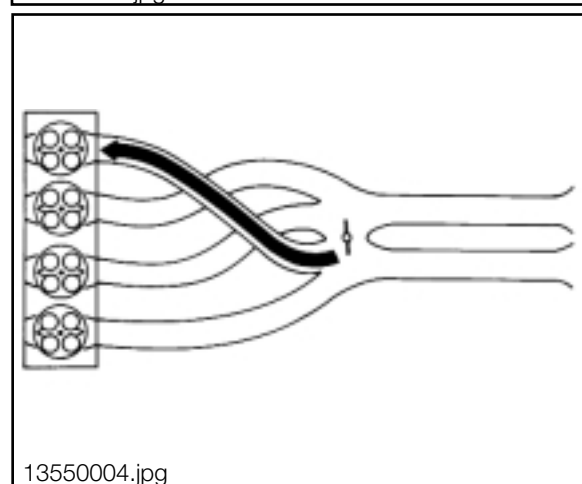

To accomplish this function, the M42 intake manifold incorporates a non-replaceable brass change over valve.

The DISA system vacuum components are:

• Motor (actuator)	• Reservoir
• Solenoid	• Check Valve

The solenoid receives voltage from the Engine Control Module Relay and the ECM controls the ground supply to activate the solenoid.

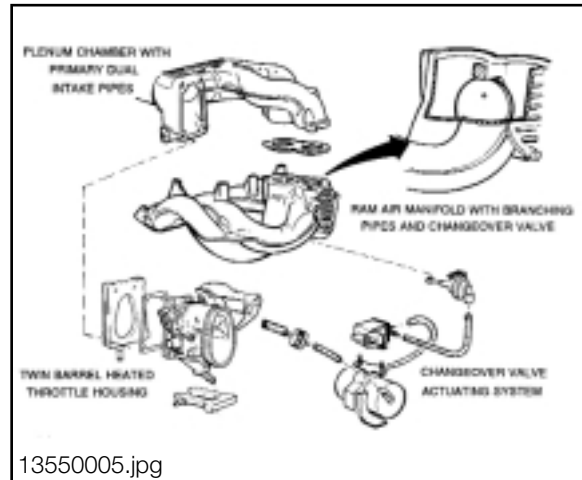

Pressure Control Valve: The pressure control valve varies the vacuum applied to the crankcase ventilation depending on engine load. The valve is balanced between spring pressure and the amount of manifold vacuum.

The oil vapors exit the separator labyrinth in the cylinder head cover (1). The oil vapors are drawn into the intake manifold (3) regulated by the pressure control valve (2).

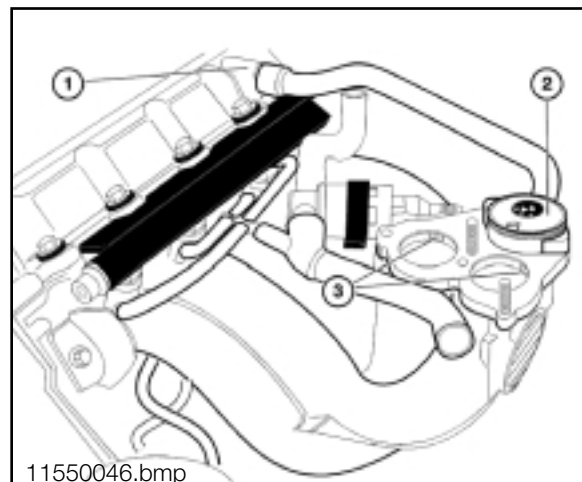

At idle when the intake manifold vacuum is high, the vacuum decrease the valve opening and only allows a small amount of crankcase vapors to be drawn into the intake manifold.

At part to full load conditions when intake manifold vacuum is lower, the spring opens the valve and additional crankcase vapors are drawn into the intake manifold.

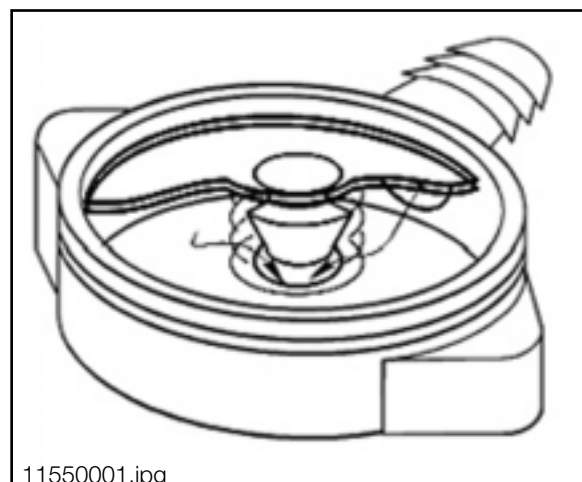

Principle of Operation

Air flow into the engine is regulated by the Throttle Valve or the Idle Speed Control Valve. Both of these air “passages” are necessary for smooth engine operation from idle to full load. On the M1.7.2 system, the Throttle Valve is **mechanically controlled** and the Idle Speed Control Valve is **electrically controlled**. All of the ECM monitoring, processing and output functions are a result of regulated air flow.

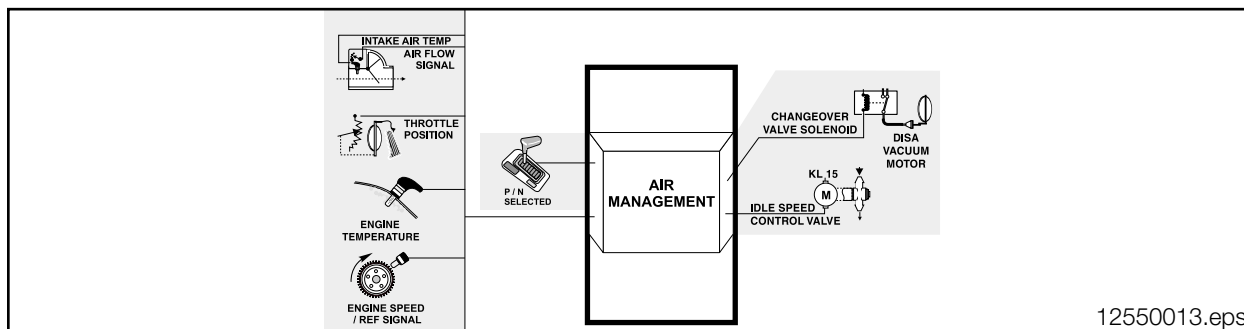

The Throttle Position Sensor is monitored by the ECM for throttle angle position and rate of movement. As the throttle plate is opened, a rising voltage signal (up to 5v) requests acceleration and at what rate. The ECM will increase the volume of fuel injected into the engine, advance the ignition timing and decrease the Idle Speed Valve opening (air is now going by the throttle plate). The “full throttle” position indicates maximum acceleration to the ECM, this will have an effect on the A/C compressor (covered in Performance Controls).

As the throttle plate is closed (integral springs), a decrease in voltage signals the ECM to activate fuel shut off if the rpm is above idle speed (coasting). The Idle Speed Control Valve will then be opened to maintain idle speed.

The ECM monitors the engine idle speed in addition the Throttle Position Sensor voltage. The voltage value is “learned” at the correct idle speed and if the voltage value has changed (mechanical wear of throttle plate or linkage), the ECM will adjust the Idle Speed Control Valve to maintain the correct idle speed based on the “new” voltage. To clear this “learned” value, disconnect the ECM for at least one minute. If the Throttle Position input is defective, a fault code will be set and the “CHECK ENGINE” Light will illuminate. The ECM will maintain engine operation based on the Air Flow Volume Sensor and the Engine RPM Sensor.

The Idle Speed Control Valve is controlled by the ECM modulating the ground signal to the valve, opening it against spring pressure. By varying the duty cycle applied to the winding, the valve can be progressively opened, or held steady to maintain the idle speed. If the Idle Speed Control Valve circuit is defective, a fault code will be set and the “CHECK ENGINE” Light will illuminate. The valve will spring to the fixed opening, allowing the engine to idle.

There are additional factors that influence the ECM in regulating idle speed:

- **The RPM sensor input allows the ECM to monitor engine speed because of loads that cause idle fluctuations due to drag on the engine: power steering, thick oil (fractional forces), etc.**
- **Cold engine temperature (coolant NTC) provides higher idle speed to raise temperature sooner.**
- **Vehicle speed informs ECM when the vehicle is stationary and requires idle maintenance**
- **A/C on request from the climate control system (arming the ECM) and compressor engage (stabilize idle speed) acknowledgment.**
- **Range selector provides a Park/Neutral input to the ECM identifying when the vehicle is in a drive gear. This signal allows idle stabilization for the increased load on the engine.**

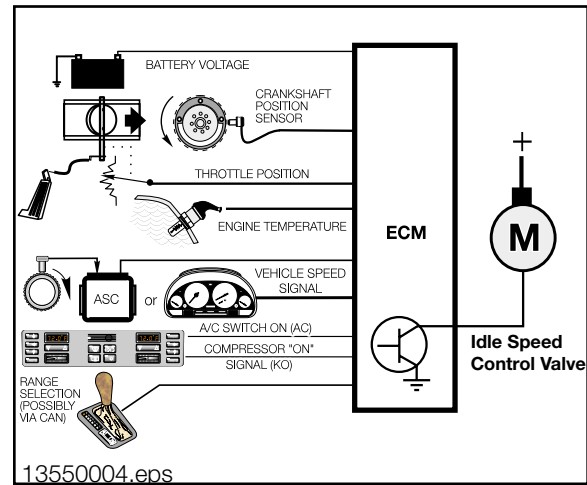

The Air Flow Volume Sensor sends a varying voltage (0-5v) to the ECM representing the measured amount of intake air volume. This input is used by the ECM to determine the amount of fuel to be injected. If this input is defective, a fault code will be set and the “CHECK ENGINE” Light will illuminate. The ECM will maintain engine operation based on the Throttle Position Sensor and Engine RPM Sensor.

The Air Temperature Signal allows the ECM to make a calculation of air density. The varying voltage input from the NTC sensor indicates the larger proportion of oxygen found in cold air, as compared to less oxygen found in warmer air. The ECM will adjust the amount of injected fuel because the quality of combustion depends on oxygen sensing ratio.

The ignition timing is also affected by air temperature. If the intake air is hot the ECM retards the base ignition timing to reduce the risk of detonation. If the intake air is cooler, the base ignition timing will be advanced. If this input is defective, a fault code will be set and the “CHECK ENGINE” Light will illuminate.

DISA is controlled by the ECM activating the Change Over Solenoid below 4,840 RPM.

- When activated the solenoid applies vacuum to the change over valve and the valve closes, providing the long pipe effect.
- Above the RPM, the solenoid is switched off and the Change Over Valve springs opens, providing the short pipe effect.
- On decel, the solenoid will not be activated until 4,760 RPM. This over lap prevents repeated opening and closing of the valve while driving at a constant engine speed of 4800 rpm.

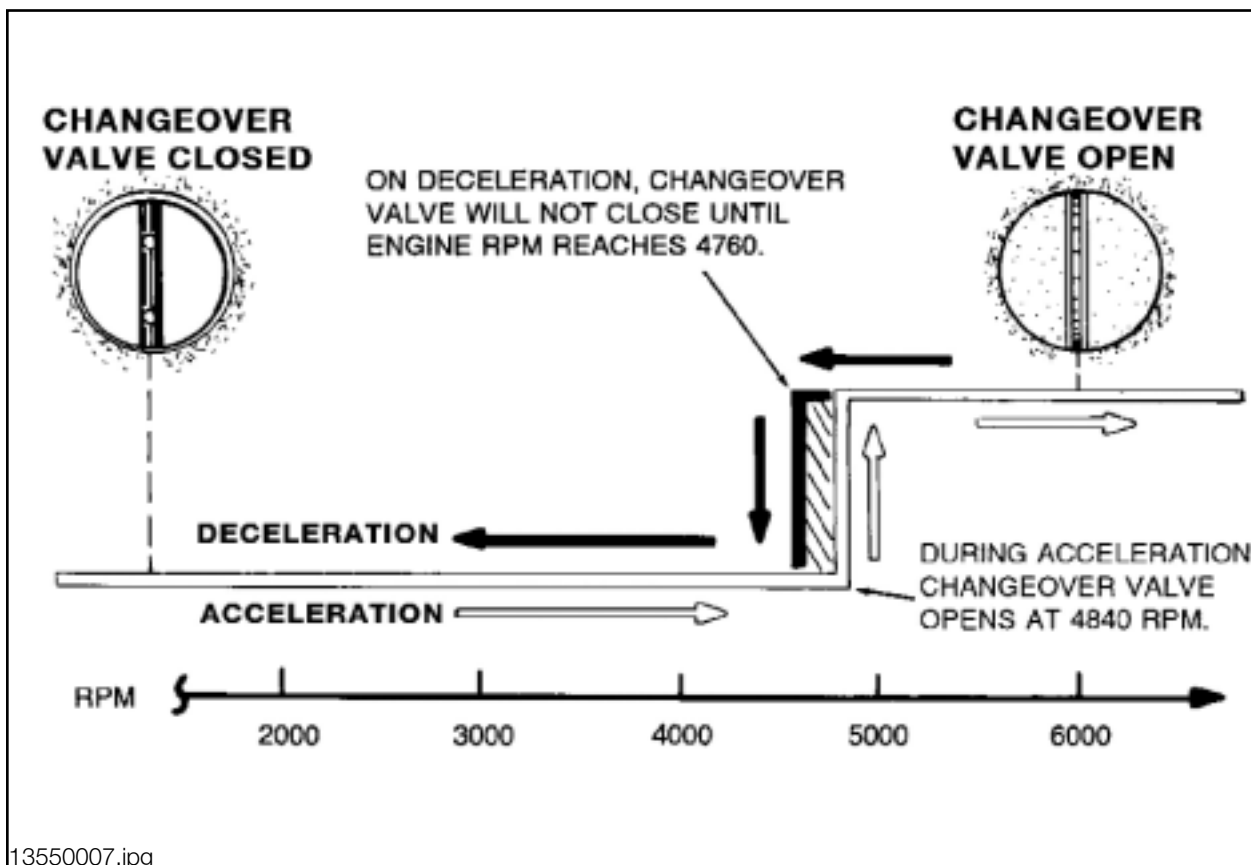
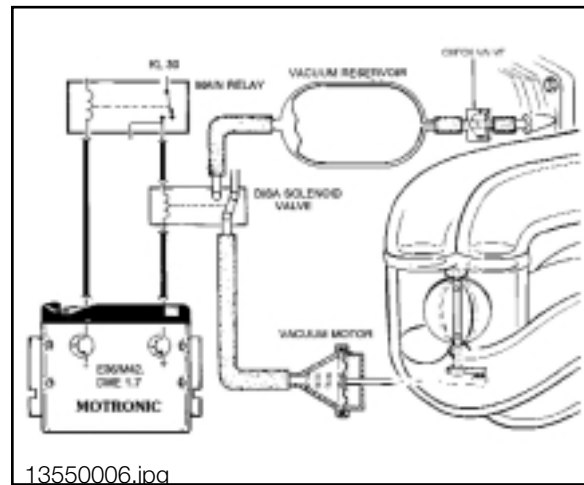

If there is a defect in this system, the Changeover Valve will be opened to ensure intake air availability for maximum power (short pipe affect). The Vacuum Motor and valve shaft are both spring loaded to open the Changeover Valve if vacuum is not applied.

Workshop Hints

Air Management

Unmetered air leaks can be misleading when diagnosing faults causing Check Engine Light/driveability complaints. Refer to S.I. # 11 03 92 (3500) for testing intake vacuum leaks.

Crankcase Ventilation System

A fault in this system can often “mislead” diagnosis. This type of fault can produce:

• Mixture/Misfire Defect Codes
• Whistling Noises
• Performance/Driveability Complaints

Please refer to the following Service Information Bulletins for details on the **Crankcase Ventilation System**:

• Crankcase Ventilation System Check S.I. #11 05 98
• Throttle Housing Recall Campaign (Crankcase Ventilation Routing) S.I. #13 06 91 (3440)

Throttle Valve and Throttle Position Sensor

These components are non-adjustable and tampering is not permitted. However, the attaching throttle and cruise control cables should be adjusted (refer to Repair Instructions).

Please refer to the following Service Information Bulletins for details on the **Throttle Valve Housing and Throttle Position Sensor**:

• Increase Pedal Effort S.I. #13 03 94 (4042)
• Throttle Body Recall Campaign (Throttle Body Heater) S.I. #13 02 94 (3980)
• Throttle Potentiometer - Fault code 12 S.I. #13 09 90 (3141)

Throttle Position Sensor - Testing

The Throttle Position Sensor (potentiometer) can be tested with the following methods:

- **DIS Status Page (approx. 0.6v idle to 4.2v full throttle).**
- **DIS Oscilloscope - Select from the Preset Measurements which requires taking the measurement with the ECM and Universal Adapter connected to the circuit.**
- **Resistance check of the entire circuit, using the Universal Adapter with the ECM disconnected (approx. 1-4 K ohms).**

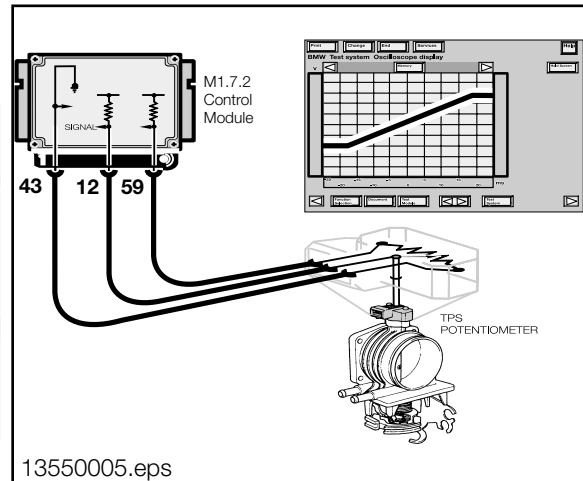

Idle Speed Control Valve - Testing

- **The Idle Speed Control Valve and idle air circuit (passage ways) should be checked for physical obstructions.**
- **The resistance of the valve winding should be checked (8 +/-2 ohms).**
- **The ECM output and Idle Speed Control Valve operation can be tested by "Component Activation" on the DIS/MoDIC.**
- **The Pulse Width Modulated ground output from the ECM can be tested using the DIS/MoDIC Oscilloscope.**
- **Consult Technical Data for specified idle speed.**

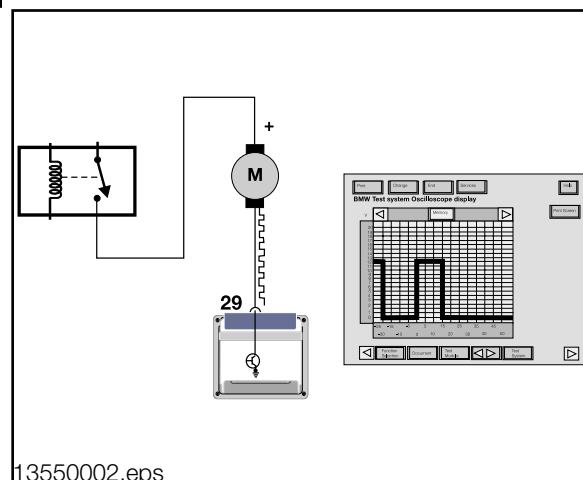
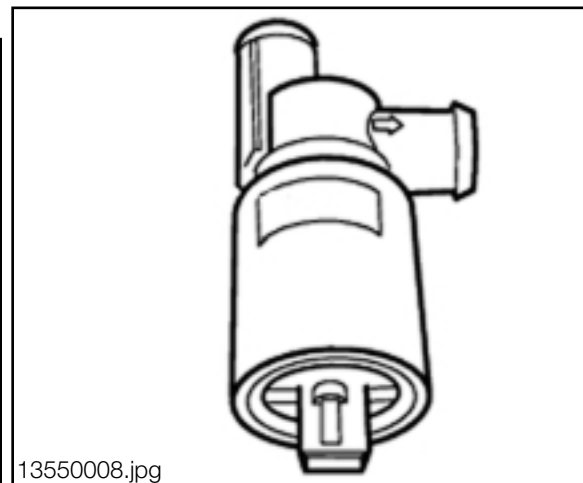

Air Flow Volume Sensor

This component is non-adjustable and tampering is not permitted.

A faulty Air Flow Volume Sensor can produce the following complaints:

- | |
|---|
| • Difficult To Restart When Engine Is Hot |
| • Engine Starts Then Stalls |
| • “CHECK ENGINE” Light Illuminated |
| • Engine Starts And Runs Only With Accelerator Pedal Depressed |

Please refer to the following Service Information Bulletin for details on the Air Flow Volume Sensor:

- | |
|---|
| • Fault Code “41” S.I. #12 09 95 |
|---|

Some early versions have been modified with an additional harness. This is a BMW approved modification, refer to S.I. #13 03 91 (3290) for details.

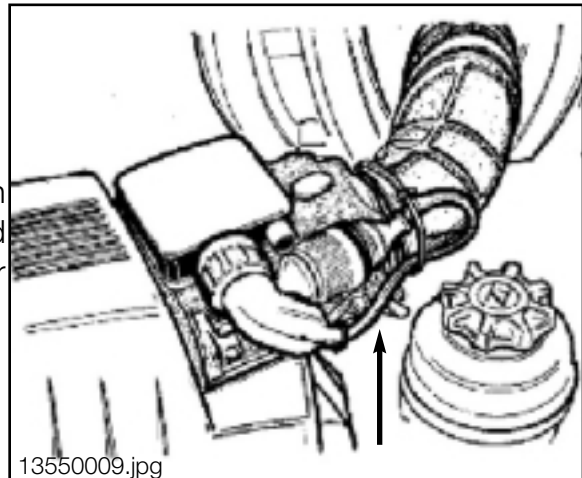

The Air Flow Volume Sensor should be checked for:

- | |
|------------------------------|
| • Code Number (1) |
| • Production Date (2) |

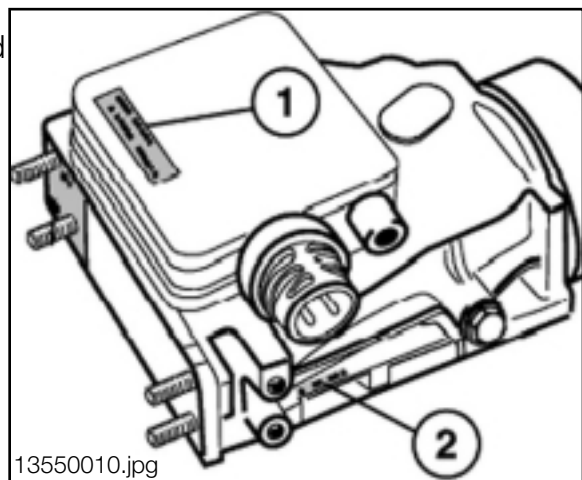

Air Flow Volume Sensor - Testing

The Air Flow Volume Sensor (potentiometer) can be tested with the following methods:

- **DIS Status Page (Up/Uv Ratio 0.1 - 0.3 at idle speed).**
- **DIS Oscilloscope - Select from the Preset Measurements which requires taking the measurements with the ECM disconnected and the Universal Adapter connected to the circuit.**
- **Resistance check of the entire circuit, using the Universal Adapter with the ECM disconnected.**

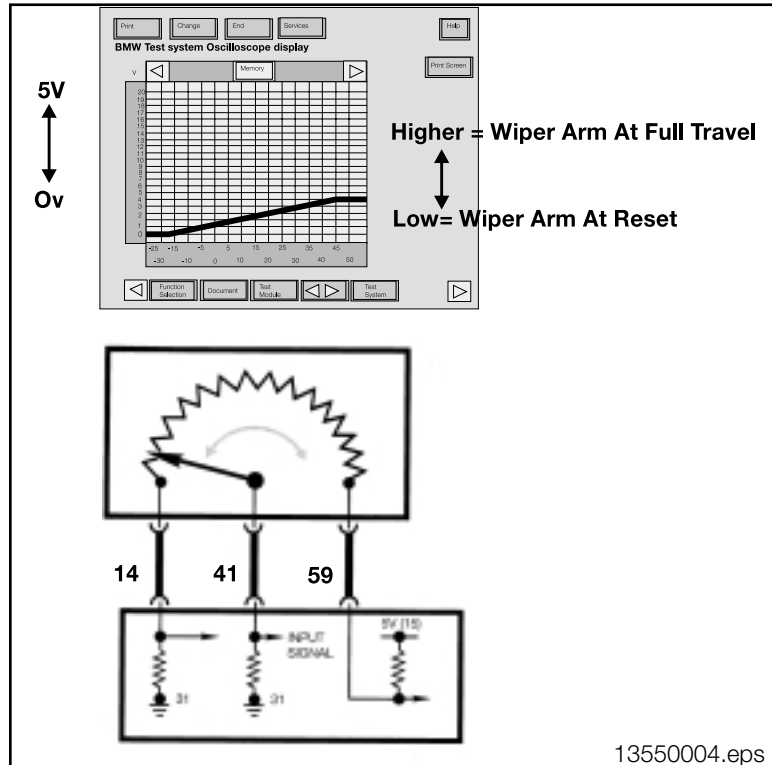

Air Temperature Signal - Testing

NTC sensors decrease in resistance as the temperature rises and vice versa. The ECM monitors the sensor voltage which varies as temperature changes the resistance value. For example, as temperature rises:

- **Resistance through the sensor decreases.**
- **Voltage drop across the sensor decreases.**
- **Input signal voltage also decreases (5-0v).**

This Sensor should be tested using:

- **DIS/Modic Status page.**
- **DIS/Modic Multimeter At 20° C 2.2 - 2.7 k ohms**

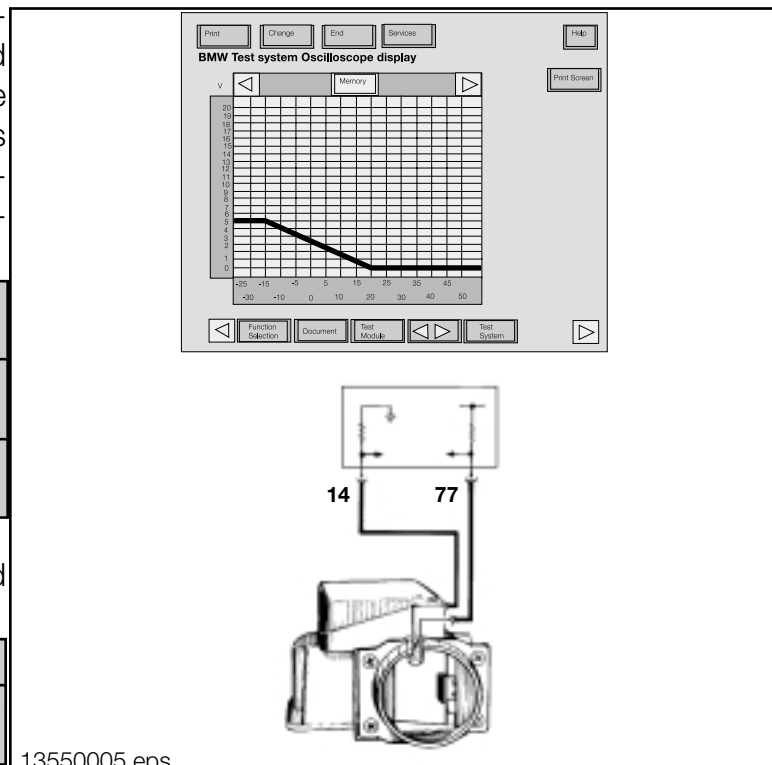

13550005.eps

DISA - Testing

The DISA System can be tested by raising the RPM to 4,840 (briefly) and visually checking the Vacuum Motor Actuator Arm for movement.

If the Actuator Arm does not move, repeat test and check for vacuum at:

• Vacuum Motor
• Solenoid Valve
• Reservoir

Repeat the test to verify the ECM is providing a ground signal to the Solenoid Valve.

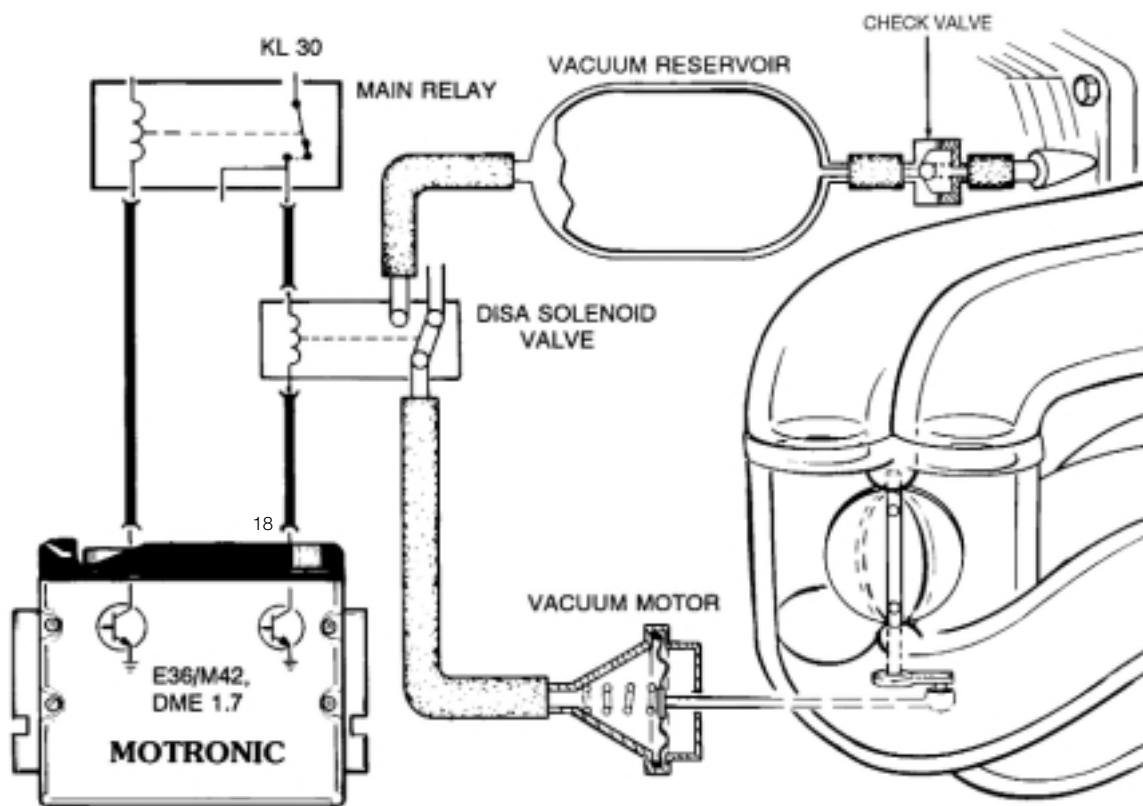

13550011.jpg

Tools and Equipment

The DIS/Modic as well as a reputable hand held multimeter can be used when testing inputs/components.

It is best to make the checks at the ECM connection, this method includes testing the wiring harness.

The correct Universal Adapter for the M1.7.2 application should be used (#88 88 6 614 410). This will ensure the pin connectors and the harness will not be damaged.

The interior of this Universal Adapter is shielded, therefore it is vital that the ground cable is connected to the vehicle chassis whenever the adapter is used.

The adapter uses a Printed Circuit board inside keeping the capacitive and inductive load to a minimum.

When installing the Universal Adapter to the ECM (located below the windshield on the passenger side of the engine compartment), make sure the ignition is switched off.

The Slack Tube Manometer Test Tool (#99 00 0 001 410) should be used to troubleshoot crankcase ventilation valves.

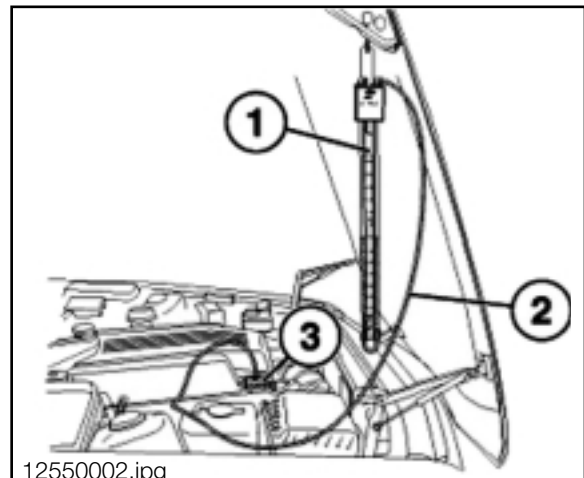
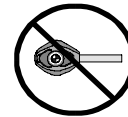
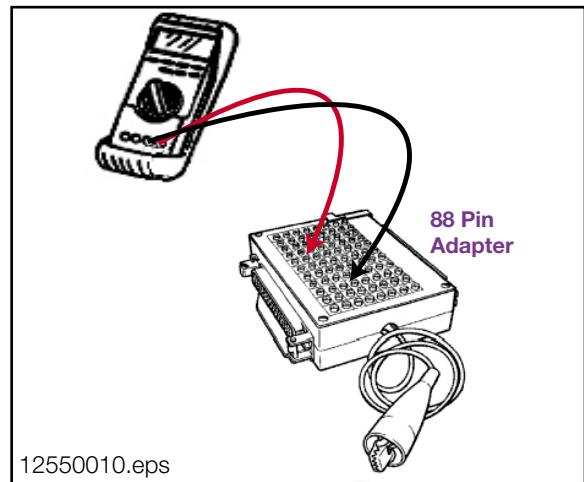
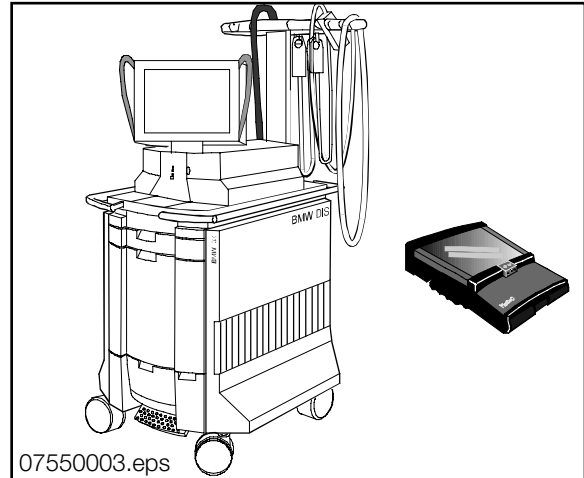

Fuel Management

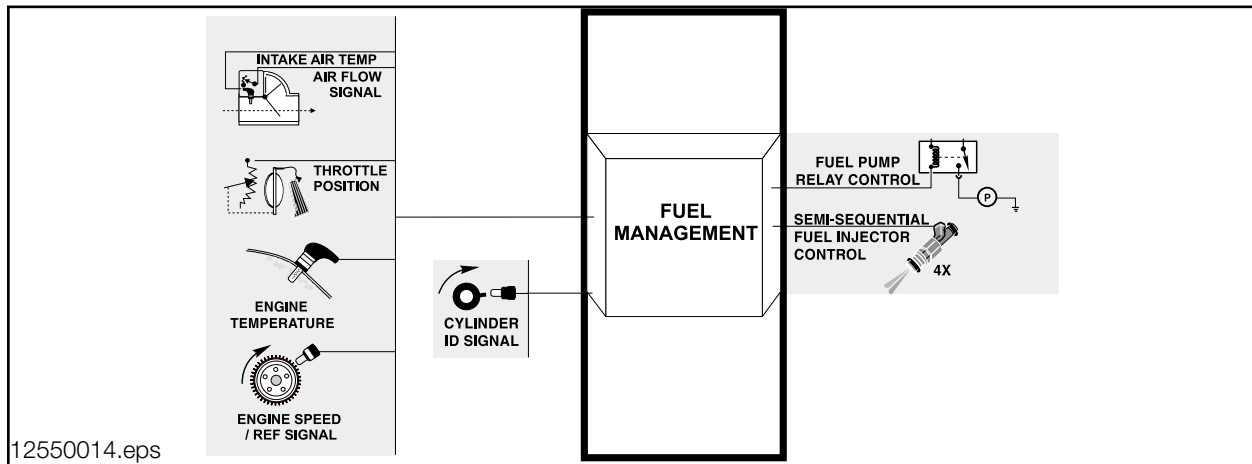

Fuel Tank: The fuel tank is made of high density polyethylene (reduced weight) which is manufactured to meet safety requirements.

A “saddle” type tank is used which provides a tunnel for the driveshaft but creates two separate low spots in the tank.

A Syphon jet is required with this type of tank to transfer fuel from the left side, linked to the fuel return line.

As fuel moves through the return, the syphon jet creates a low pressure (suction) to pick up fuel from the left side of the tank and transfer it to the right side at the fuel pick up.

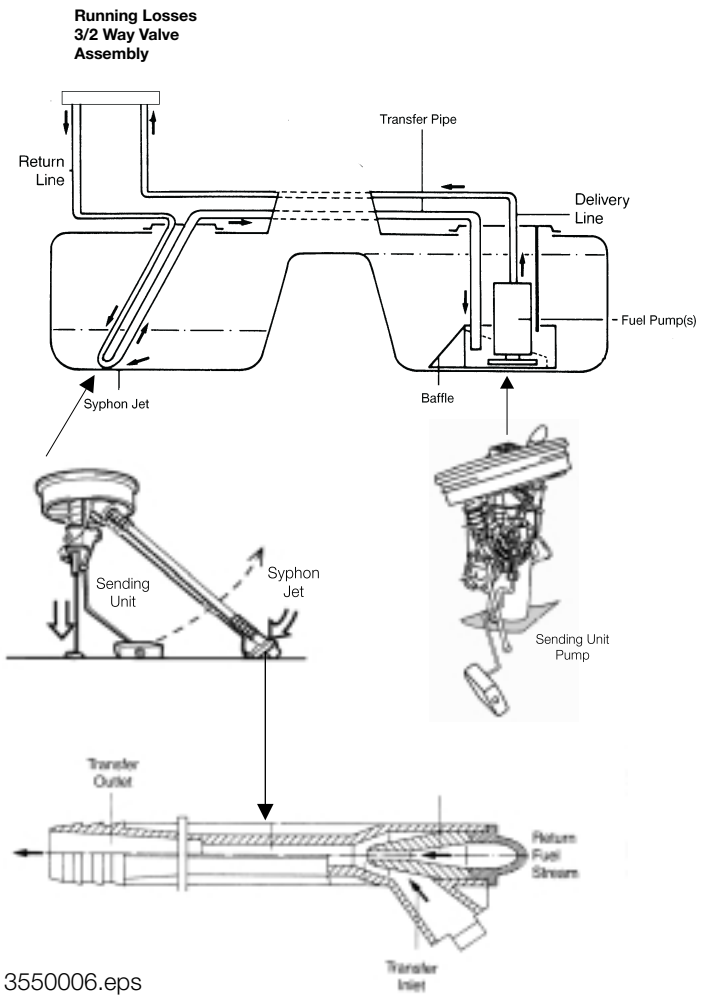

Fuel Pump: The electric fuel pump supplies constant fuel volume to the injection system. This system uses a single submersible (in the fuel tank) pump. The inlet is protected by a mesh screen.

When the fuel pump is powered, the armature will rotate the impeller disk creating low pressure at the inlet. The fuel will be drawn into the inlet and passed through the fuel pump housing (around the armature). The fuel lubricates and cools the internals of the pump motor.

The fuel will exit through a non-return check valve to supply the injection system. The non-return check valve is opened by fuel exiting the pump and will close when the pump is deactivated. This maintains a “prime” of fuel in the filter, lines, hoses and fuel rail.

The pump contains an internal overpressure relief valve that will open (reducing roller cell pressure) if there is a restriction in the fuel supply hardware.

Fuel Supply Hardware: The fuel is transferred from the fuel pump to the fuel filter then on to the fuel rail. This is accomplished by a combination of steel lines (2) and high pressure hoses (1).

The fuel pump delivers more volume than the injection system requires. The unused fuel is routed through a return line to the tank. The fuel is constantly circulated in this manner.

The fuel filter “traps” contaminants before they reach the fuel injectors and should be replaced at the specified interval. The arrow (on the filter) denotes the installation direction. The large filter size also serves as a volume reservoir for pressurized fuel (dampening fuel pump pulsations).

The fuel rail distributes an even supply of fuel to all of the injectors, and also serves as a volume reservoir.

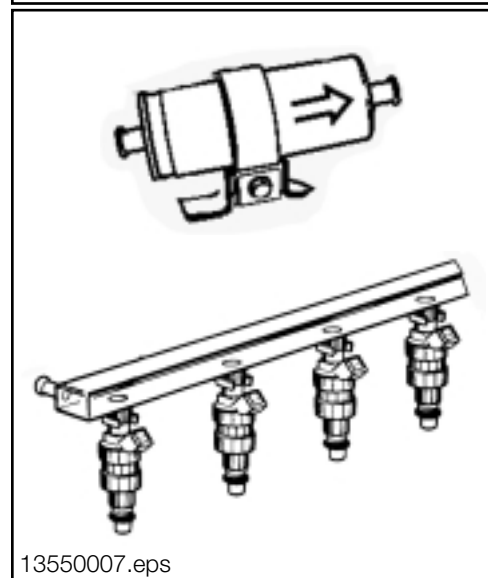
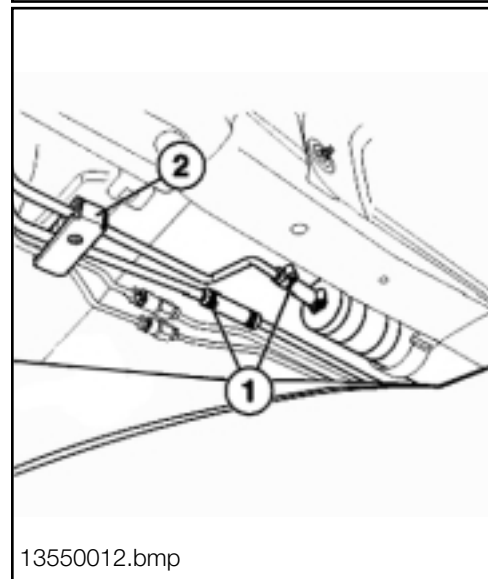
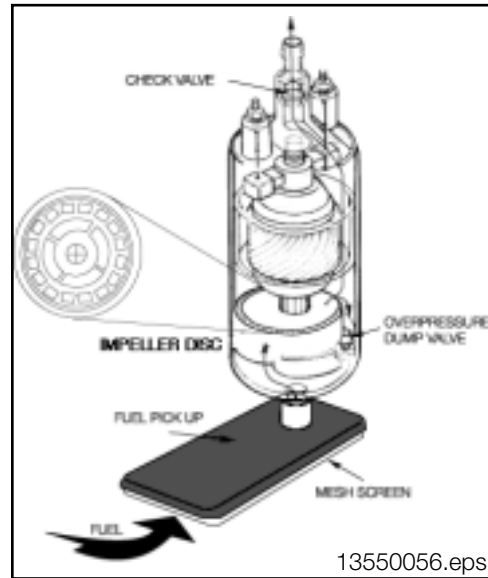

Fuel Pressure Regulator: The Fuel Pressure Regulator maintains a constant “pressure differential” for the fuel injectors.

The fuel pressure is set to 3.0 bar (+/- 0.2) by internal spring tension on the restriction valve.

The vacuum chamber is sealed off by a diaphragm which is connected by a hose to the intake manifold. Intake manifold vacuum regulates the fuel pressure by assisting to compress the spring (lowering fuel pressure).

When the restriction valve opens, unused fuel returns back to the fuel tank.

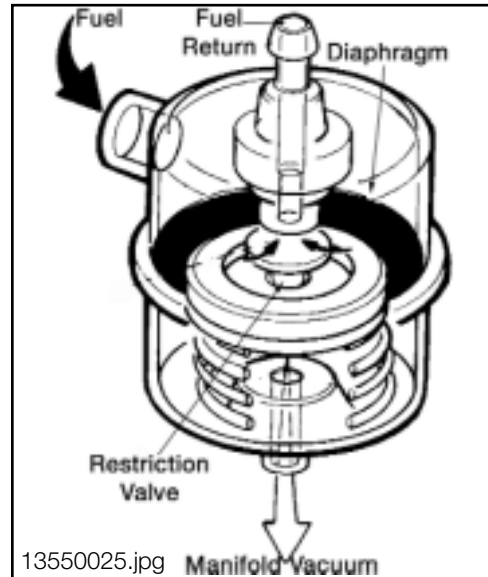

Examples of “pressure differential” are:

- At low to part throttle, intake manifold vacuum is available at the tip of the fuel injectors to enhance fuel “flow through”. Vacuum is also applied to the fuel pressure regulator vacuum chamber, causing the diaphragm to compress the spring which opens the restriction valve. This lowers the fuel pressure available to the fuel injectors.

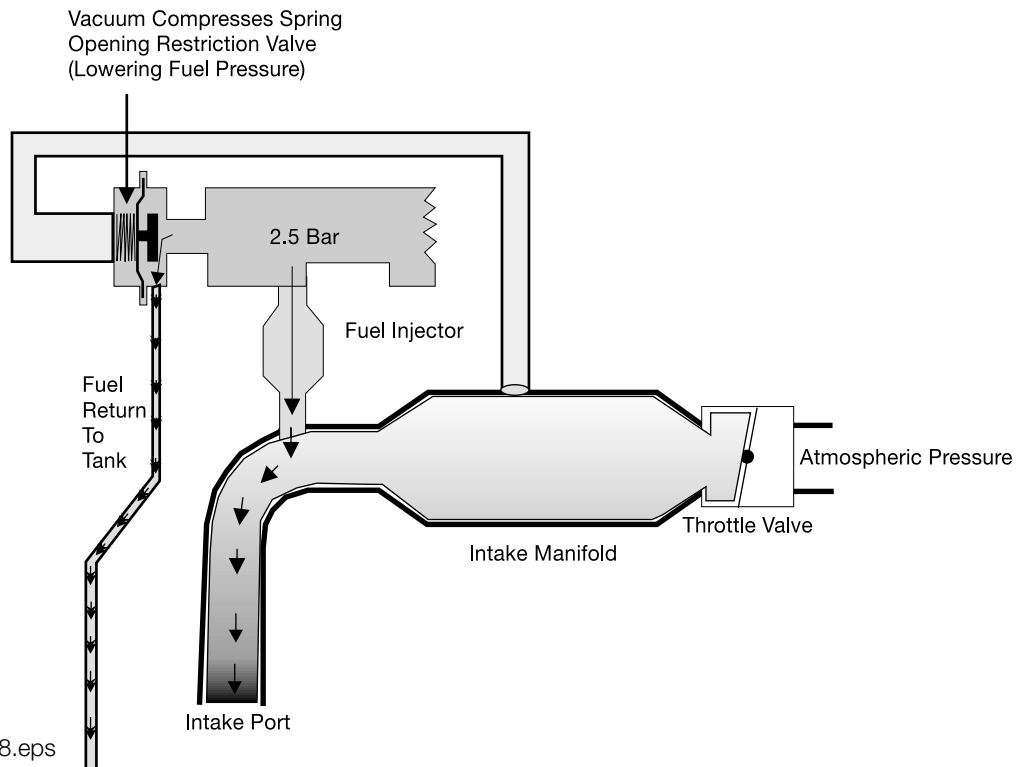

- Wide open throttle depletes intake manifold vacuum at the tip of the fuel injectors and in the fuel pressure regulator vacuum chamber. The spring closes the restriction valve to raise fuel pressure available to the fuel injectors. This maintains pressure differential (fuel flow through) for the fuel injectors.

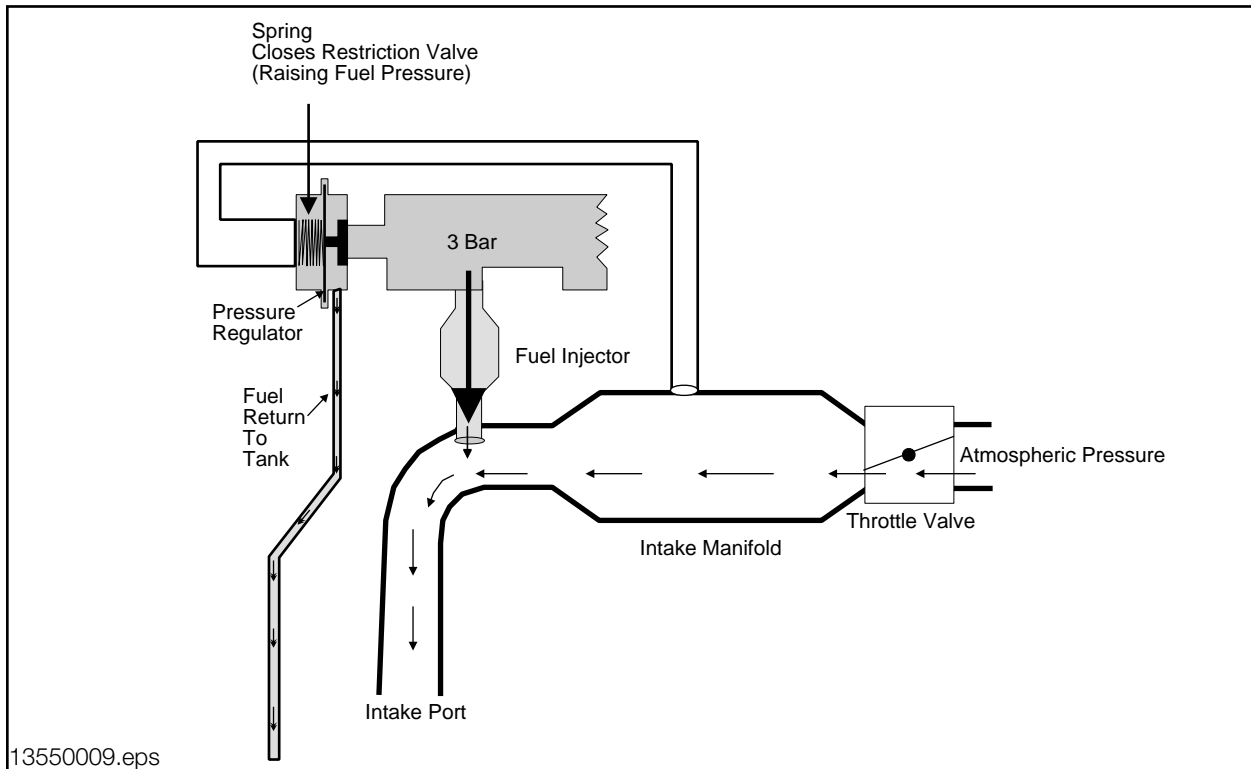

By maintaining constant Fuel Pressure Differential through vacuum sensing (engine load), the ECM can then regulate volume and mixture by the length of time the injectors are open (duration).

The Fuel Pressure Regulator is mounted on the fuel rail (arrow).

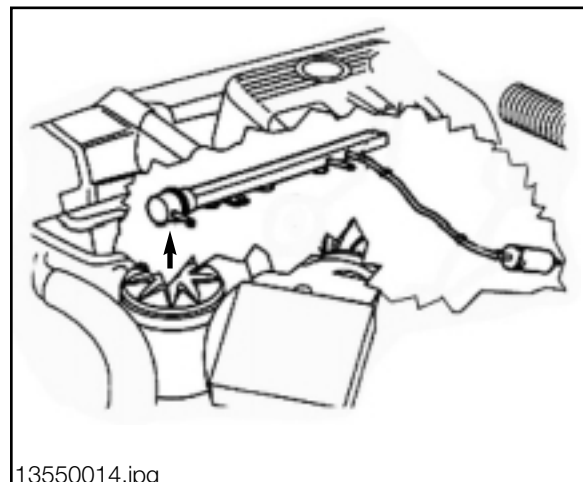

Bosch Fuel Injectors: The Fuel Injectors are electronically controlled solenoid valves that provide precise metered and atomized fuel into the engine intake ports. The Fuel Injector Valve consists of:

1.	Fuel Strainer
2.	Electrical Connector
3.	Solenoid Winding
4.	Closing Spring
5.	Solenoid Armature
6.	Needle Valve
7.	Pintle

Fuel is supplied from the fuel rail to the injector body. The fuel is channeled through the injector body to the needle valve and seat at the tip of the injector.

Without electrical current, the needle valve is sprung closed against the seat.

The Fuel Injectors receive voltage from the Engine Control Module Relay. The ECM activates current flow through the injector solenoid creating a magnetic field that pulls the needle “up” off of its seat.

The pressurized fuel flows through the opening and deflects off of the pintle.

The pintle (tip of the needle) is a cone shaped deflector that “fans out” the fuel spray into an angled pattern which helps to atomize the fuel.

When the ECM deactivates current flow, the needle valve is sprung closed against the seat and fuel flow through the injector is stopped.

The length of time that the ECM activates the Fuel Injectors is very brief, the duration is in milli-seconds (ms). This affects the amount of fuel volume flowing through the Fuel Injectors.

The ECM will vary the length of time (ms) to regulate the air/fuel ratio (mixture).

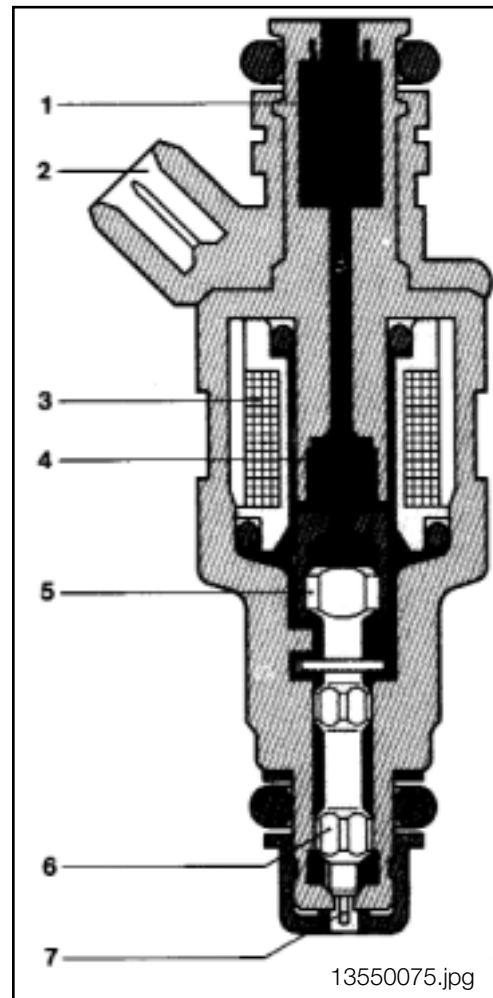

13550075.jpg

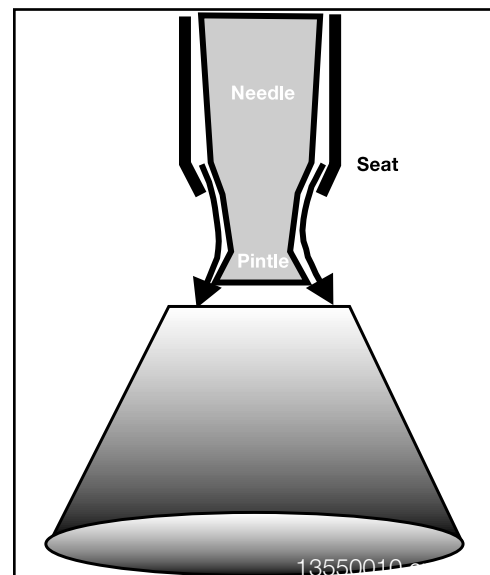

13550010.jpg

The Fuel Injectors are mounted in rubber “o-rings” between the fuel rail and the intake manifold to insulate them from heat and vibration. This insulation also reduces the injector noise from being transmitted through the engine compartment. The Fuel Injectors are held to the fuel rail by securing clips (arrow).

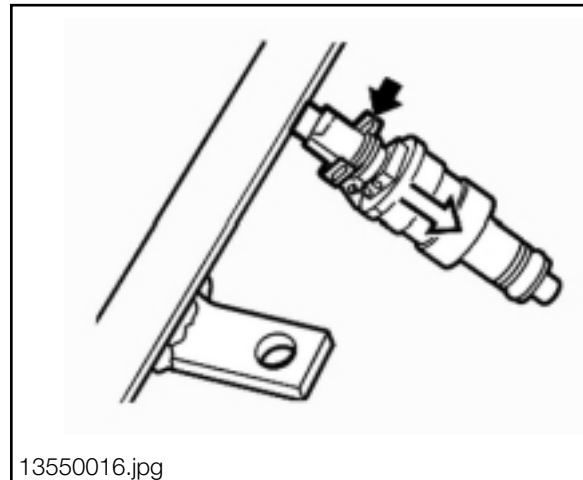

If a Fuel Injector is faulty (mechanical or electrical), it can produce the following complaints:

• “CHECK ENGINE” Light	• Misfire/Rough Idle (Leaking or Blocked)
• Excessive Tailpipe Smoke (leaking)	• Long Crank Time (leaking)
• Engine Hydrolock (leaking)	
• Oxygen Sensor/Mixture/Injector Related Fault Codes	

Air Shroud Injector: To comply with emission regulations, Air Shrouded Injectors have been fitted on the M42 engine since 1994 MY. There is an air gap between the inner and outer body of the fuel injector which allows additional metered air to be drawn in. This air disperses and mixes with the injected fuel which improves fuel atomization as it enters the combustion chamber thus lowering CO/HC emissions.

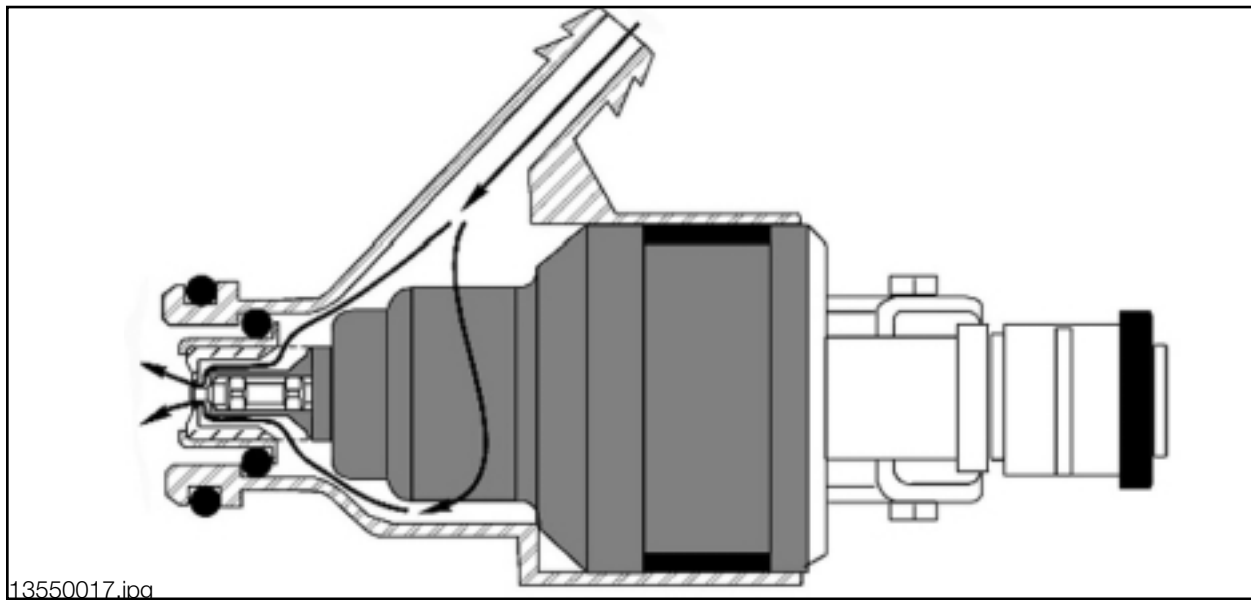

The Air Shrouded Injectors incorporate a hose fitting on the outer injector body which connects each injector via a rubber hose, to the molded Idle Speed Control Valve hose, under the intake manifold.

The metered air is taken from a fitting located in the intake bellows boot in front of the throttle valve (ported vacuum). The system is self regulating with greater air flow at idle and low load engine ranges (intake manifold vacuum drawing air in).

The Air Shrouded supply components are:

1.	Idle Speed Control Valve
2.	Connection to Intake Bellows Boot
3.	Connection to Intake Manifold
4.	Hoses for Air Shrouded Injectors

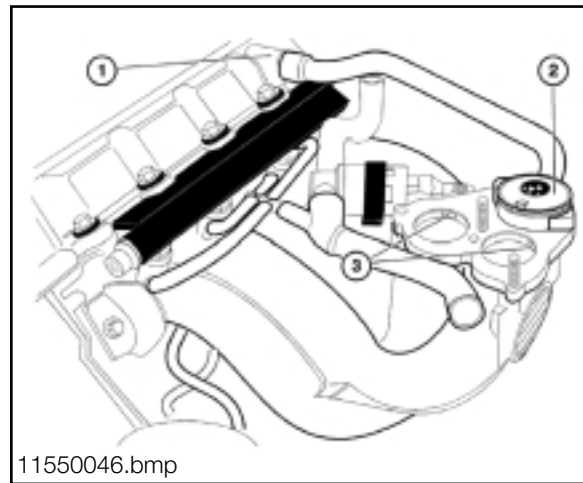

Crankshaft Position/RPM Sensor: This sensor provides the crankshaft position and engine speed (RPM) signal to the ECM for Fuel Pump and Injector operation. This is an inductive pulse type sensor. The ECM provides the power supply to this component.

The sensor scans an incremental impulse/gear wheel that has a total of 58 teeth and a gap of two missing teeth. The rotation of the impulse wheel generates an A/C voltage signal in the sensor where-by each tooth of the wheel produces one pulse. The ECM counts the pulses and determines engine rpm.

The gap of two missing teeth provides a reference point that the ECM recognizes as crankshaft position.

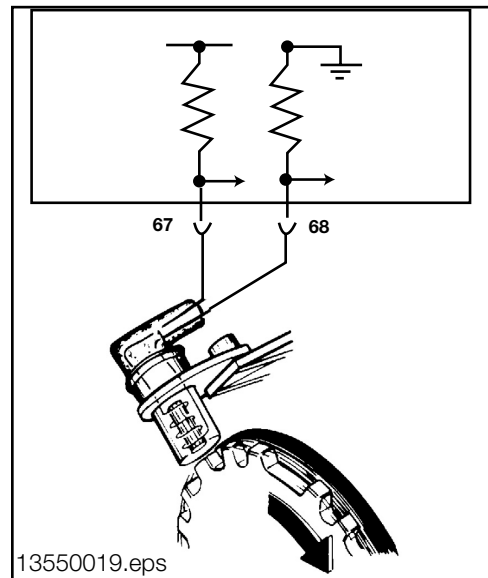

The impulse wheel is mounted behind the crankshaft pulley. The Sensor is mounted on the front timing cover (housing).

A fault with this input will produce the following complaints:

• No Start
• Intermittant Misfire / Driveability
• Engine Stalling

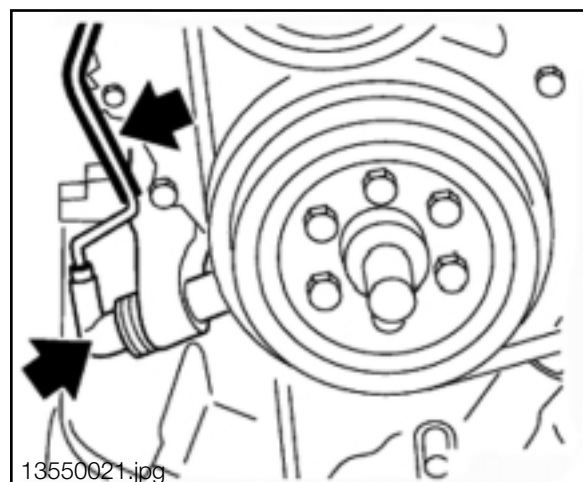

Camshaft Position Sensor (Cylinder Identification): The cylinder ID sensor (inductive pulse) input allows the ECM to determine camshaft position in relation to crankshaft position. It is used by the ECM to establish the firing order for the direct ignition system and the semi-sequential fuel injection timing.

The sensor scans a tooth mounted on the intake camshaft drive gear (mounted in the front of the cylinder head). The ECM provides the power supply for this component and monitors the A/C voltage generated when the tooth passes the sensor tip. This input provides one pulse per revolution of the camshaft.

This input is only checked by the ECM during “start up”. The camshaft position is referenced to the crankshaft position, and is not monitored until the next engine start up.

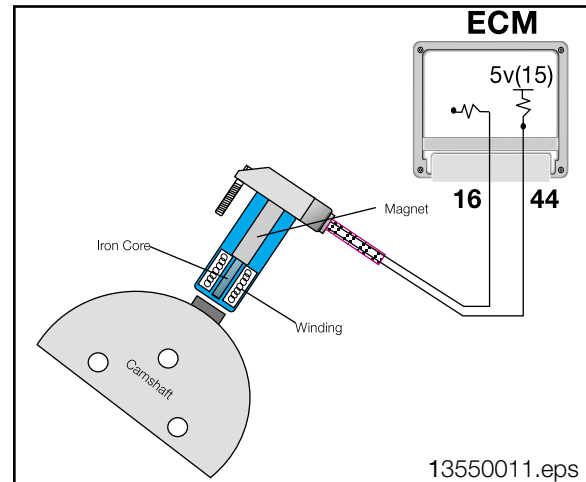

If the ECM detects a fault with the Cylinder ID Sensor, the “CHECK ENGINE” Light will be illuminated and the system will still operate based on the Crankshaft Position/RPM Sensor. Upon a restart, a slight change in driveability could occur because the ECM will activate Parallel Fuel Injection, all of the injectors will be activated at the same time.

Engine Coolant Temperature: The Engine Coolant Temperature is provided to the ECM from a Negative Temperature Coefficient (NTC) type sensor. The ECM determines the correct fuel mixture and base ignition timing required for the engine temperature.

The sensor decreases in resistance as the temperature rises and vice versa.

The ECM monitors an applied voltage to the sensor (5v). This voltage will vary (0-5v) as coolant temperature changes the resistance value.

This sensor is located in the coolant jacket of the cylinder head (1).

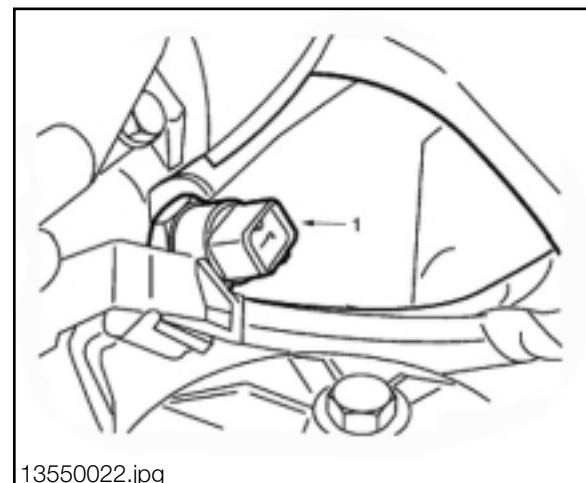

If the Coolant Temperature Sensor input is faulty, the “CHECK ENGINE” Light will be illuminated and the ECM will assume a substitute value (80° C) to maintain engine operation.

Throttle Position Sensor: The potentiometer is monitored by the ECM for throttle angle position and rate of movement. For details about the sensor, refer to the Air Management section.

As the throttle is opened, the ECM will increase the volume of fuel injected into the engine. As the throttle plate is closed, the ECM activates fuel shut off if the rpm is above idle speed (coasting).

If the Throttle Position input is defective, a fault code will be set and the “CHECK ENGINE” Light will illuminate. The ECM will maintain fuel injection operation based on the Air Flow Volume Sensor and the Crankshaft Position/RPM Sensor.

Air Flow Volume Sensor: This potentiometer sends a signal to the ECM representing the measured amount of intake air volume. This input is used by the ECM to determine the amount of fuel to be injected for correct air/fuel ratio. For details about the sensor, refer to the Air Management section.

If this input is defective, a fault code will be set and the “CHECK ENGINE” Light will illuminate. The ECM will maintain fuel injection operation based on the Throttle Position Sensor and Crankshaft Position/RPM Sensor.

Air Temperature: This signal allows the ECM to make a calculation of air density. The sensor is located in front of the measuring flap. For details about the sensor, refer to the Air Management section.

The varying voltage input from the NTC sensor indicates the larger proportion of oxygen found in cold air, as compared to less oxygen found in warmer air. The ECM will adjust the amount of injected fuel because the quality of combustion depends on oxygen sensing ratio.

If this input is defective, a fault code will be set and the “CHECK ENGINE” Light will illuminate.

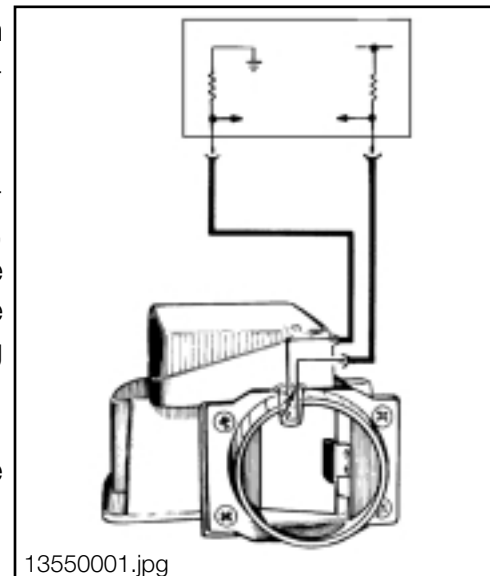
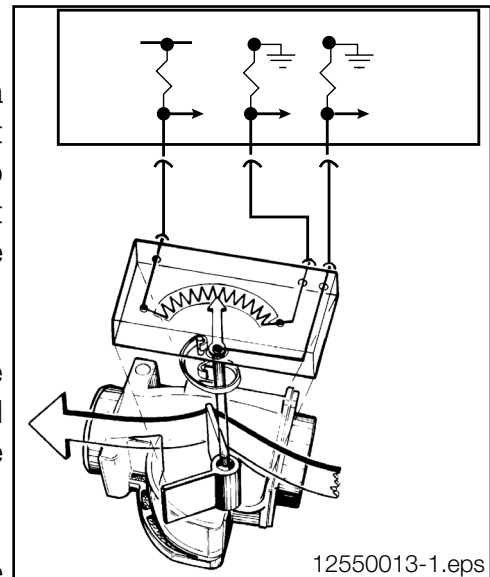
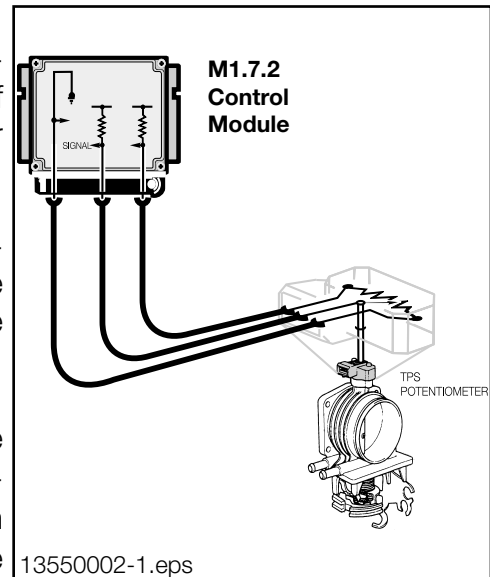

Principle of Operation

Fuel Management delivers fuel from the tank to the intake ports of the engine. To accomplish this, **fuel supply** must be available to the fuel injectors. Then the fuel must be **injected** in the precise amount and at the correct time. The ECM does not directly monitor fuel supply, although it does control fuel supply. **The Fuel Pump** supplies fuel when it receives operating voltage from the Engine Control Module Relay supplying the Fuel Pump Relay. The ECM controls and monitors **fuel injection**.

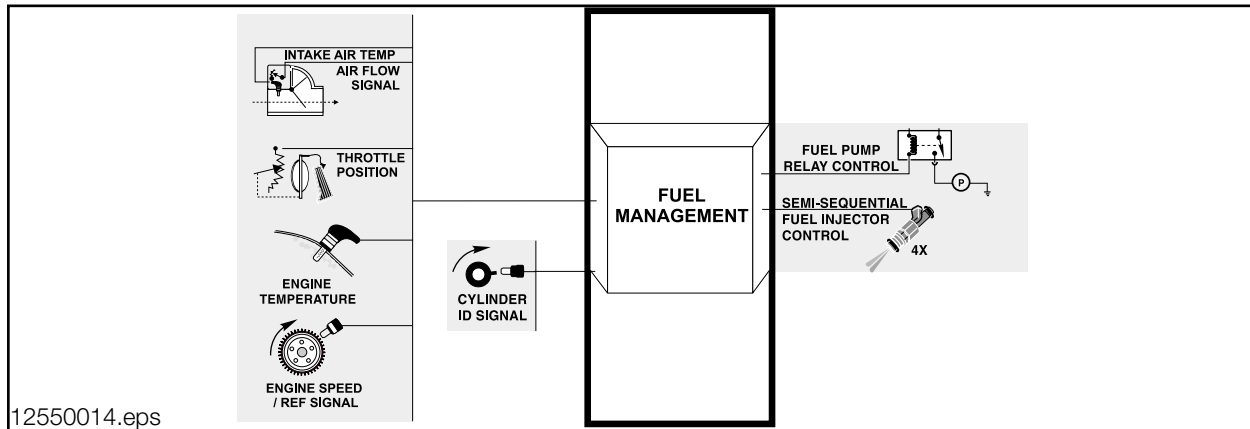

The Fuel Pump will be activated when the ignition (KL15) is switched “on” and the ECM supplies a ground circuit to activate the Fuel Pump Relay. The Fuel Pump Relay supplies operating power to the in-tank mounted fuel pump. This is a momentary activation to “pressurize” (prime) the fuel system.

The ECM then requires an engine RPM signal from the Crankshaft Position/RPM Sensor to maintain continuous Fuel Pump Relay activation.

If the engine RPM signal is not present, the ECM will deactivate the Fuel Pump Relay.

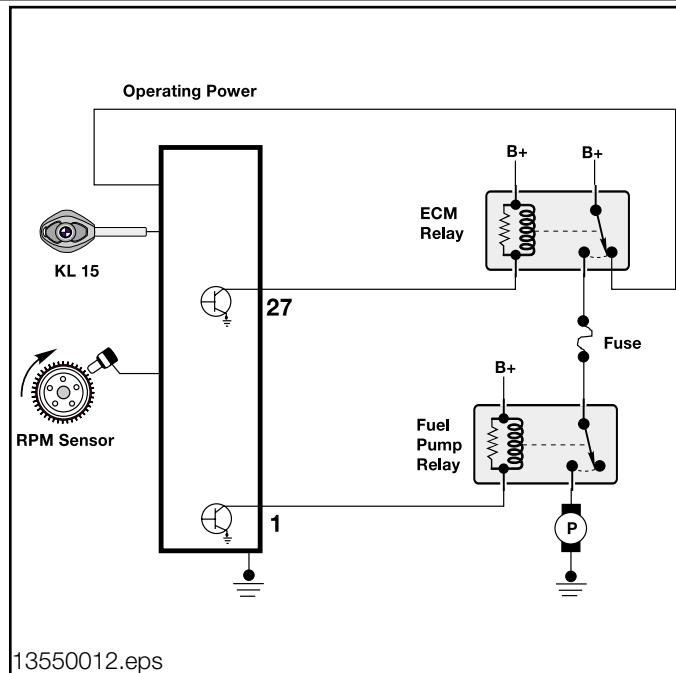

The Fuel Injectors will be opened by the ECM to inject pressurized fuel into the intake ports. The Fuel Injectors receive voltage from the Engine Control Module Relay. The ECM controls the opening by activating the ground circuit for the Solenoid Windings. The ECM will vary the duration (in milli-seconds) of “opening” time to regulate the air/fuel ratio.

The ECM has two Final Stage output transistors that switch ground to the four injector solenoids. The Injector “triggering” is first established from the Crankshaft Position/RPM Sensor.

The ECM is programmed to activate the Final Stage output transistors once for every revolution of the crankshaft (Parallel Injection). The ECM calculates the total milli-second time to open the injectors and cuts that value in half.

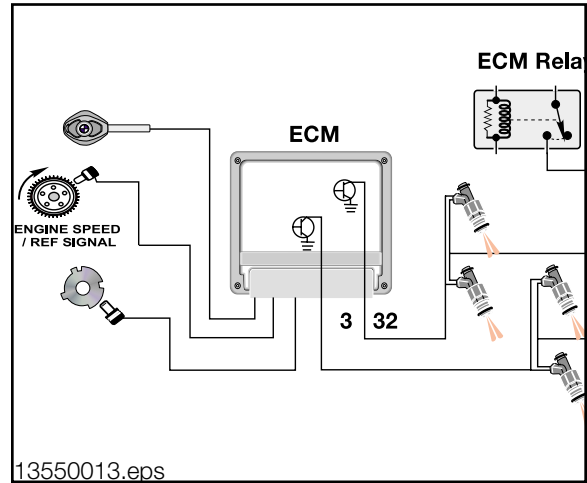

The injectors are all opened at the same time (in parallel) for every complete crankshaft revolution. This delivers half of the fuel charge at each injection so that the engine receives the full fuel charge during a complete working cycle. This process enhances fuel atomization during start up.

During start up, the ECM recognizes the Camshaft Position (Cylinder ID) input. It then switches the injection to Semi-Sequential. This process “times” the injection closer to the intake valve opening for increased efficiency.

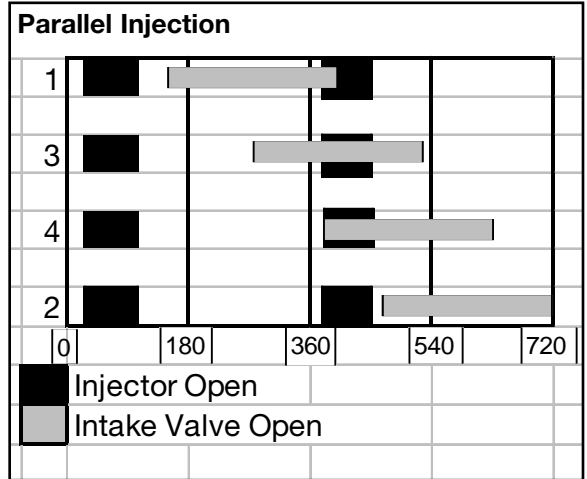

When activated, each group (grouped in pairs) delivers the full fuel charge at separate times for each engine working cycle.

The Camshaft Position input is only checked by the ECM during start up. The camshaft position is referenced to the crankshaft position, and is not monitored until the next engine start up. Therefore, if this input is lost when the engine is already running, there will be no effect. There will only be an effect if this input is missing when the engine is started. For this condition, the ECM will continue operating the injectors in Parallel.

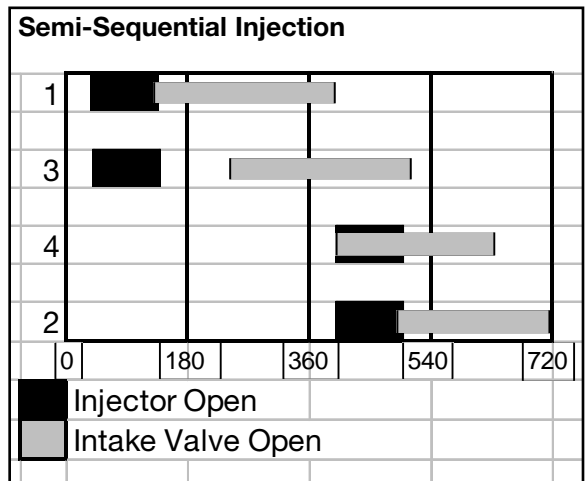

The Injector “open” Time to maintain engine operation after it has been started is determined by the ECM (programming). The ECM will calculate the engine “load” based on a combination of the following inputs:

- **Battery Voltage**
- **Throttle Position**
- **Air Flow Volume**
- **Air Temperature**
- **Crankshaft Position/RPM**
- **Crankshaft Position (Cylinder ID)**
- **Engine Coolant**
- **Oxygen Sensor (Detail in Emissions)**

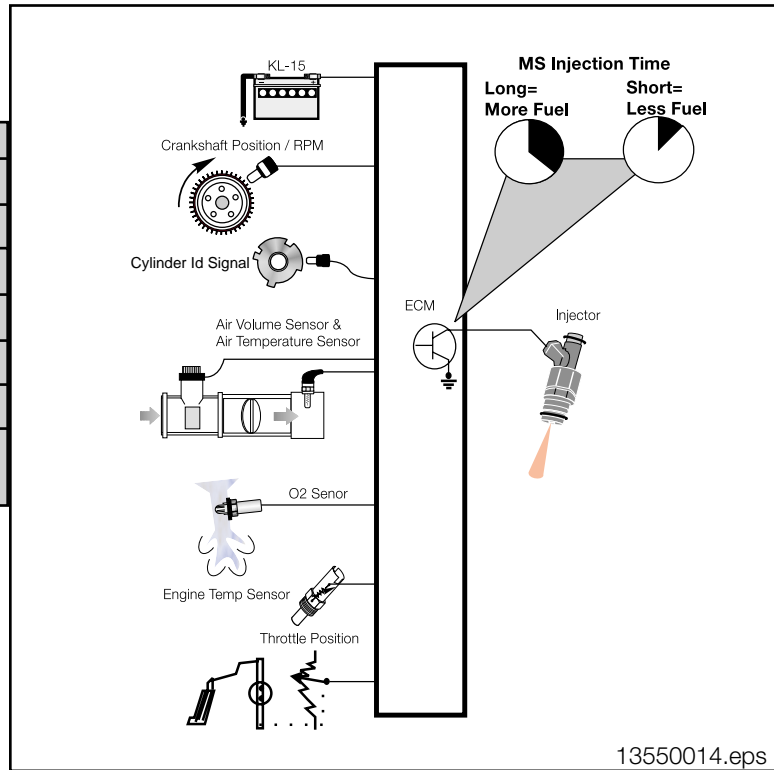

The injection ms value will be regulated based on battery voltage. When cranking, the voltage is low and the ECM will increase the ms value to compensate for injector “lag time”. When the engine is running and the battery voltage is higher, the ECM will decrease the injection ms value due to faster injector reaction time.

Cold starting requires additional fuel to compensate for poor mixture and the loss of fuel as it condenses onto cold intake ports, valves and cylinder walls. The cold start fuel quantity is determined by the ECM based on the Engine Coolant Temperature Sensor input during start up.

During cranking, additional fuel is injected (in Parallel) for the first few crankshaft revolutions. After the first few crankshaft revolutions, the injected quantity is metered down as the engine comes up to speed. When the engine speed approaches idle rpm, the ECM recognizes the Camshaft Position and switches to Semi-Sequential injection.

When the engine is cold, optimum fuel metering is not possible due to poor air/fuel mixing and an enriched mixture is required. The Coolant Temperature input allows the ECM to adjust the injection ms value to compensate during warm up and minimize the the injected fuel at engine operating temperature.

When the engine is at idle, minimum injection is required. Additional fuel will be added if the ECM observes low engine rpm and increasing throttle/air volume inputs (acceleration enrichment). As the throttle is opened, the ECM monitors acceleration and rate of movement. The ECM will increase the volume of fuel injected into the engine by increasing the injection ms value. The “full throttle” position indicates maximum acceleration and the ECM will add more fuel (full load enrichment).

As the throttle is closed, the ECM decreases the injection ms value (fuel shut off) if the rpm is above idle speed (coasting). This feature decreases fuel consumption and lowers emissions. When the engine rpm approaches idle speed, the injection ms value is increased (cut-in) to prevent the engine from stalling. The cut-in rpm is dependent upon the engine temperature and the rate of deceleration.

The Air Flow Volume signal provides the measured amount of intake air volume. This input is used by the ECM to determine the amount of fuel to be injected to “balance” the air/fuel ratio.

The Air Temperature Signal allows the ECM to make a calculation of air density. The varying voltage input from the NTC sensor indicates the larger proportion of oxygen found in cold air, as compared to less oxygen found in warmer air. The ECM will adjust the amount of injected fuel because the quality of combustion depends on oxygen sensing ratio (details in Emissions).

The Crankshaft Position/RPM signals the ECM to start injection as well as providing information about the engine operation. This input is used in combination with other inputs to determine engine load which increases/decreases the injection ms value. Without this input, the ECM will not activate the injectors.

The Camshaft Position (Cylinder ID) affects the injection ms value (half= Parallel Injection or full= Semi-Sequential Injection) and the timing when it is injected to the engine. To accomplish this, the ECM contains two Final Stage output transistors that activate the injectors in two groups. The engine operates sufficiently on Parallel Injection, but more efficiently on Semi-Sequential Injection. If one of the circuits faulted, the engine can still operate on limited power from the remaining circuit.

Injection “Reduction” Time is required to control fuel economy, emissions, engine and vehicle speed limitation. The ECM will “trim” back or deactivate the fuel injection as necessary while maintaining optimum engine operation.

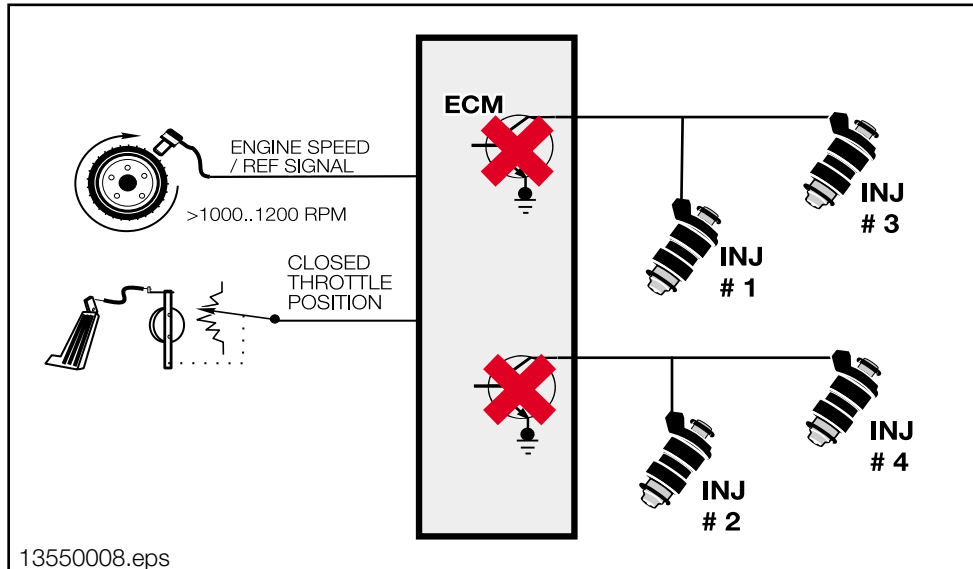

As the throttle is closed during deceleration, the ECM decreases the injection ms value (fuel shut off) if the rpm is above idle speed (coasting). This feature decreases fuel consumption and lowers emissions.

When the engine rpm approaches idle speed, the injection ms value is increased (cut-in) to prevent the engine from stalling. The cut-in rpm is dependent upon the engine temperature and the rate of deceleration. This function can be observed as displayed on the Fuel Economy (MPG) gage.

The ECM will deactivate the injectors to control maximum engine rpm (regardless of vehicle speed). When the engine speed reaches 6500 rpm, the injectors will be deactivated to protect the engine from over-rev. As the engine speed drops below 6500 rpm, injector activation will be resumed. **This feature does not protect the engine from a forced over-rev such as improperly downshifting a manual transmission equipped vehicle (driver error).**

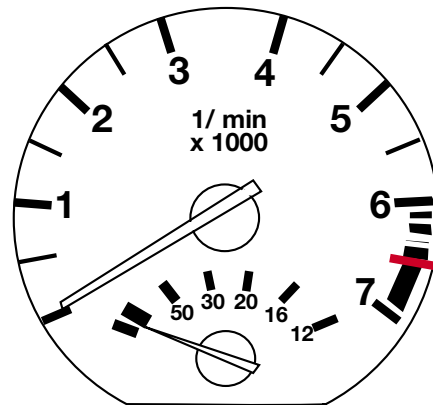

12550023.eps

Maximum vehicle speed is limited by the ECM reducing the injection ms value (regardless of engine rpm). This limitation is based on the vehicle dimensions, specifications and installed tires (speed rating).

The ECM will also protect the Catalytic Converter by deactivating the injectors.

If the ECM detects a fault in the primary ignition system, it can selectively deactivate the Final Stage output transistor for that cylinder.

The injector will not open, preventing unburned fuel from entering the exhaust system.

On the M1.7.2 system, there are two injectors per circuit resulting in deactivation of both. This will limit engine power, but protect the Catalytic Converter.

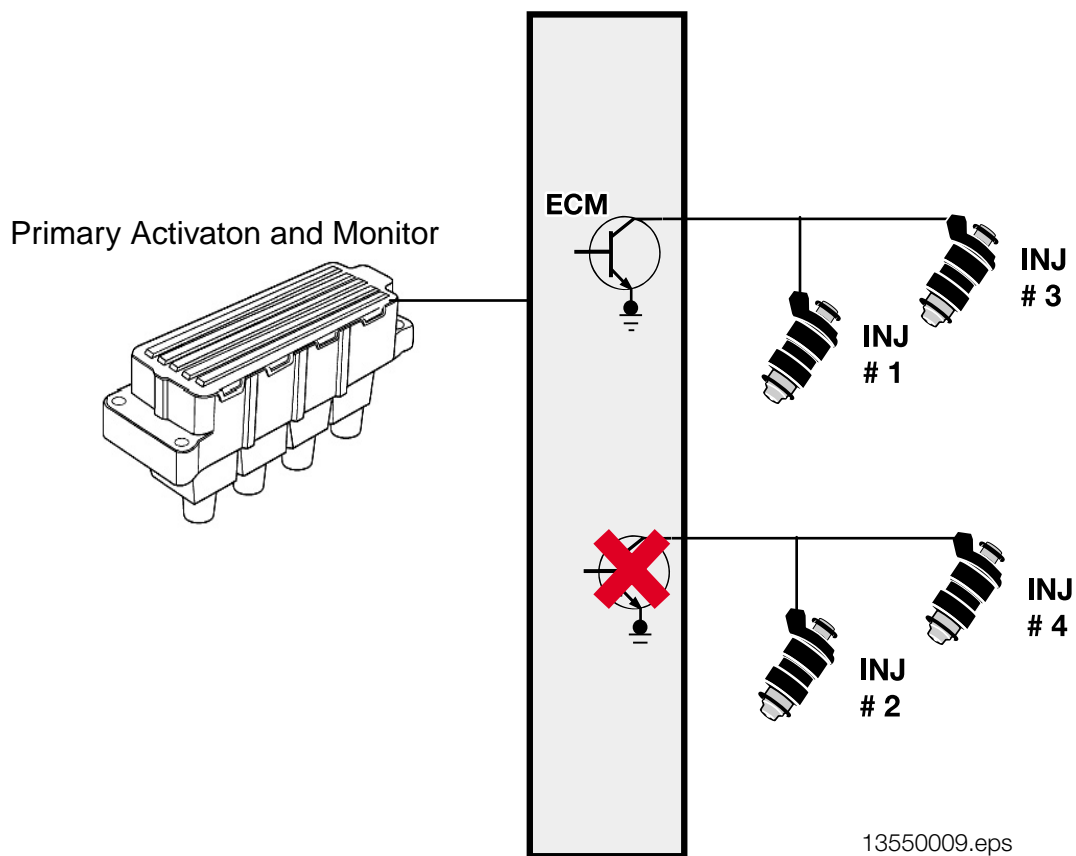

Workshop Hints

Before any service work is performed on any fuel system related component, always adhere to the following:

• Observe relevant safety legislation pertaining to your area.
• Ensure adequate ventilation.
• Use exhaust extraction system where applicable (alleviate fumes).
• DO NOT OPERATE THE FUEL PUMP unless it is properly installed in the fuel tank and is submerged in the fuel (fuel lubricates the pump).
• DO NOT SMOKE while performing fuel system repairs.
• Always wear adequate protective clothing including eye protection.
• Use caution when working around a HOT engine compartment.
• During fuel system repairs that involve “sealing rings”, always replace them with new copper sealing rings only.
• BMW does not recommend any UNAUTHORIZED MODIFICATIONS to the fuel system. The fuel system are designed to comply with strict federal safety and emissions regulations. In the concern of product liability, it is unauthorized to sell or perform modifications to customer vehicles, particularly in safety related areas.
• Always consult the REPAIR INSTRUCTIONS on the specific model you are working on before attempting a repair.

Fuel

Fuel quality should always be considered when diagnosing a driveability complaint. The type of fuel, proper AKI rating, impurities and moisture are not factored by the ECM.

Please refer to the Owner’s Manual and following Service Information Bulletins regarding fuel:

• Gasoline Fuel Quality S.I. #13 01 88 (1564)	• Gasoline Additive S.I. #13 04 88 (1591)
---	---

Fuel Supply

The fuel supply hardware should be visually inspected for damage that can affect pick-up, transfer, pressure and return.

Please refer to the Repair Instructions and the following Service Information Bulletins details on fuel supply hardware:

• Engine Compartment Return Fuel Hose S.I. #13 03 92 (3589)
• Feed Fuel Hose Recall Campaign S.I. #13 04 92 (3657)
• Refueling S.I. #16 01 92 (3553)
• Fuel System Modifications S.I. #16 01 81

Fuel Pump and Sending Unit Access

All BMW vehicles have access plates to service the fuel pump and sending units without removing the fuel tank.

The access plates are located under the rear seat.

The “saddle” type fuel tank (under rear seat) has two access plates.

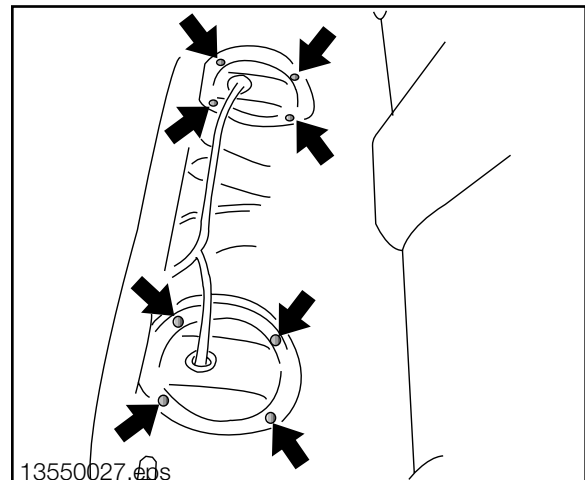

The passenger side allows access to the fuel pump/sending unit.

The driver side allows access to the sending unit.

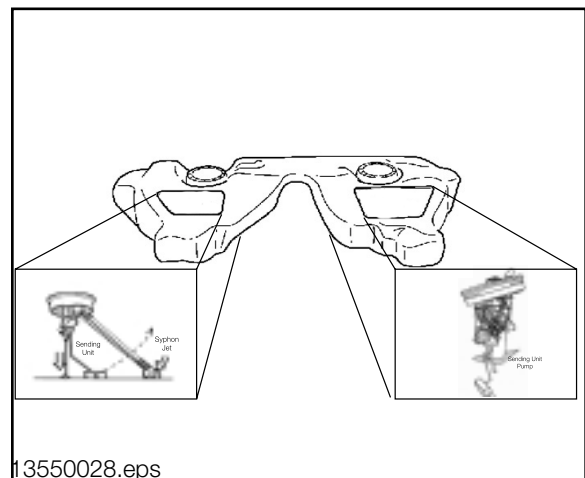

Draining the Fuel Tank

In order to remove the fuel tank it must be drained first to avoid fuel spills and handling excessive weight. In some cases depending on the fuel tank dimensions (vehicle specific), it is also necessary to drain the fuel tank to replace the sending units and/or fuel pump.

CAUTION: In some vehicles, the sending units/fuel pump is mounted lower than the top of the fuel tank. A fuel spill will be encountered if the fuel is not drained.

NOTE: Consult the BMW Service Workshop Equipment for the proper evacuation equipment.

The saddle type tank requires an additional step to drain the fuel from the driver side. The evacuation equipment should be attached to the tank compensating hose (arrow) to drain out the remaining fuel.

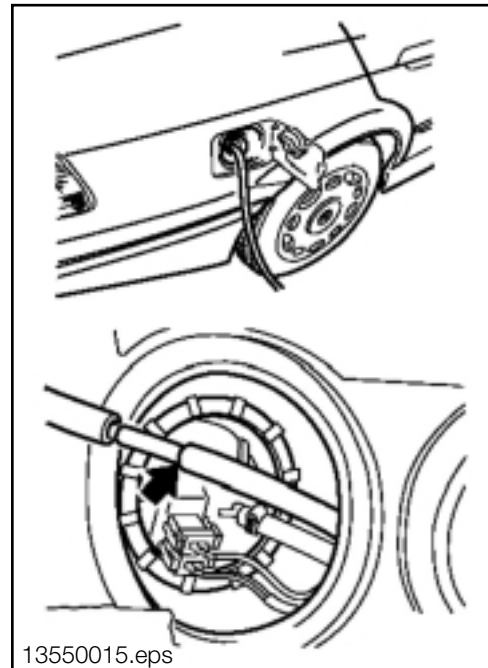

Fuel Pump/Pressure Regulator - Testing

The fuel pump should be tested for delivery pressure and volume. **Caution** when disconnecting fuel hoses because there is the possibility of residual fuel pressure! Install the fuel pressure gage between the fuel filter and and pressure regulator.

Remove the fuel pump relay (see relay testing in the power supply section) and connect the Relay Bypass Switch to pin 87b and 30 of the relay socket. This will activate the fuel pump without running the engine.

If the 3 bar fuel pressure is not achieved or bleed off is more than 0.5 bar, refer to **13 31 of the Repair instructions** for further diagnosis. The Fuel Hose Clamp Tool can be used to isolate bleed off from the pump (non-return check valve) or the pressure regulator (restriction valve). Also verify power supply to the fuel pump.

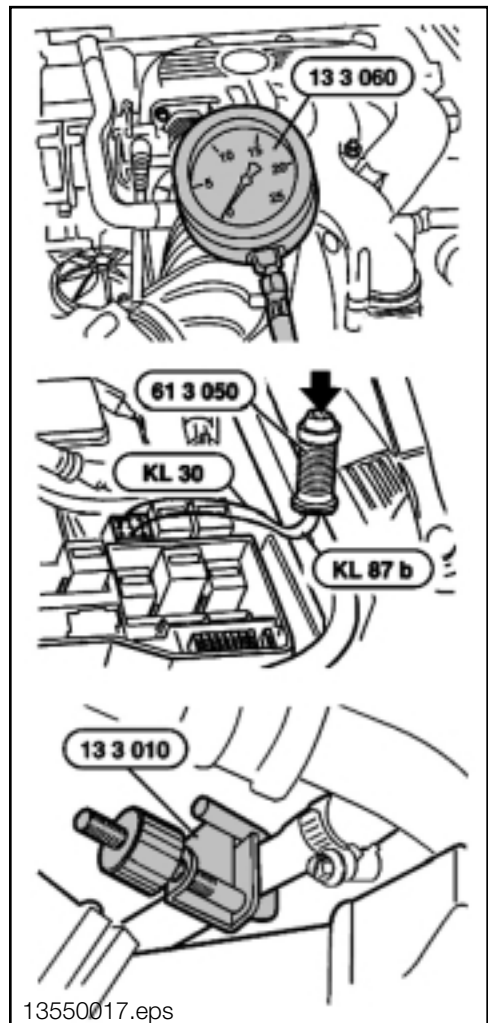

Fuel volume must be tested to verify:

- **Fuel Pump Output**
- **Restriction are not present in the pump pickup lines/hoses and fuel filter**

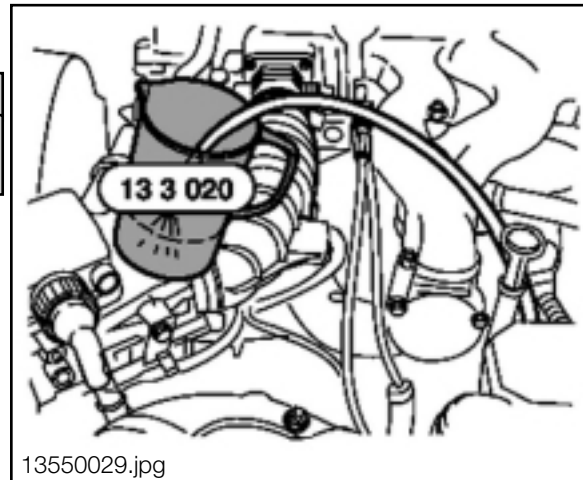

13550029.jpg

Fuel Injectors

When inspecting the fuel injectors, consider the following:

- **O-rings should be replaced, lubricated with vaseline or SAE 90 gear oil for installation.**
- **Verify the code number**
- **Plastic spacer washer is not damaged**
- **Color code of nozzle hosing**
- **Color code injector housing**

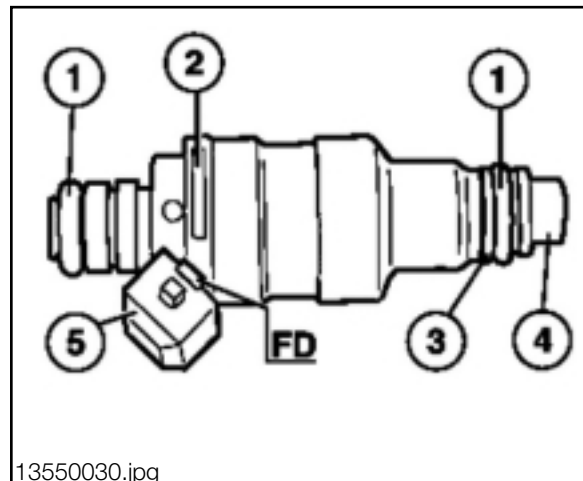

13550030.jpg

Fuel injectors can leak which bleeds off fuel pressure and increases emissions. The injectors can be tested using the Fuel Injector Leakage Tester.

The fuel injectors can be cleaned, refer to Service Information Bulletin S.I. #04 07 86.

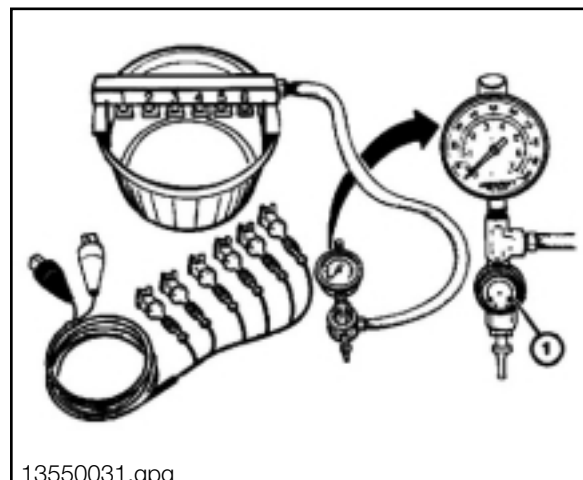

13550031.jpg

The Fuel Injectors should also be tested using the DIS/MoDIC for:

- Resistance (15 - 17 ohms)
- Power Supply
- Status Display - Fuel Injection Signal (approximate 3.5 - 5 ms)
- ECM Final Stage transistor activation. This test function is found under the Oscilloscope Preset list - "Ti Injection Signal". Install the 88 pin adapter, Diagnostic cable, MFK 2 negative lead to ECM ground and MFK 2 positive lead to the ground activation circuit for the injector. This test is performed with the engine running.

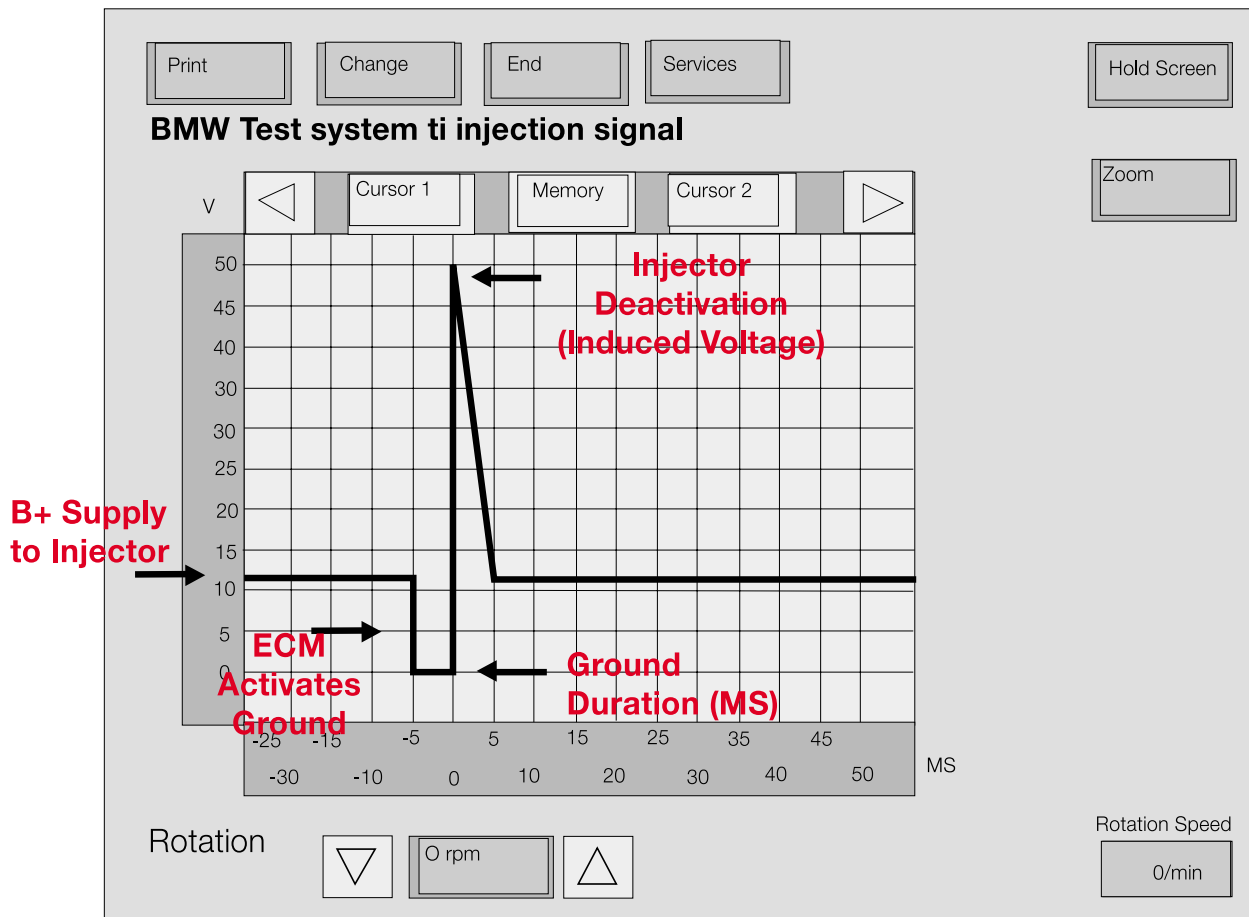
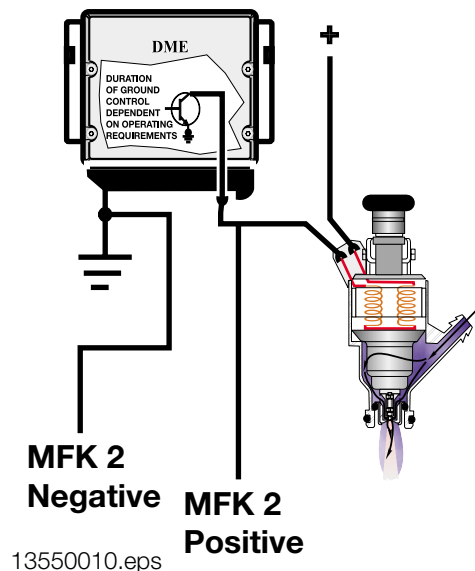

Crankshaft Position/RPM Sensor

This sensor should be tested using the DIS/MoDIC for:

- Resistance (540 ohms +/- 10%) • Power Supply • AC Voltage • Status Display
- Oscilloscope Display found under Preset list - "Rotation Speed Sensor Signal"

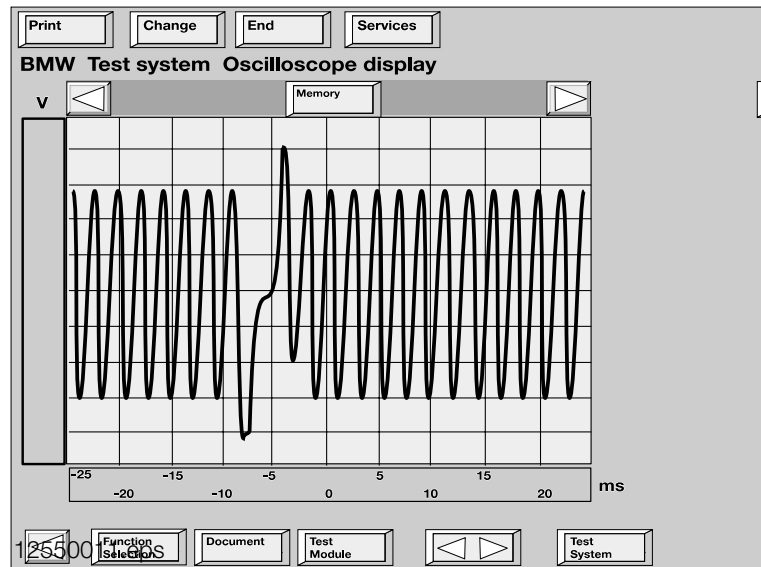
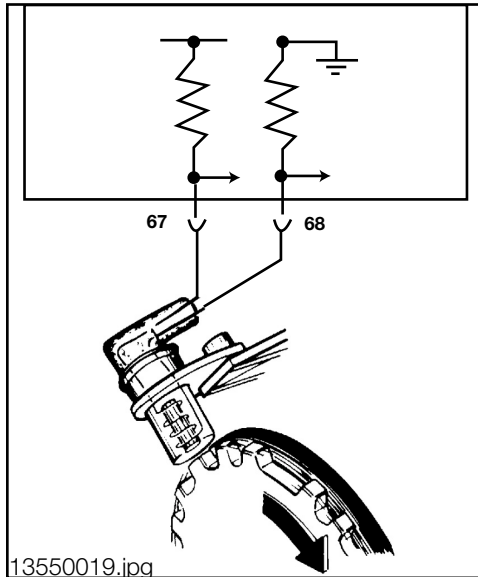

Camshaft Position Sensor (Cylinder ID)

This sensor should be tested using the DIS / MoDic for

- Resistance (0.1 - 1 ohm) • Power Supply • AC Voltage • Status Display - "ON"
- Oscilloscope Display found under Preset list - "Rotation Speed Sensor Signal"

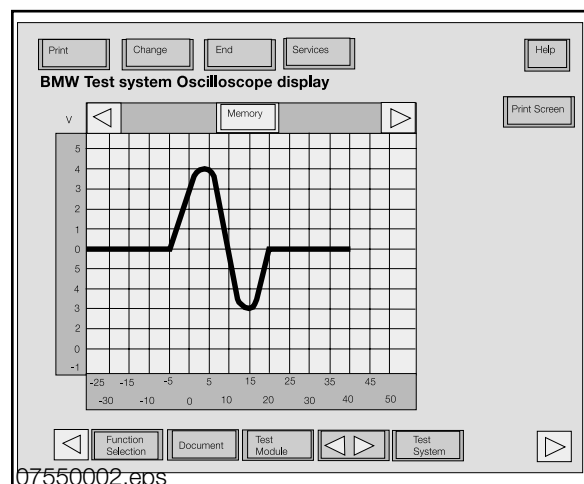
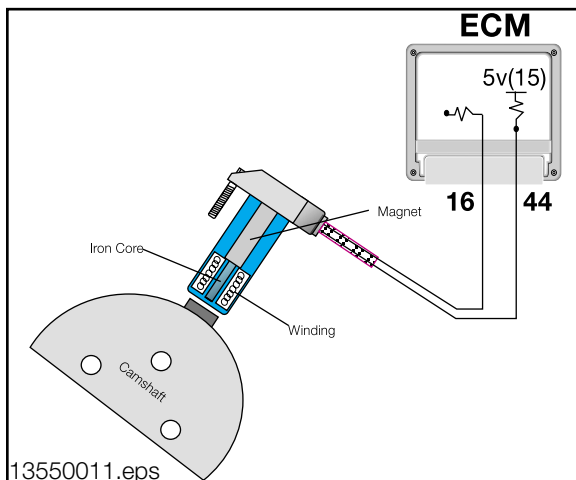

Engine Coolant Temperature

NTC sensors decrease in resistance as the temperature rises and vice versa. The ECM monitors the sensor voltage which varies as temperature changes the resistance value. For example, as temperature rises:

- Resistance through the sensor decreases
- Voltage drop of the sensor decreases
- Input signal voltage also decreases (5-0v)

The Sensor should be tested using:

- DIS/Modic Status page degrees C (dependent on engine temperature).
- DIS/Modic Multimeter
20° C 2.2 - 2.7 K ohms
80° C 0.3 - 0.36 K ohms

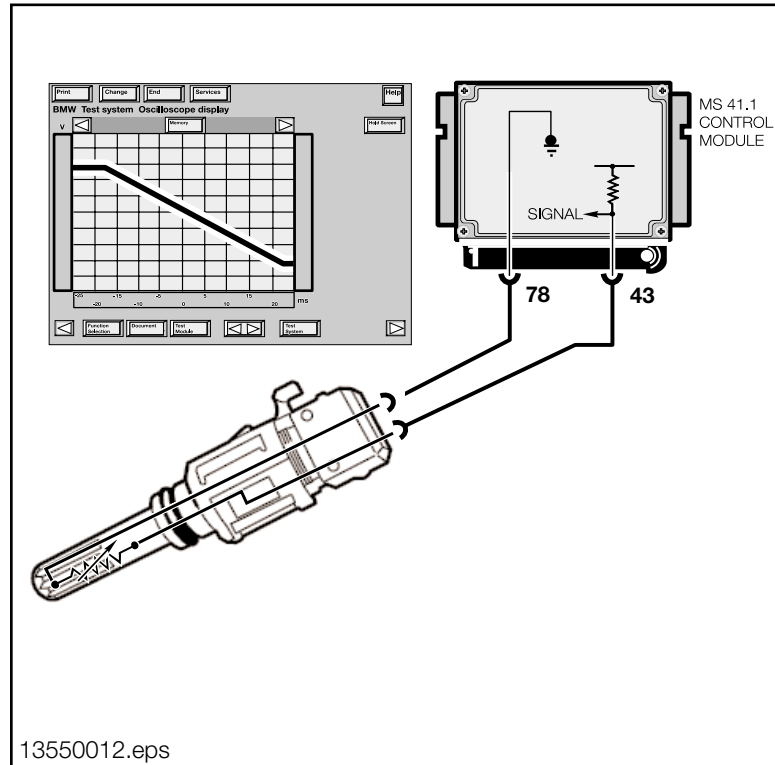

Tools and Equipment

The DIS/Modic as well as a reputable hand held multimeter can be used when testing inputs/components.

It is best to make the checks at the ECM connection, this method includes testing the wiring harness.

The correct Universal Adapter for the M1.7.2 application should be used (#88 88 6 614 410). This will ensure the pin connectors and the harness will not be damaged.

The interior of this Universal Adapter is shielded, therefore it is vital that the ground cable is connected to the vehicle chassis whenever the adapter is used.

The adapter uses a Printed Circuit board inside keeping the capacitive and inductive load to a minimum.

When installing the Universal Adapter to the ECM (located below the windshield on the passenger side of the engine compartment), make sure the ignition is switched off.

The Fuel Hose Clamp Tool (#13 3 010) can be used for isolating pressure faults. In addition, fuel loss can be reduced when changing the fuel filter while loosening clamps (1 and 2).

The Relay Bypass Switch (#61 3 050) must be used especially **when fuel vapors are present!** The switch eliminates the risk of electrical arcing.

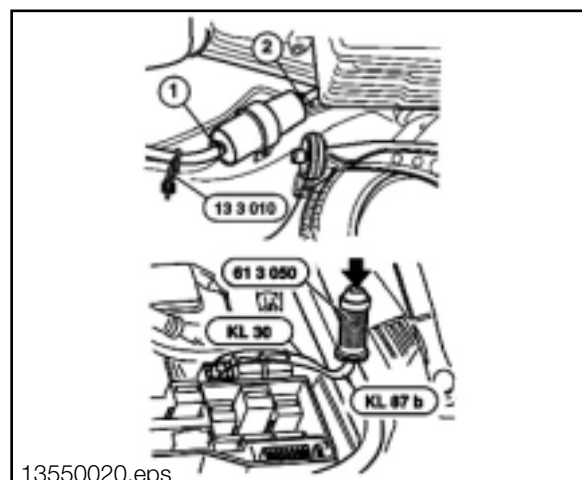
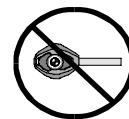
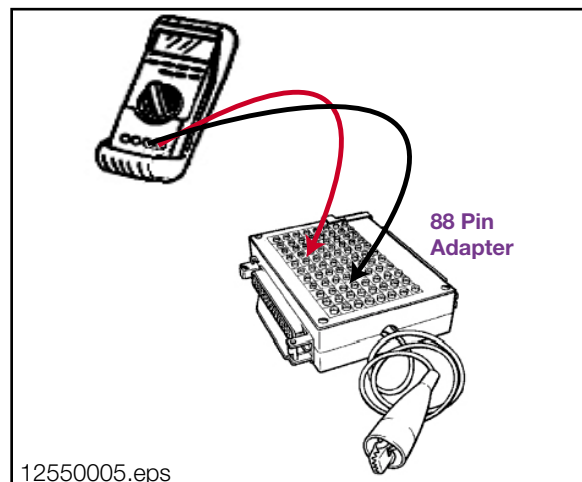
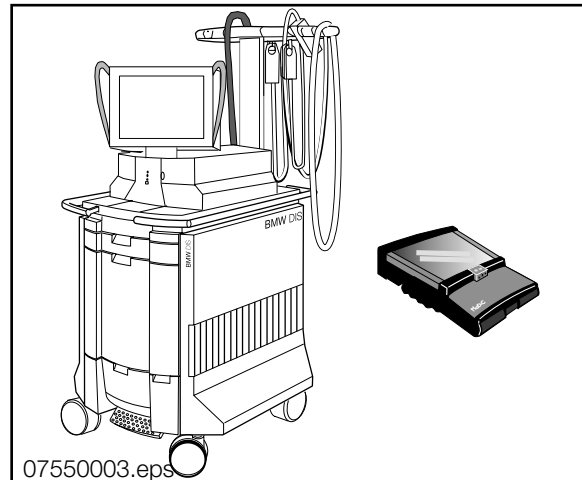

When testing fuel pressure, the hand held fuel pressure gage (#13 3 060) can be used.

Caution: Residual fuel pressure may be present!

The DIS is equipped with a pressure measuring function, found in Measurement testing. The following adapters (Special Tool numbers) will be necessary:

• #13 6 051 • #13 6 055 • #13 6 057

These adapters install “in line” in the fuel pressure hose.

For vehicles equipped with “quick-release” couplings, install special tool (#13 5 270) between the fuel filter (1) and pressure supply hose (2). This tool will couple to the DIS Pressure Adapter (3).

Later fuel rails are equipped with a threaded adapter fitting (1).

This threaded adapter fitting allows Adapter #13 5 220 to be threaded on to the fuel rail and coupled to the DIS Pressure Adapter.

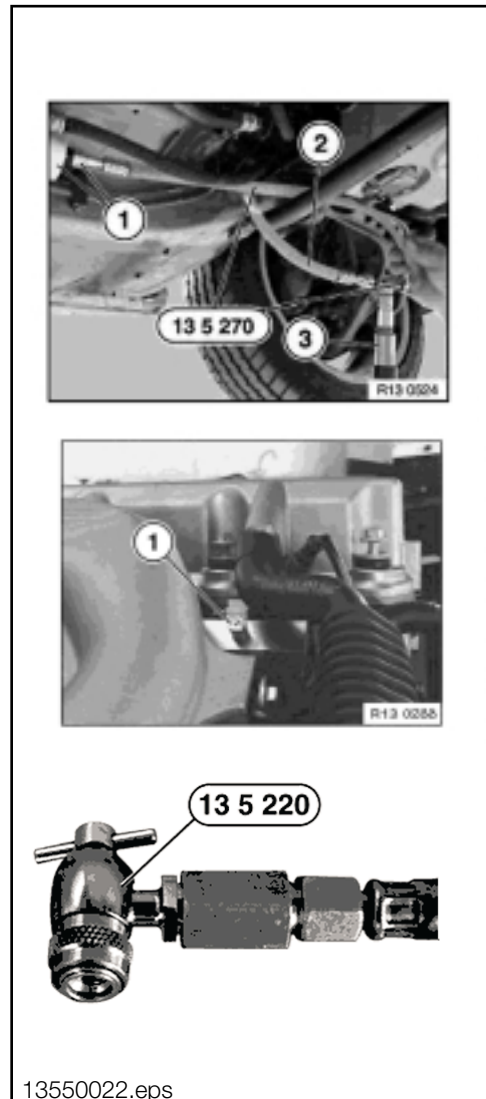
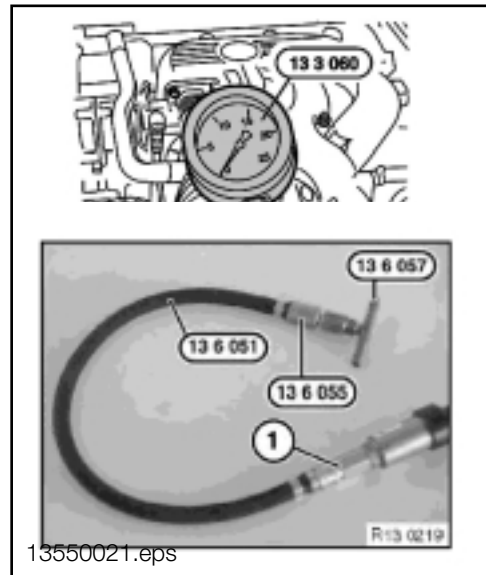

When testing the fuel injectors for leakage, use Special Tool #88 88 5 000 362. Leak testing the fuel injectors is one of the diagnostic steps listed in "Long Cranking Times" S.I. #13 08 90 (3096). This tool pressurizes the injectors with air and the injector tips are submerged in water. If air bubbles are present, this indicates the leaking injector(s).

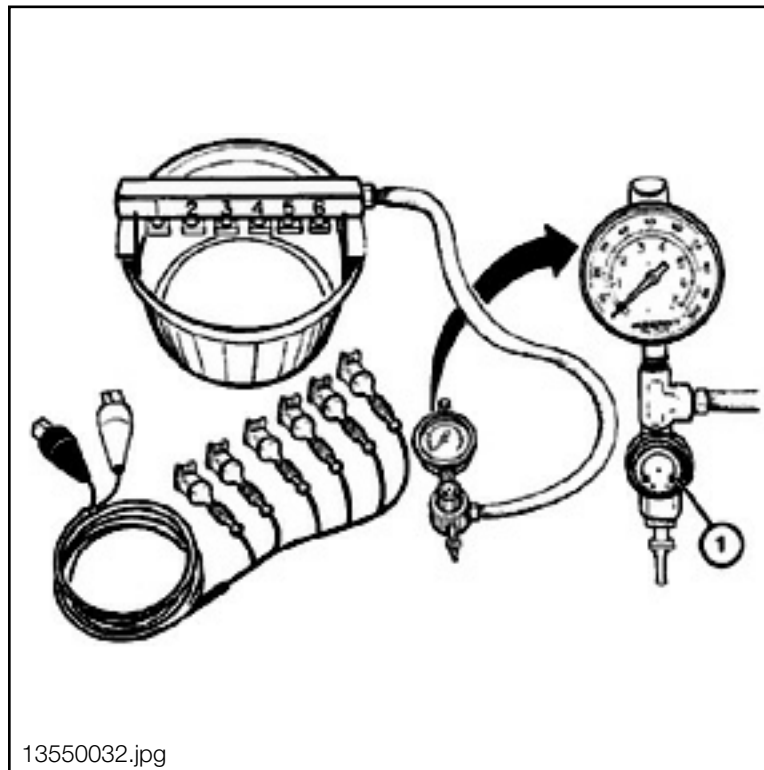

Ignition Management

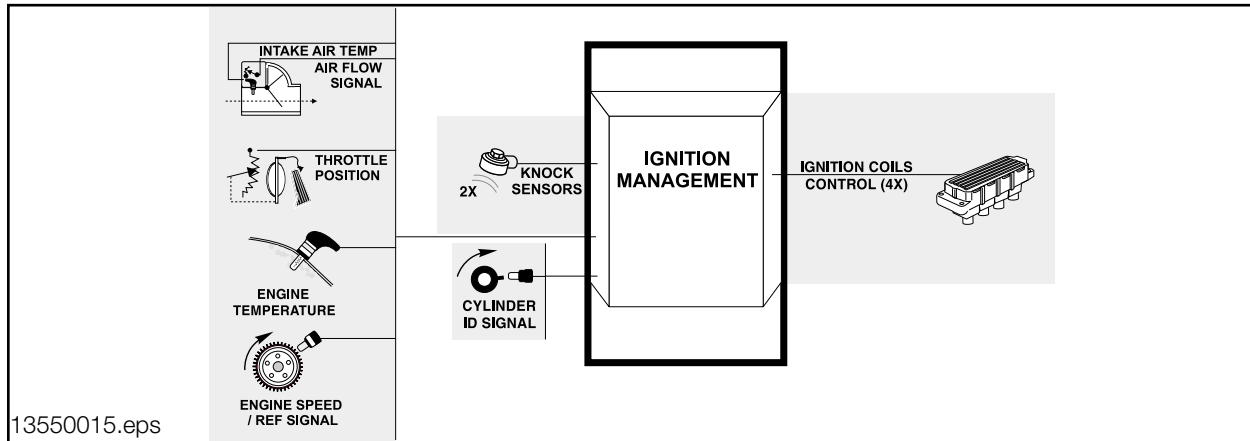

Ignition Coils: The high voltage supply required to ignite the mixture in the combustion chambers is determined by the stored energy in the ignition coils. The stored energy contributes to the ignition duration, ignition current and rate of high voltage increase. The Coil circuit including primary and secondary components consists of:

- | |
|---|
| 1. Coil Assembly |
| <ul style="list-style-type: none"> • Primary Winding • Secondary Winding (with diode) |
| 2. Resistor (Boot Connector) |
| 3. Spark Plug |
| 4. ECM Final Stage Transistor |
| 5. Secondary Coil Ground |

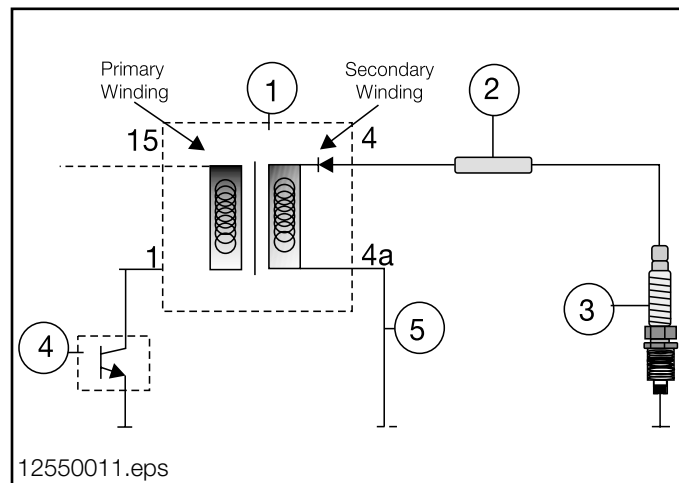

The Coil Assembly contains two copper windings insulated from each other. One winding is the primary winding, formed by a few turns of thick wire. The secondary winding is formed by a great many turns of thin wire.

The primary winding receives battery voltage from the ignition switch (Terminal 15). The ECM provides a ground path for the primary coil (Terminal 1) by activating a Final Stage transistor. The length of time that current flows through the primary winding is the “dwell” which allows the coil to “saturate” or build up a magnetic field. After this storage process, the ECM will interrupt the primary circuit at the point of ignition by deactivating the Final Stage transistor. The magnetic field built up within the primary winding collapses and induces the ignition voltage in the secondary winding.

The voltage generated in the secondary winding is capable of 30,000 volts (30 kV). The high voltage is discharged (Terminal 4) through the secondary ignition cable and resistor (boot connector) to the spark plug.

The primary and secondary windings are uncoupled, therefore, the secondary winding requires a ground supply (Terminal 4a).

The secondary winding connects to a cascade diode which suppresses any unwanted induced voltages as the primary circuit is switched on and off. This permits a clean, high voltage discharge from the secondary winding.

There is an individual ignition circuit and coil for each cylinder on the M1.7.2 system

The four ignition coils are combined into a single component (coil pack) located on the right front strut tower.

The ignition primary circuits are fault monitored by the ECM. If a fault is present, the "CHECK ENGINE" Light will illuminate and the ECM will deactivate the corresponding fuel injector for that cylinder and engine operation will still be possible.

Ignition Leads: The secondary ignition cables (high tension leads) direct the high voltage from the ignition coils to the spark plugs. The ignition lead assembly consists of:

- **Connector Socket**
- **Ignition Cable**
- **Resistive Adaptive Boot**

The ignition cables are routed into a covered cable tray located on the top of the cylinder head, which contains the boot connector removal tool (arrow).

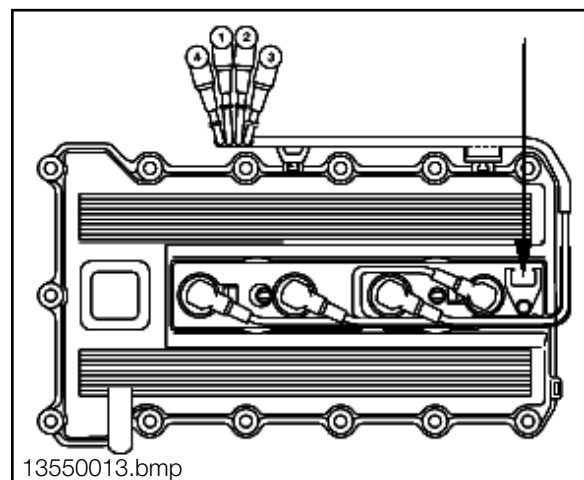
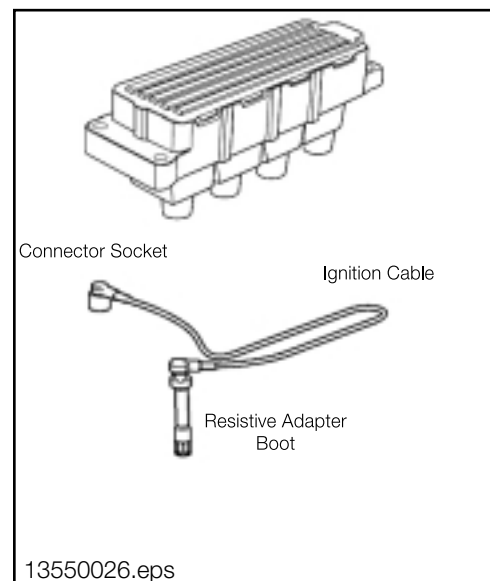
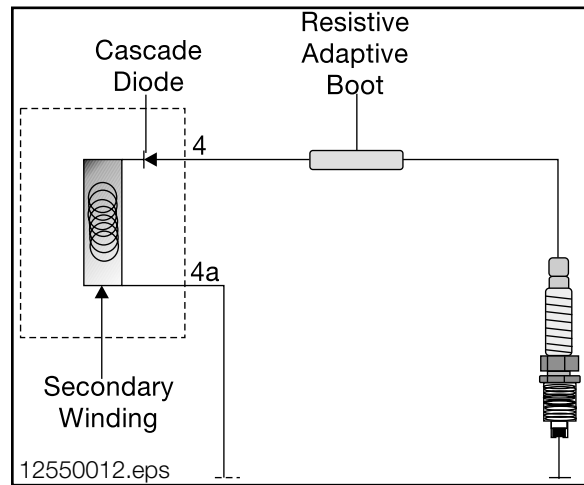

Spark Plugs: The spark plugs introduce the ignition energy into the combustion chamber. The high voltage “arcs” across the air gap in the spark plug from the positive electrode to the negative electrode. This creates a spark which ignites the combustable air/fuel mixture.

The spark plugs are located in the center of the combustion area (on the top of the cylinder head) which is the most suitable point for igniting the compressed air/fuel mixture.

The correct spark plugs (as seen above right) for this system are:

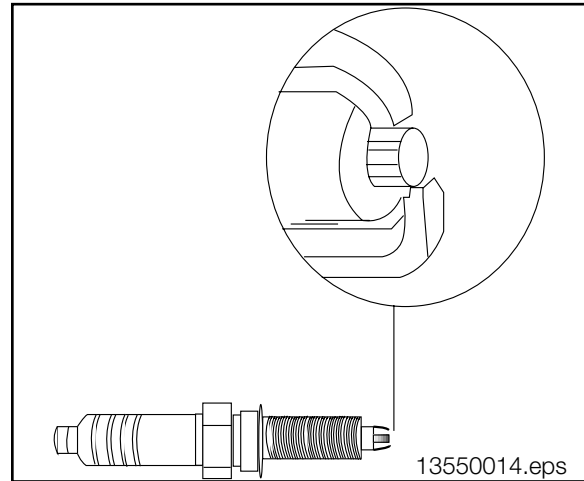

- | |
|--|
| • Bosch F7LDCR (dual electrode, non-adjustable gap) |
| • NGK BKR7EK (dual electrode, non-adjustable gap) |

Note: The High Performance Platinum Spark Plugs are also approved for use.

Faults with the Ignition Output Components are not monitored by the ECM, with the exception of the primary ignition circuit. If there are faults with the igniton coil(s) output, igniton leads and/or spark plugs, the following complaints could be encountered:

- | |
|--|
| • “CHECK ENGINE” Light With Mixture Related Fault Codes |
| • Poor Engine Performance |
| • Engine Misfire |
| • No Start / Hard Starting |
| • Excessive Exhaust Emissions / Black Smoke |

The Ignition Output Components must be individually tested (see Workshop Hints)

Knock Sensors: are required to prevent detonation (pinging) from damaging the engine. The Knock Sensor is a piezoelectric conductor-sound microphone. The ECM will retard the ignition timing (cylinder selective) based on the input of these sensors. Detonation can occur due to:

• High Compression Ratio	• Maximum Timing Advance Curve
• Poor Quality Fuel (Octane Rating)	• High Intake Air and Engine Temperature
• High Level of Cylinder Filling	• Carbon Build-Up (Combustion Chamber)

The Knock Sensor consists of:

1. Shielded Wire
2. Cup Spring
3. Seismic Mass
4. Housing
5. Inner Sleeve
6. Piezo-Ceramic Element

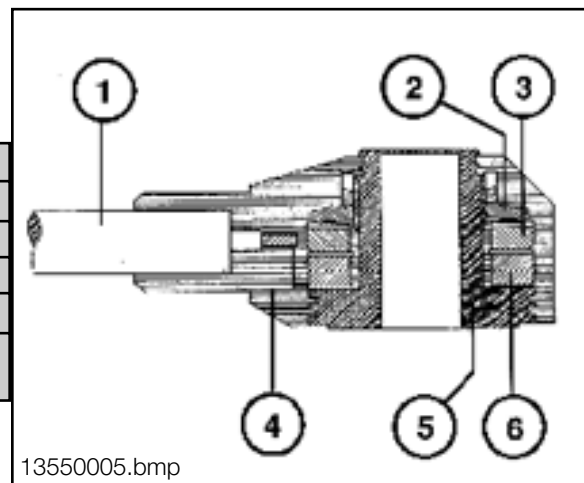

A piezo-ceramic ring is clamped between a seismic mass and the sensor body. When the seismic mass senses vibration (flexing), it exerts a force on the piezo-ceramic element. Opposed electrical charges build up on the upper and lower ceramic surfaces which generates a voltage signal. The acoustic vibrations are converted into electrical signals. These low voltage signals are transmitted to the ECM for processing.

There are two Knock Sensors bolted to the engine block (1) between cylinders 1 & 2 and (2) between cylinders 3 & 4. If the signal value exceeds the threshold, the ECM identifies the “knock” and retards the ignition timing for that cylinder.

If a fault is detected with the sensors, the ECM deactivates Knock Control. The “CHECK ENGINE” Light will be illuminated, the ignition timing will be set to a conservative basic setting and a fault will be stored.

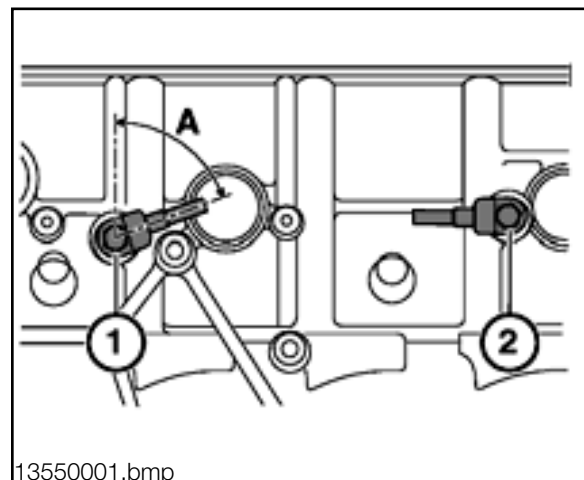

Crankshaft Position/RPM Sensor: This sensor provides the crankshaft position and engine speed (RPM) signal to the ECM for ignition activation and correct timing. For details about the sensor, refer to the Fuel Management section.

A fault with this input will produce the following complaints:

- | |
|--|
| • No Start |
| • Intermittant Misfire/Driveability |
| • Engine Stalling |

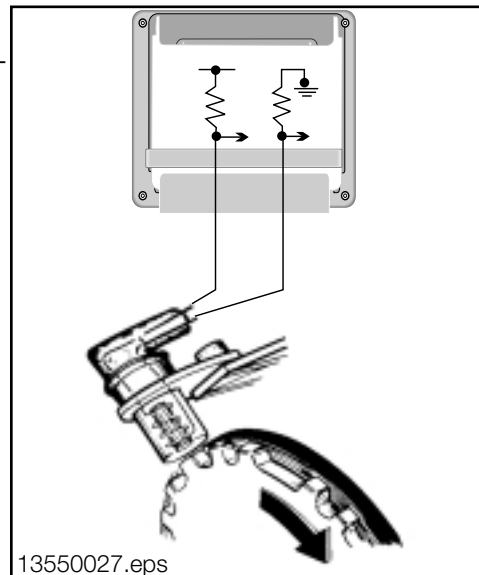

Camshaft Position Sensor (Cylinder Identification): The cylinder ID sensor (inductive pulse) input allows the ECM to determine camshaft position in relation to crankshaft position. It is used by the ECM to establish the “working cycle” of the engine for precise ignition timing. For details about the sensor, refer to the Fuel Management section.

If the ECM detects a fault with the Cylinder ID Sensor, the “CHECK ENGINE” Light will be illuminated and the system will still operate based on the Crankshaft Position/RPM Sensor.

Upon a restart, a slight change in driveability could occur because the ECM will activate “**double ignition**”. The ignition coils will be activated on both the compression and exhaust strokes to maintain engine operation.

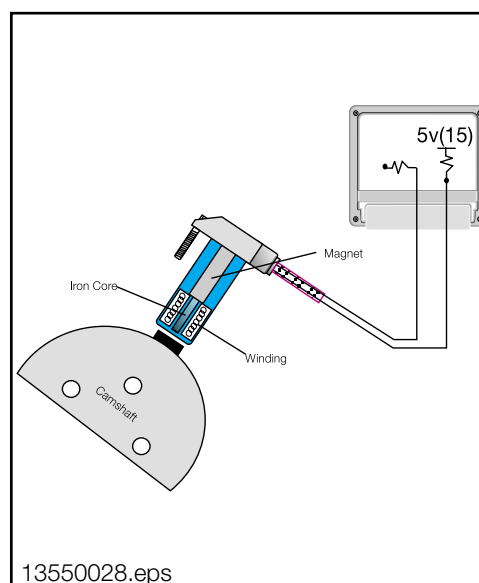

Engine Coolant Temperature: The ECM determines the correct ignition timing required for the engine temperature. For details about the sensor, refer to the Fuel Management section. This sensor is located in the coolant jacket of the cylinder head (1).

If the Coolant Temperature Sensor input is faulty, the “CHECK ENGINE” Light will be illuminated and the ECM will assume a substitute value (80° C) to maintain engine operation. The ignition timing will be set to a conservative basic setting.

Throttle Position Sensor: This sensor provides the ECM with throttle angle position and rate of movement. For details about the sensor, refer to the Air Management section.

As the throttle plate is opened, this requests acceleration and at what rate. The ECM will advance the ignition timing. The “full throttle” position indicates maximum acceleration to the ECM, the ignition will be advanced for maximum torque.

If the Throttle Position input is defective, a fault code will be set and the “Check Engine” Light will illuminate. The ECM will maintain engine operation based on the Air Flow Volume Sensor and the Engine Speed Sensor, and the ignition timing will be set to a conservative basic setting.

Air Flow Volume Sensor: This signal to the ECM represents the measured amount of intake air volume. This input is used by the ECM to determine the amount of ignition timing advance. For details about the sensor, refer to the Air Management section.

If this input is defective, a fault code will be set and the “Check Engine” Light will illuminate. The ECM will maintain engine operation based on the Throttle Position Sensor and Engine Speed Sensor, and the ignition timing will be set to a conservative basic setting.

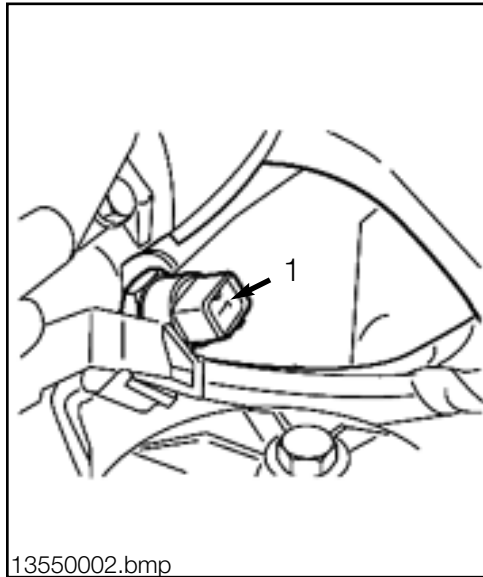

13550002.bmp

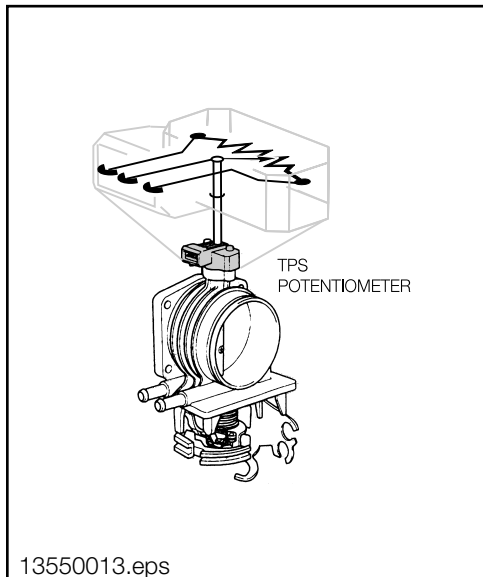

13550013.eps

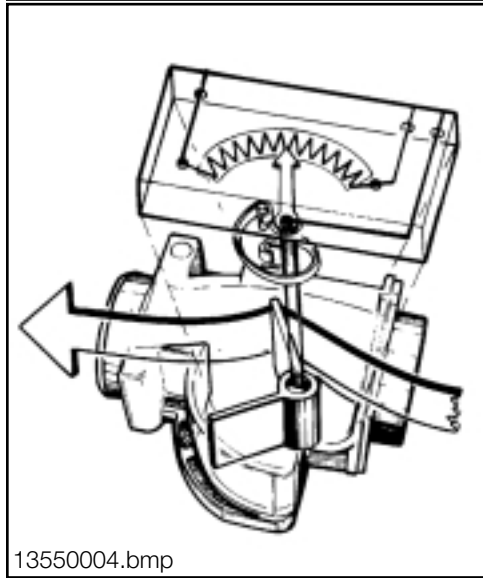

13550004.bmp

Air Temperature: This signal allows the ECM to make a calculation of air density. The sensor is located in front of the measuring flap. For details about the sensor, refer to the Air Management section.

The ECM will adjust the ignition timing based on air temperature. If the intake air is hot the ECM retards the ignition timing to reduce the risk of detonation. If the intake air is cooler, the ignition timing will be advanced.

If this input is defective, a fault code will be set and the “Check Engine” Light will illuminate. The ignition timing will be set to a conservative basic setting.

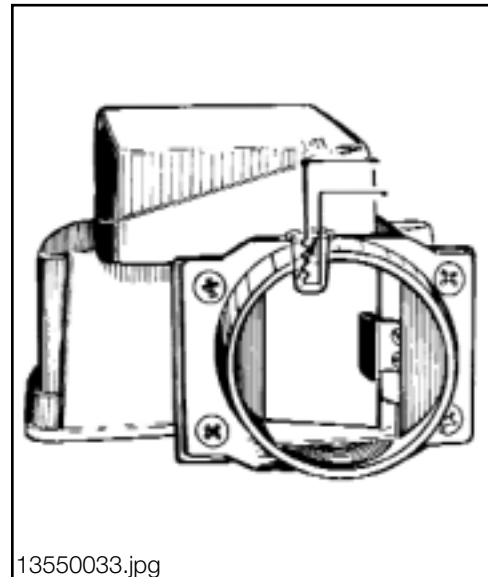

Principle of Operation

Ignition Management provides ignition to the combustion chambers with the required voltage at the correct time. Based on the combination of inputs, the ECM calculates and controls the **ignition timing** and **secondary output voltage** by regulating the activation and dwell of the **primary ignition circuit**. The ECM does not directly monitor secondary ignition output, although it does control and monitor the primary ignition circuit.

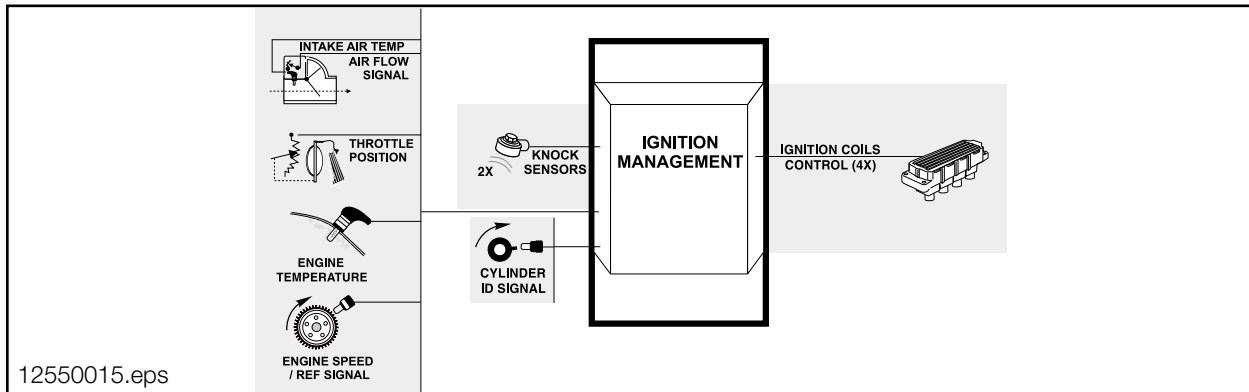

The ECM has a very “broad” range of ignition timing. This is possible by using a Direct Ignition System, or sometimes referred to as “Static Ignition System”. Reliability is also increased by having separate individual ignition circuits.

The Ignition Control is determined by the ECM (load dependant). The ECM will calculate the engine “load” based on a combination of the following inputs:

• Battery Voltage	• Throttle Position	• Air Flow Volume
• Air Temperature	• Engine Coolant	• Crankshaft Position/RPM
• Camshaft Position (Cylinder ID)	• Knock Sensors	

The dwell time will be regulated based on battery voltage. When cranking, the voltage is low and the ECM will increase the dwell to compensate for saturation “lag time”. When the engine is running and the battery voltage is higher, the ECM will decrease the dwell due to faster saturation time.

The Crankshaft Position/RPM signals the ECM to start ignition in firing order (1-3-4-2) as well as providing information about the engine operation. This input is used in combination with other inputs to determine engine load which advances/retards the ignition timing. Without this input, the ECM will not activate the ignition.

Cold start is determined by the ECM based on the engine coolant temperature and rpm during start up. A cold engine will crank over slower than a warm engine, the ignition timing will range between top dead center to slightly retarded providing optimum starting.

When starting a warm engine, the rpm is higher which results in slightly advanced timing. If the engine coolant and intake air temperature is hot, the ignition timing will not be advanced reducing starter motor “load”.

During cranking, the ECM recognizes the Camshaft Position (compression stroke) and activates a single ignition per cylinder.

If this signal is not recognized, the ECM will activate **“Double Ignition”**. The ignition coils will be activated on both the compression and exhaust strokes to maintain engine operation. The ignition timing will be progressively advanced assisting the engine in coming up to speed.

As the engine speed approaches idle rpm, the timing remains slightly advanced to boost torque. When the engine is at idle speed, minimum timing advance is required. This will allow faster engine and catalyst warm up.

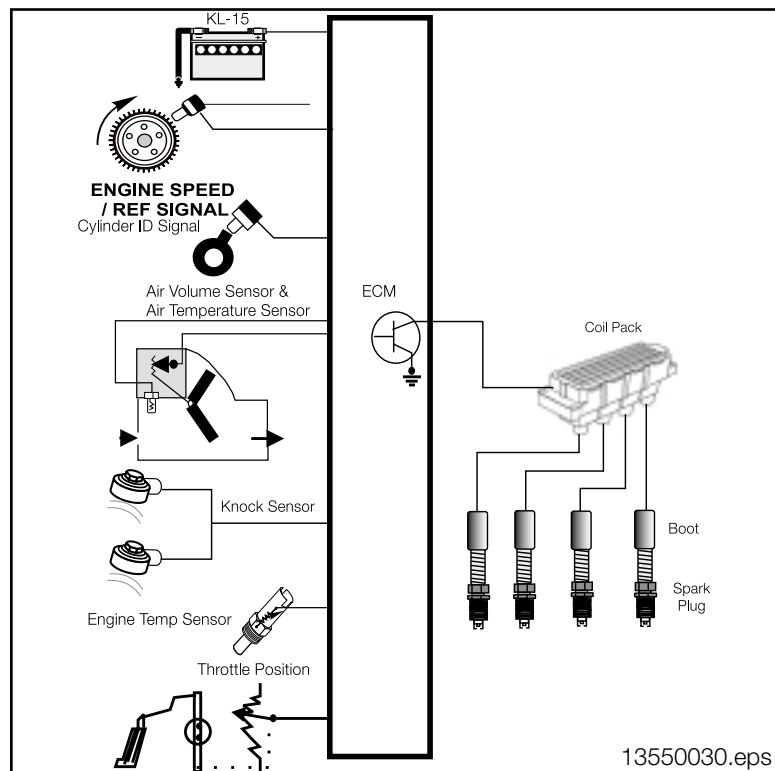

The timing will be advanced when the ECM observes low engine rpm and increasing throttle/air volume inputs (acceleration torque). As the throttle is opened, the ECM advances the timing based on engine acceleration and at what rate. The ECM will fully advance timing for the “full throttle” position indicating maximum acceleration (torque).

The Air Flow Volume signal provides the measured amount of intake air volume. This input is used by the ECM to determine the amount of timing advance to properly combust the air/fuel mixture.

The Air Temperature Signal assists the ECM in reducing the risk of detonation (ping). If the intake air is hot the ECM retards the ignition timing. If the intake air is cooler, the ignition timing will be advanced.

As the throttle is closed, the ECM decreases the ignition timing if the rpm is above idle speed (coasting). This feature lowers the engine torque for deceleration. When the engine rpm approaches idle speed, the timing is slightly advanced to prevent the engine from stalling. The amount of advance is dependent upon the engine temperature and the rate of deceleration.

Knock Control

The use of Knock Control allows the ECM to further advance the ignition timing under load for increased torque. This system uses two Knock Sensors located between cylinders 1 & 2 and between cylinders 3 & 4.

Knock Control is only in affect when the engine temperature is greater than 35 °C and there is a load on the engine. This will disregard false signals while idling or from a cold engine.

Based on the firing order, the ECM monitors the Knock Sensors after each ignition for a normal (low) signal.

If the signal value exceeds the threshold, the ECM identifies the “knock” and retards the ignition timing (3°) for that cylinder the next time it is fired.

This process is repeated in 3° increments until the knock ceases. The ignition timing will be advanced again in increments right up to the knock limit and maintain the timing at that point.

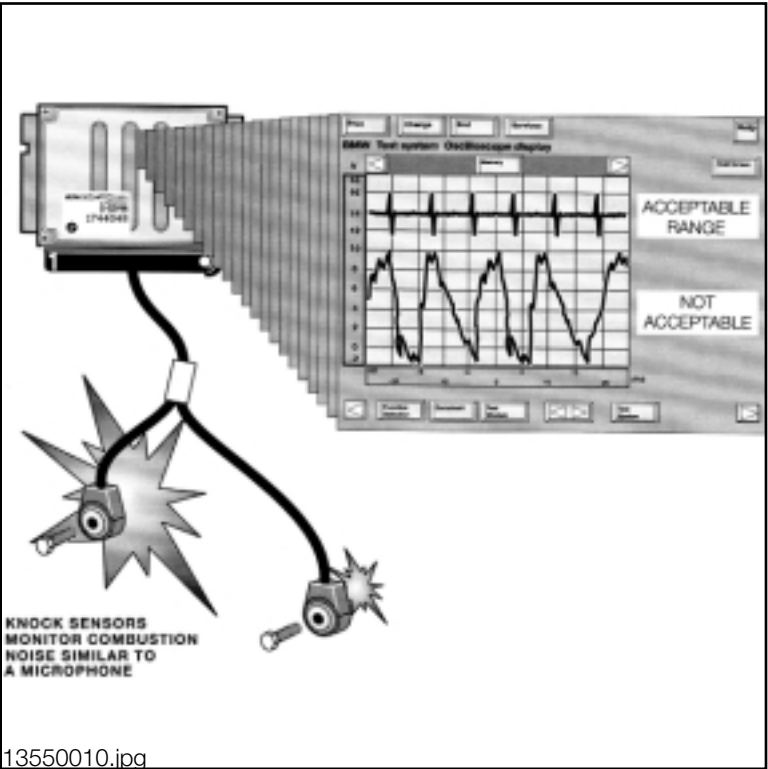

If a fault is detected with the Knock Sensor(s) or circuits, the ECM deactivates Knock Control. The “CHECK ENGINE” Light will be illuminated, the ignition timing will be set to a conservative basic setting (to reduce the risk of detonation) and a fault will be stored.

Workshop Hints

Before any service work is performed on any ignition system related component, always adhere to the following:

• Observe relevant safety legislation pertaining to your area
• Always wear adequate protection clothing including eye protection.
• Use caution when working around a HOT engine compartment.
• Always consult the REPAIR INSTRUCTIONS on the specific model you are working on before attempting a repair.
• Always SWITCH OFF THE IGNITION (KL15) before working on the ignition system.
• Use only BMW approved test leads.
• NEVER TOUCH COMPONENTS CONDUCTING CURRENT with the engine running.
• Do not connect suppression devices or a “test light” to terminal 1 of the ignition coils.
• Terminal 1 from the ignition coil to the ECM (High Voltage approximately 350 V)

HIGH VOLTAGE - DANGER!

Caution! Hazardous voltages occur at:

• Ignition Leads
• Spark Plug Connector
• Spark Plug
• Ignition Coil (High Voltage at terminal 4 is approximately 30 KV)
• Terminal 1 from the ignition coil to the ECM (High Voltage approximately 350V)

Ignition System Diagnosis

A fault survey should first be performed using the DIS/MoDIC to determine if there is a fault in the primary ignition or secondary ignition.

If there is a fault in the primary ignition, testing should include:

- **Power Supply at the Coil (KL15)**
- **Resistance of the harness and ignition coil primary winding (terminal 15 to 1 approximate 0.8 ohms) - using the 88 Pin Adapter with the ECM Disconnected**

- **ECM Primary Circuit Final Stage Transistor**
- **ECM Ignition Coil (one of four)**
- **Secondary Coil Ground**

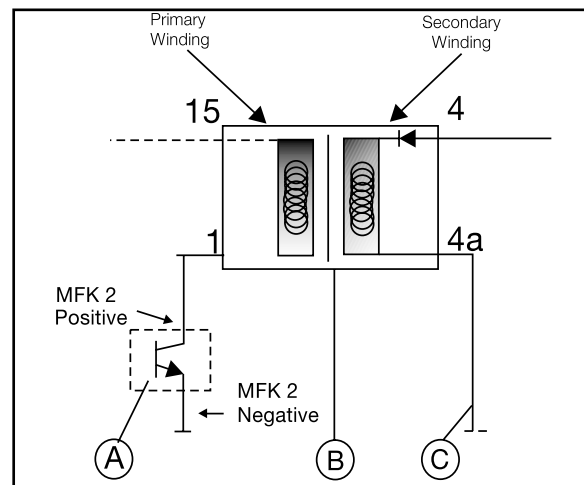

13550034.eps

- ECM Final Stage transistor activation. This test function is found under the Oscilloscope Preset list - "Ignition Signal Primary" (normal Terminal 1 Signal shown on the right).

Install the 88 Pin Adapter, Diagnostic cable, MFK 2 negative lead to ECM ground and MFK 2 positive lead to the ground activation circuit for Terminal 1 of the ignition coil. This test is performed with the engine running.

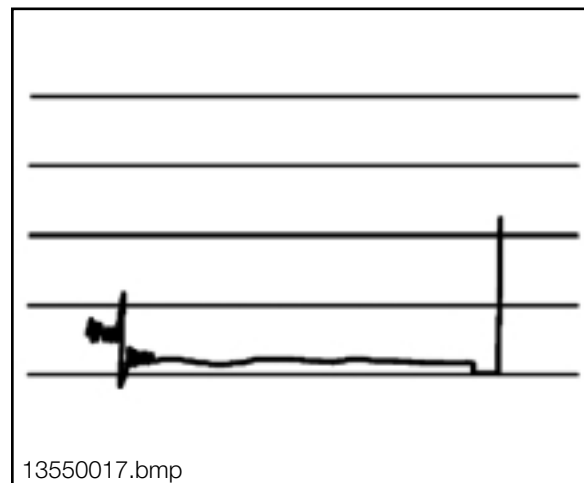

13550017.bmp

If there is a fault in the secondary ignition, testing should include:

- Primary Ignition**
- Evaluation of Secondary Oscilloscope Patterns**

The Following are Examples of Secondary Oscilloscope Patterns:

This is a normal pattern for one ignition circuit with the engine at idle speed.

- 1. Normal Combustion Period**
- 2. Normal Ignition Voltage Peak**

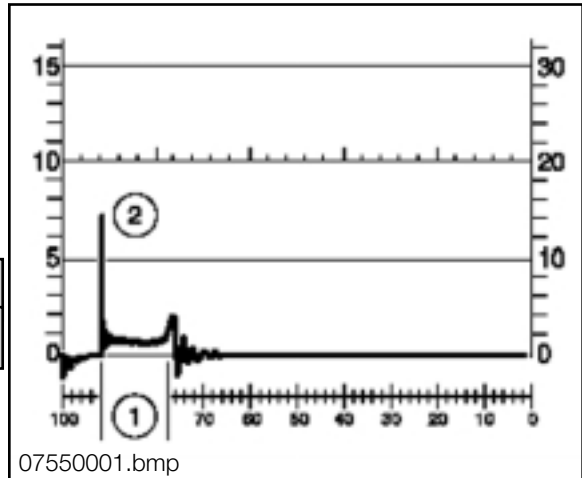

Long Spark Period (1) with Low Ignition Voltage Peak (2)

- Indicates Low Compression**

If Spark Period is Fluctuating:

- Contamination on Spark Plug or Defective Spark Plug**

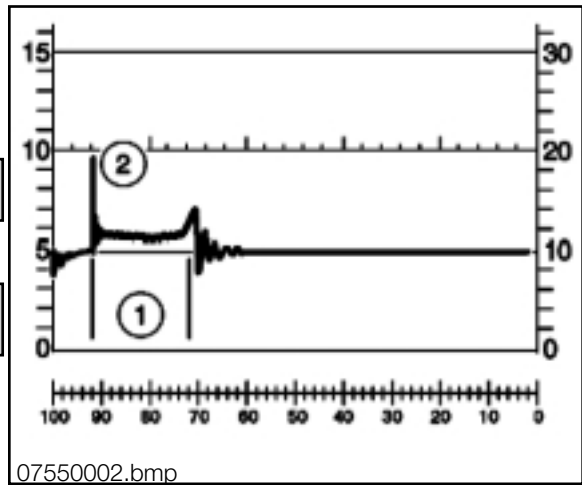

Short Spark Period (1) with High Ignition Voltage Peak (2).

- Defective Ignition Cable, Connector, or Resistive Adapter Boot**

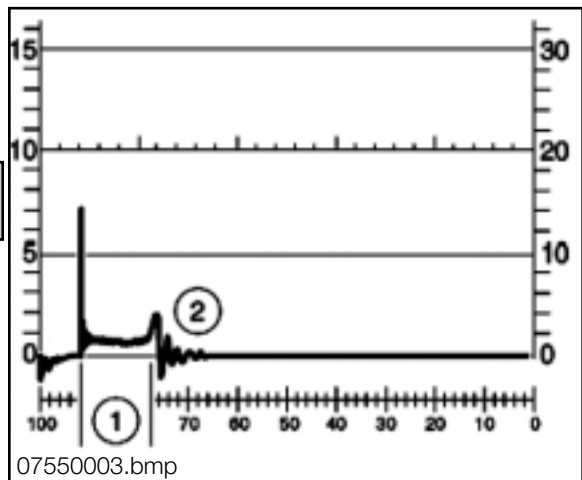

Evaluation of Ignition Voltage Peaks at Idle Speed (All Cylinders Displayed).

- Normal Attenuation (Voltage Reduction) Process
- Shorten Attenuation Process-Defective Ignition Coil
- Absence of Attenuation - Defective Ignition Coil

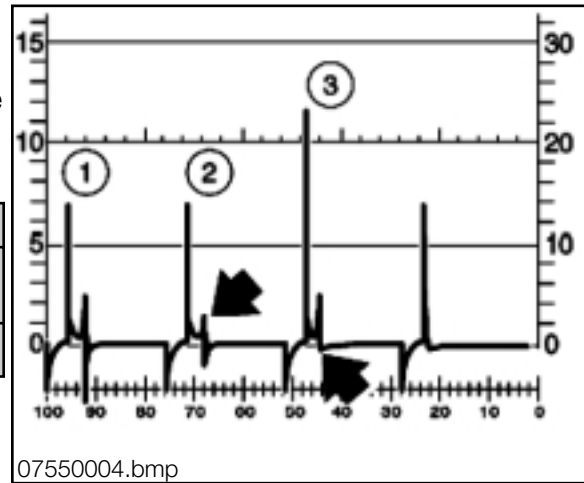

No Sparking Voltage Line (Single Cylinder Displayed)

- Defective Ignition Coil

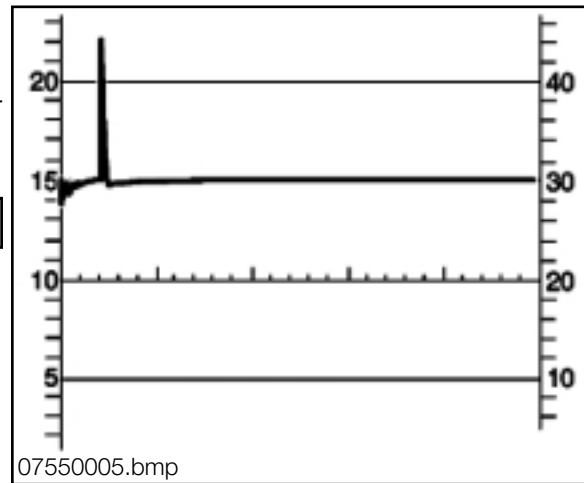

Evaluation of Ignition Voltage Peaks under Sudden Loads (All Cylinders Displayed).

- Decaying Process is not much Higher than Ignition Voltage Peak - System is Ok.
- Decaying Process is considerably Higher than Ignition Voltage Peak:
- Lean Mixture
- Defective Fuel Injector
- Low Compression

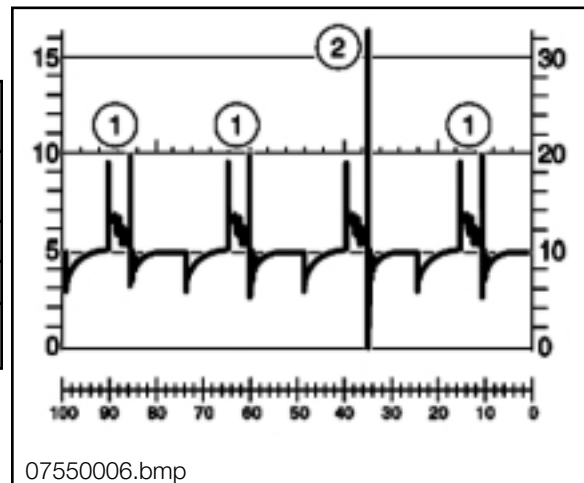

The Repair Instructions should be consulted for additional Oscilloscope Patterns under various engine speeds.

In Summary,

If the Secondary Ignition **Voltage is Too High (Excessive Resistance for Ignition):**

• Spark Plug Gap is too Large (Worn or Burned)
• Incorrect Heat Range Spark Plug
• Compression is too High (Carbon, etc.)
• Lean Mixture (Vacuum Leak, etc.)
• Interruption in the Secondary Ignition Cable, Connector, or Resistive Adapter Boot

If the Secondary Ignition **Voltage is Too Low (Low Resistance for Ignition):**

• Spark Plug Gap is Too Small (Mishandled on Installation)
• Incorrect Heat Range Spark Plug
• Compression is Too Low
• Voltage Leak in the Secondary Ignition Cable, Connector, or Resistive Boot to Ground

Spark Plugs

The Spark Plugs should be inspected for the proper type, gap and replaced at the specified intervals.

Refer to the Service Information Bulletin S.I. #12 01 99 for the proper type and a visual of the spark plug (showing effects of combustion, fouling, etc.)

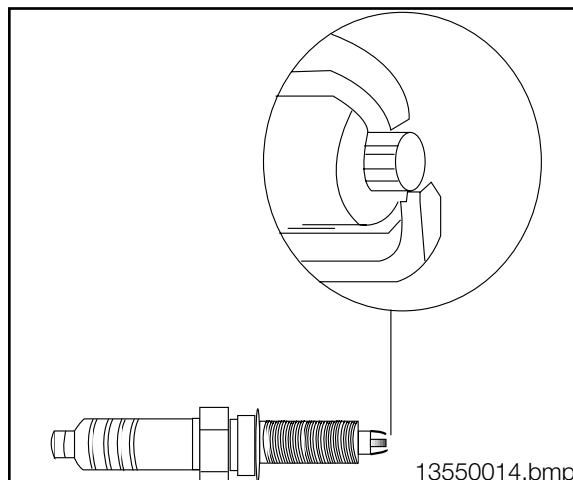

Ignition Leads

The secondary ignition cable (high tension lead) assembly includes the Connector Socket, Ignition Cable and Resistive Adapter Boot. These components should be visually inspected and checked for resistance.

For example, the Resistive Adapter Boot has a different ohmic value depending on the manufacturer:

- **Bosch - 1k ohm +/- 20%**
- **Bremi - 1.8k ohm +/- 20%**

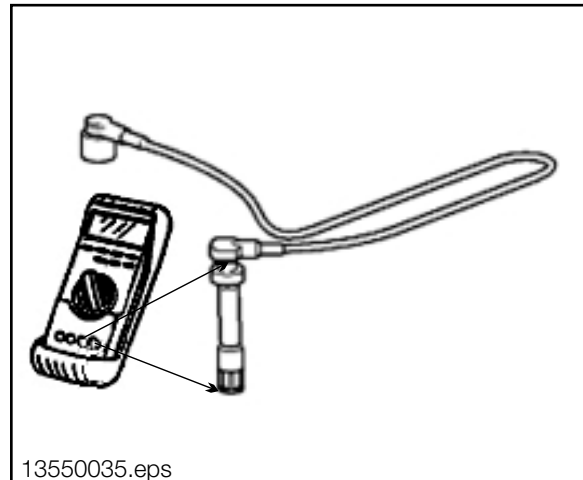

Knock Sensors

The Knock Sensors should be tested using the DIS/MoDIC for:

- **Fault Codes**
- **Status Display - Knock Control (active / not active)**
- **Oscilloscope Display (Low DC Voltage - mV setting)**

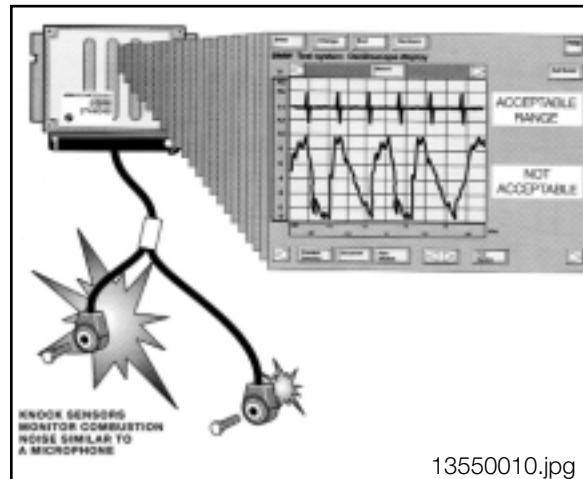

When installing Knock Sensors:

DO NOT MIX THE CONNECTORS: Engine Damage will result! - the connector is critical to sensor location (1) cylinder 1 & 2 and (2) cylinder 3 & 4.

Do Not Over Tighten attaching bolt! - Piezo ceramic will be cracked. Torque to 20 nm.

Do Not Under Tighten attaching bolt, a loose sensor can vibrate producing a similar signal to a knock.

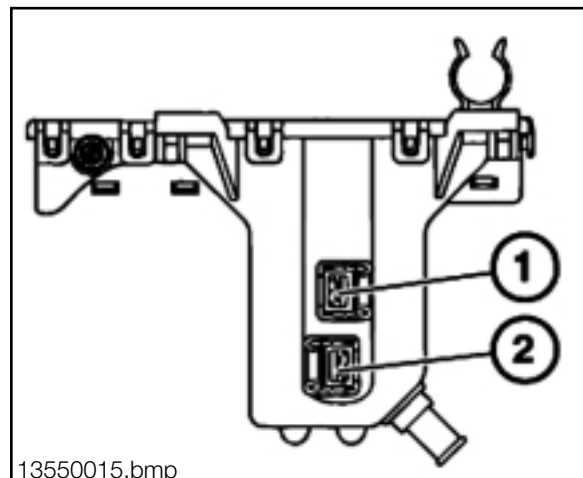

Tools and Equipment

The DIS/Modic as well as a reputable hand held multimeter can be used when testing inputs/components.

It is best to make the checks at the ECM connection, this method includes testing the wiring harness.

The correct Universal Adapter for the M1.7.2 application should be used (#88 88 6 614 410). This will ensure the pin connectors and the harness will not be damaged.

The interior of this Universal Adapter is shielded, therefore it is vital that the ground cable is connected to the vehicle chassis whenever the adapter is used.

The adapter uses a Printed Circuit board inside keeping the capacitive and inductive load to a minimum.

When installing the Universal Adapter to the ECM (located below the windshield on the passenger side of the engine compartment), make sure the ignition is switched off.

When Testing the Secondary Ignition System, use the High Tension clip of the DIS. Refer to the HELP button for additional (on screen) connections.

Caution!

Observe Safety Precautions, High Voltage is Present with the Engine Running.

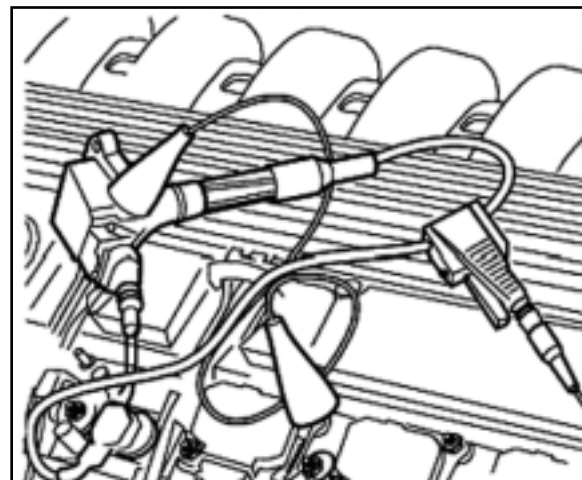
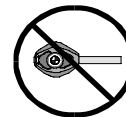
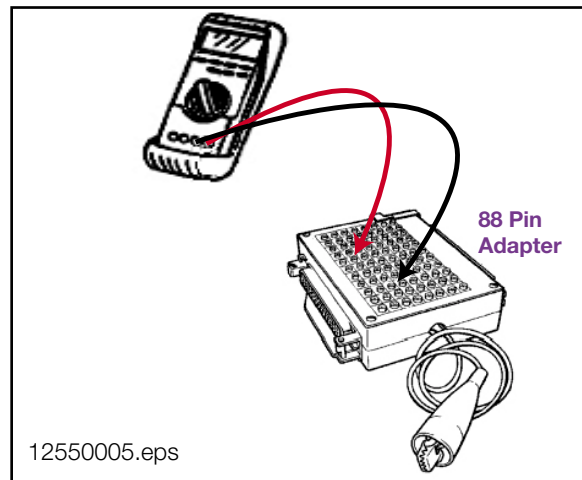
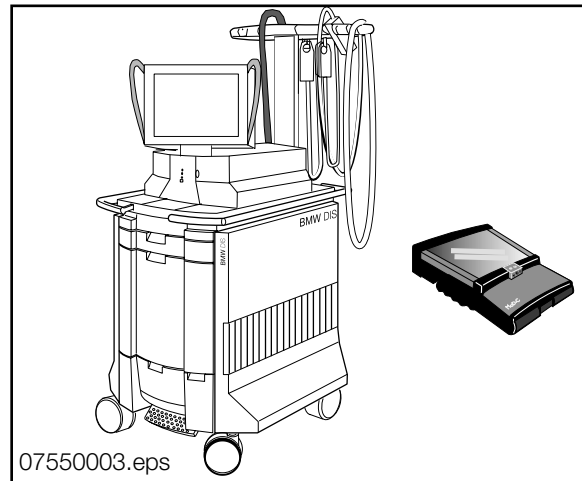

13550016.bmp

The secondary ignition cables, connectors and sockets can be replaced separately.

New connectors can be “crimped” on using Special Tool #12 1 081. This tool provides a two stage crimp, crimping the core conductor (1) and the insulator (2).

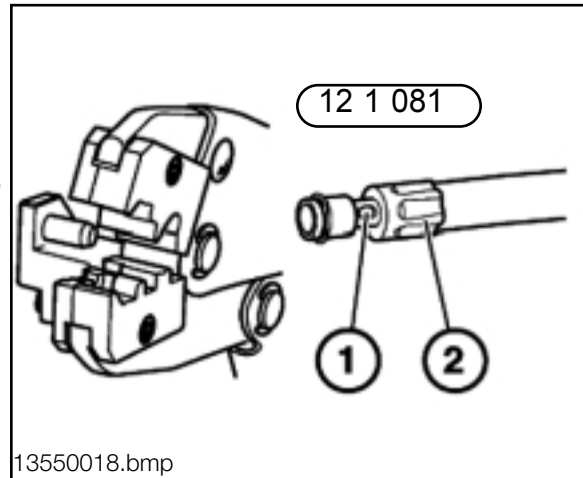

The connector with ignition cable should be installed into the Resistive Adapter Boot with Special Tools #12 1 087 and #12 1 086 to ensure the connector properly “seats”.

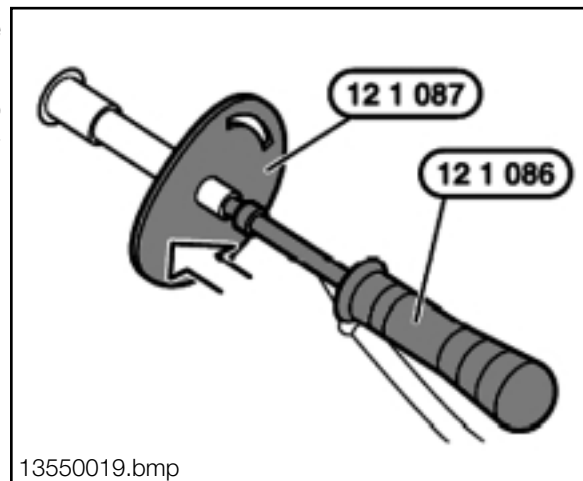

The Spark Plugs should be properly installed and torqued using the following Special Tools:

- 12 1 200 Torque Adapter (prevents over tightening)
- 12 1 171 Spark Plug Socket

NOTE: NEVER USE AIR TOOLS FOR REMOVAL OR INSTALLATION!

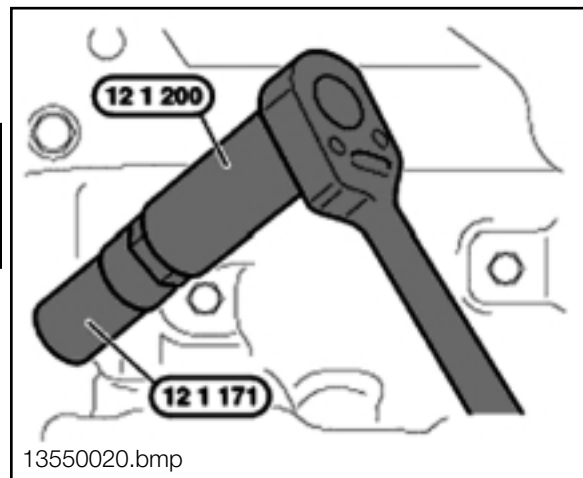

Emissions Management - HC II Compliant (as of 96 MY)

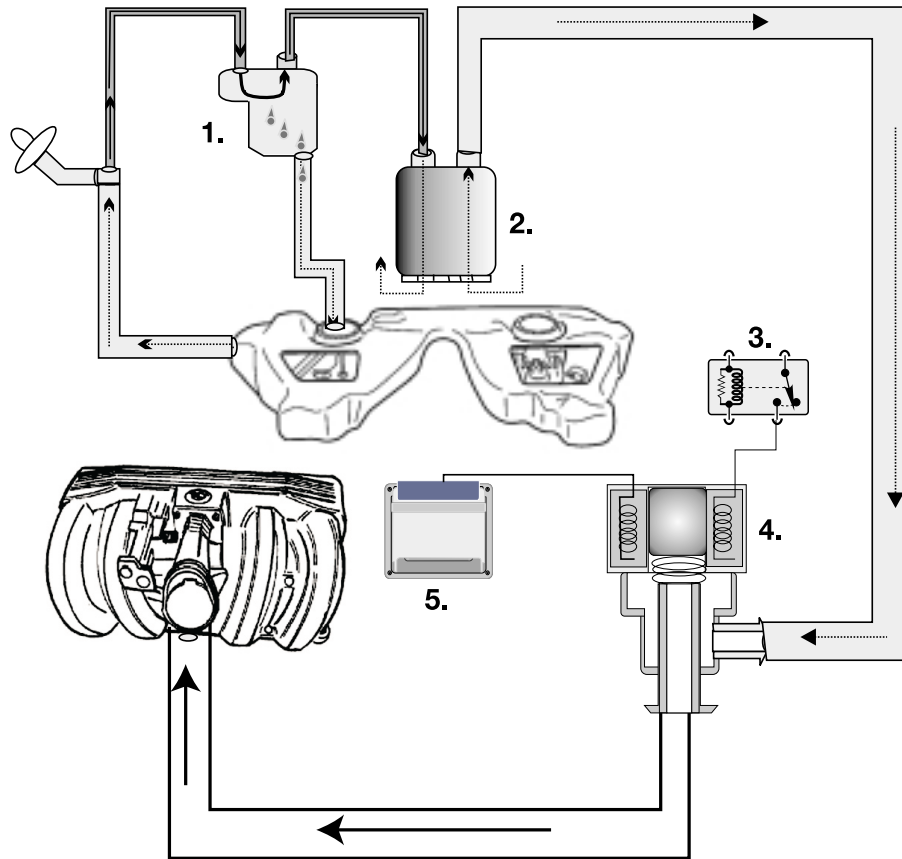

18550000eps

1. Liquid/Vapor Separator	3. ECM Relay	5. ECM
2. Active Carbon Canister	4. Evaporative Emission Valve	

Evaporative Emissions: The control of the evaporative fuel vapors (Hydrocarbons) from the fuel tank is important for the overall reduction in vehicle emissions. The evaporative system has been combined with the ventilation of the fuel tank, which allows the tank to breathe (equalization). The overall operation provides:

- An inlet vent, to an otherwise “sealed” fuel tank, for the entry of air to replace the fuel consumed during engine operation.
- An outlet vent with a storage canister to “trap and hold” fuel vapors that are produced by the expansion/evaporation of fuel in the tank, when the vehicle is stationary.

The canister is then “purged” using the engine vacuum to draw the fuel vapors into the combustion chamber. This “cleans” the canister allowing for additional storage. Like any other form of combustible fuel, the introduction of these vapors on a running engine must be controlled. The ECM controls the Evaporative Emission Valve which regulates purging of evaporative vapors.

Liquid/Vapor Separator: Fuel vapors are routed from the fuel tank filler neck through a hose to the Liquid/Vapor Separator (located in the right rear wheel well behind the trim). The vapors cool when exiting the fuel tank, the condensates separate and drain back to the fuel tank through a return hose (1). The remaining vapors exit the Liquid/Vapor Separator to the Active Carbon Canister.

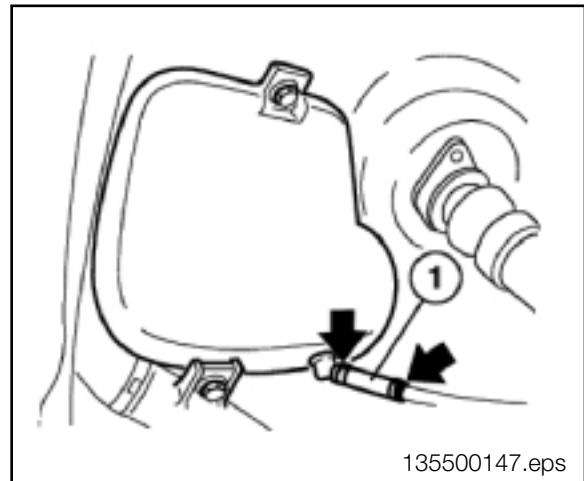

Active Carbon Cannister: As the hydrocarbon vapors enter the canister, they will be absorbed by the active carbon. The remaining air will be vented to the atmosphere through the end of the canister allowing the fuel tank to “breathe”.

When the engine is running, the canister is then "purged" using intake manifold vacuum to draw air through the canister which extracts the hydrocarbon vapors into the combustion chamber. The Active Carbon Canister is located in the engine compartment on the left strut tower (spare tire well on late 95 MY).

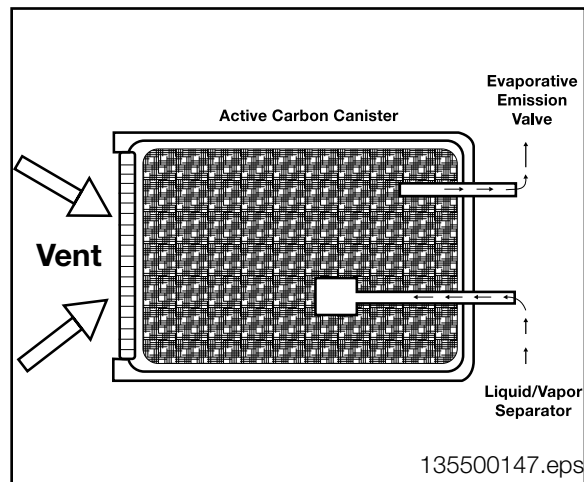

Evaporative Emission Valve: This ECM controlled solenoid valve regulates the purge flow from the Active Carbon Canister into the intake manifold (located next to the Air Volume Mass Meter).

The ECM Relay provides operating voltage, and the ECM controls the valve by regulating the ground circuit. The valve is powered closed and opened by an internal spring.

If the Evaporative Emission Valve circuit is defective, a fault code will be set and the “CHECK ENGINE” Light will illuminate. If the valve is “mechanically” defective, a driveability complaint could be encountered and a mixture related fault code will be set.

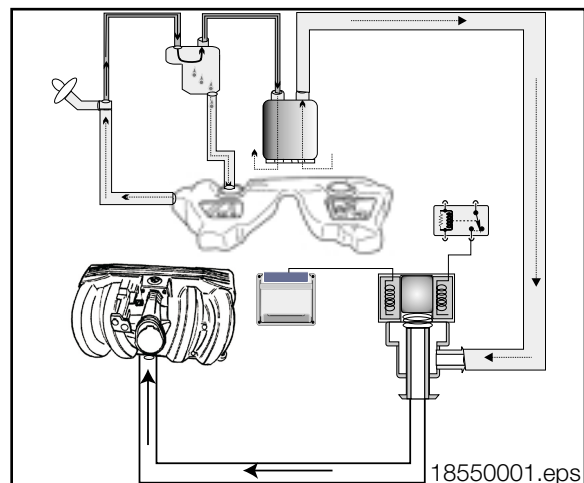

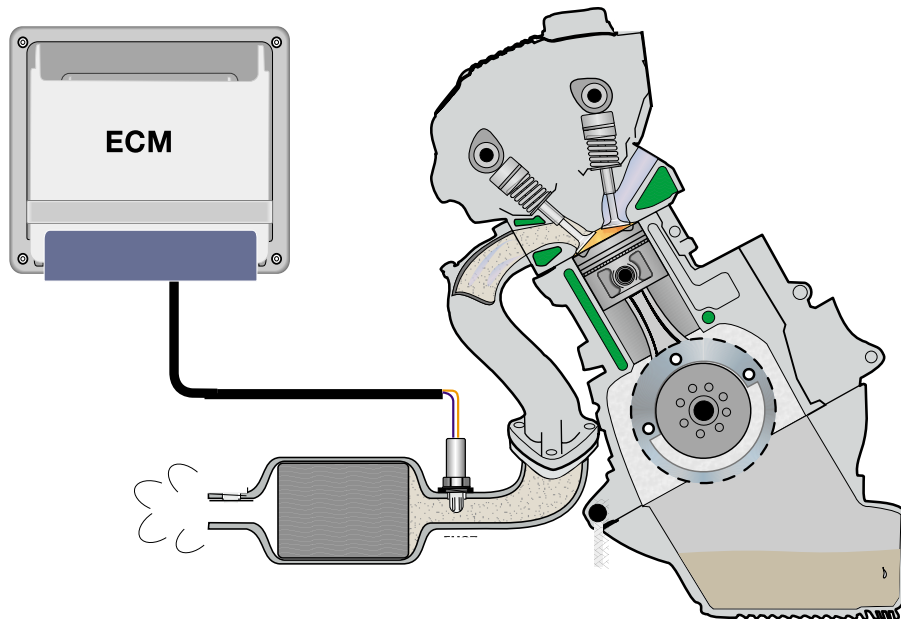

12550016.eps

Exhaust Emissions: The combustion process of a gasoline powered engine produces Carbon Monoxide (CO), Hydrocarbons (HC) and Oxides of Nitrogen (NOx).

- **Carbon Monoxide is a product of incomplete combustion under conditions of air deficiency. CO emissions are strongly dependent on the air/fuel ratio.**
- **Hydrocarbon are also a product of incomplete combustion which results in unburned fuel. HC emissions are dependent on air/fuel ratio and the ignition of the mixture.**
- **Oxides of Nitrogen are a product of peak combustion temperature (and temperature duration). NOx emissions are dependent on internal cylinder temperature affected by the air/fuel ratio and ignition of the mixture.**

Control of exhaust emissions is accomplished by the engine and engine management design as well as after-treatment.

- **The ECM manages exhaust emissions by controlling the air/fuel ratio and ignition.**
- **The Catalytic Converter further reduces exhaust emissions leaving the engine.**

Bosch Oxygen Sensor: The oxygen sensor measures the residual oxygen content of the exhaust gas. The sensor produces a low voltage (0-1000 mV) proportional to the oxygen content that allows the ECM to monitor the air/fuel ratio. If necessary, the ECM will “correct” the air/fuel ratio by regulating the ms injection time. The sensor is mounted in the hot exhaust stream directly in front of the catalytic converter.

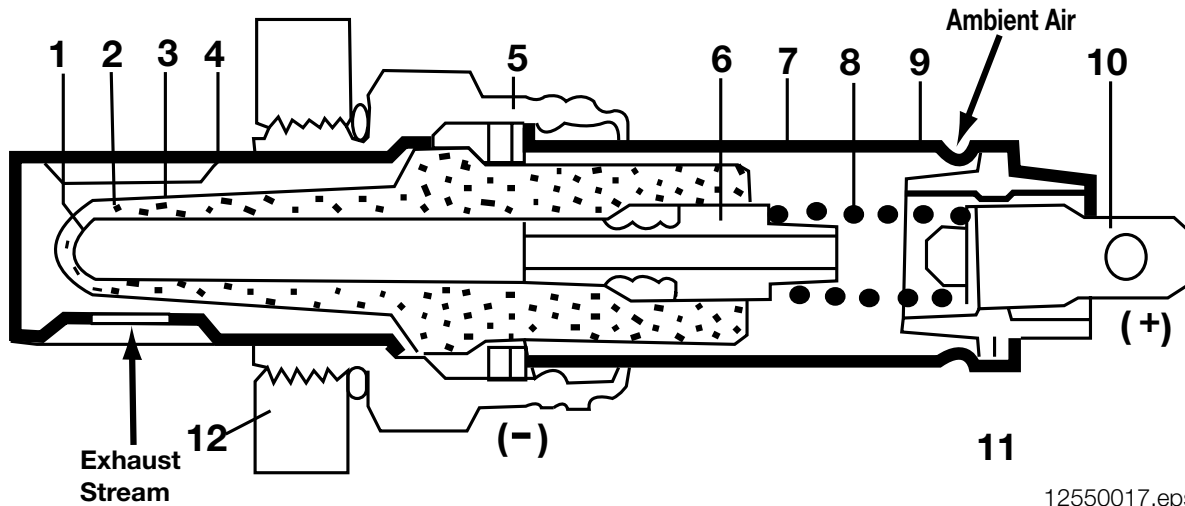

12550017.eps

1. Electrode (+)	7. External Body (Ventilated)
2. Electrode (-)	8. Contact Spring
3. Porous Ceramic Coating (Encasing Electrolyte)	9. Vent Opening
4. Protective Metal Cage (Ventilated)	10. Output Lead
5. Casing	11. Insulator
6. Contact Sleeve	12. Exhaust

The “tip” of the sensor contains a microporous platinum coating (electrodes) which conduct current. The platinum electrodes are separated by solid electrolyte which conducts oxygen ions.

The platinum conductors are covered with a highly porous ceramic coating and the entire tip is encased in a ventilated metal “cage”. This assembly is submersed in the exhaust stream. The sensor body (external) has a small vent opening in the housing that allows ambient air to enter the inside of the tip.

The ambient air contains a constant level of oxygen content (21%) and the exhaust stream has a much lower oxygen content. The oxygen ions (which contain small electrical charges) are “purged” through the solid electrolyte by the hot exhaust gas flow. The electrical charges (low voltage) are conducted by the platinum electrodes to the sensor signal wire that is monitored by the ECM.

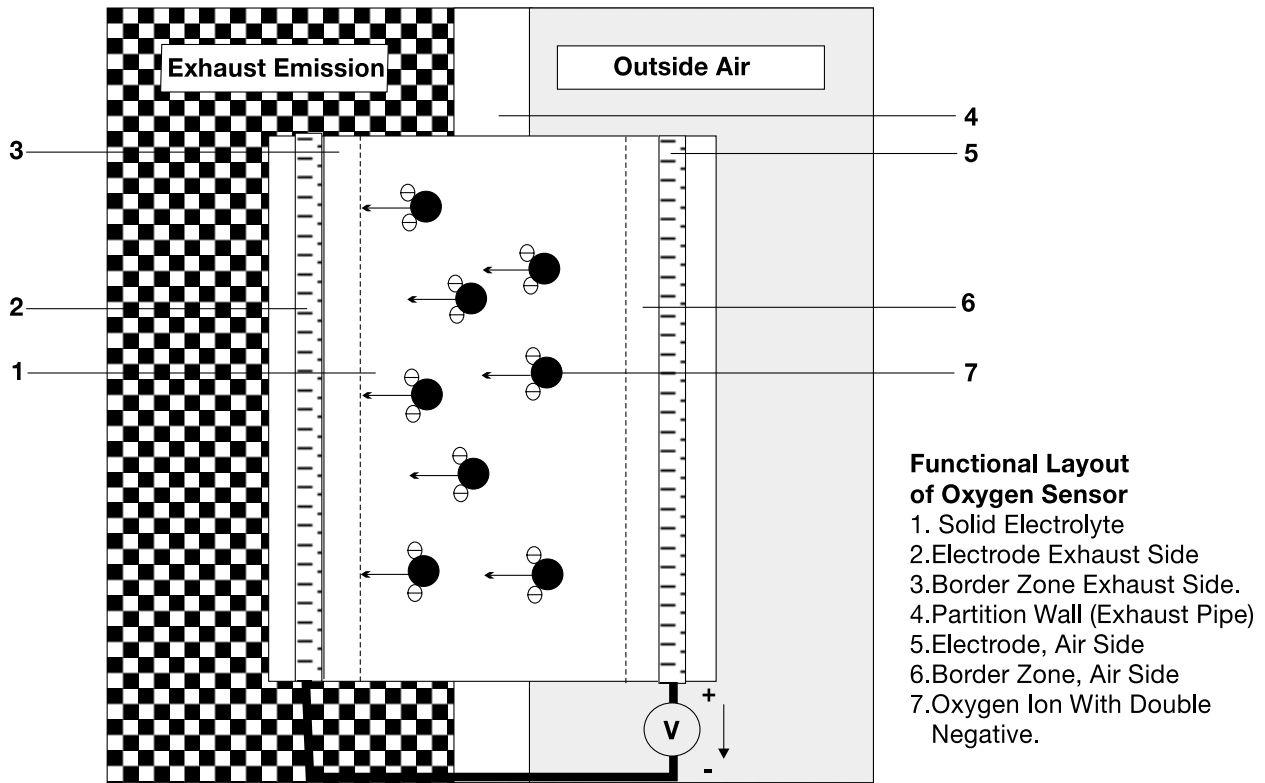

18550002.eps

If the exhaust has a lower oxygen content (rich mixture), there will be a large ion “migration” through the sensor generating a higher voltage (950 mV). If the exhaust has a higher oxygen content (lean mixture), there will be a small ion “migration” through the sensor generating a lower voltage (080 mV).

This voltage signal is constantly changing due to combustion variations and normal exhaust pulsations.

The ECM monitors the length of time the sensor is operating in the lean, rich and rest conditions. The evaluation period of the sensor is over a predefined number of oscillation cycles.

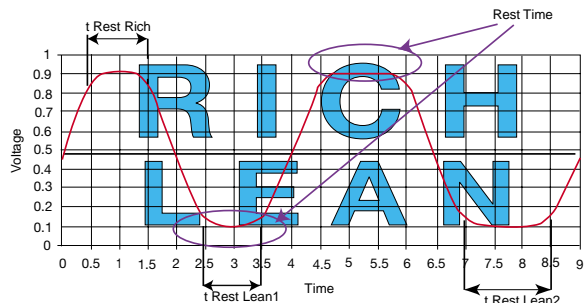

13550011.eps

This conductivity is efficient when the oxygen sensor is hot (250° - 300° C). For this reason, the sensor contains a heating element. This “heated” sensor reduces warm up time, and retains the heat during low engine speed when the exhaust temperature is cooler.

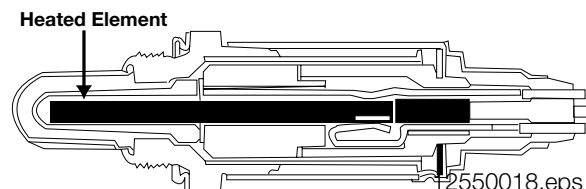

12550018.eps

Catalytic Converter: The three-way catalyst after-treats exhaust emissions leaving the engine. A properly operating catalyst consumes most of the oxygen that is present in the exhaust gas which is a result of burning the remaining pollutants. The oxygen sensor monitors the air/fuel mixture which allows the ECM to maintain the correct mixture for catalyst efficiency. The gases that flow into the catalyst are converted from CO, HC and NO_x to CO₂, H₂O and N₂ respectively.

The catalytic converter (monolith) is made of thousands of small ceramic blocks that the exhaust must flow through. The entire ceramic structure is supported in the shell by a flexible mat and wire mesh layer.

The ceramic is coated with the precious metals Platinum which speeds up oxidation of HC and CO and Rhodium which speeds up the reduction of NO_x.

The exhaust flow heats the catalyst and with the remaining oxygen, the exhaust pollutants are further reduced by burning. The temperature operating range for the highest efficiency is 400° - 800° C which is also influenced by the air/fuel mixture.

The M1.7.2 system uses the redesign catalytic converter which distributes the exhaust gas uniformly as it enters the converter through a lateral discharge inlet.

This design allows the exhaust gas to strike the entire surface of the monolith to ensure that emissions from the exhaust system are reduced to a consistently low level.

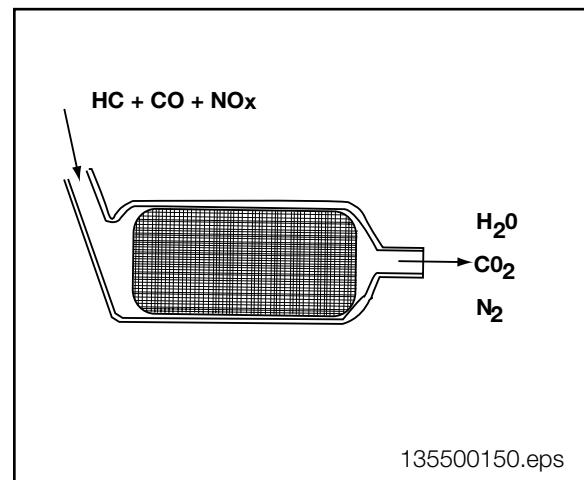
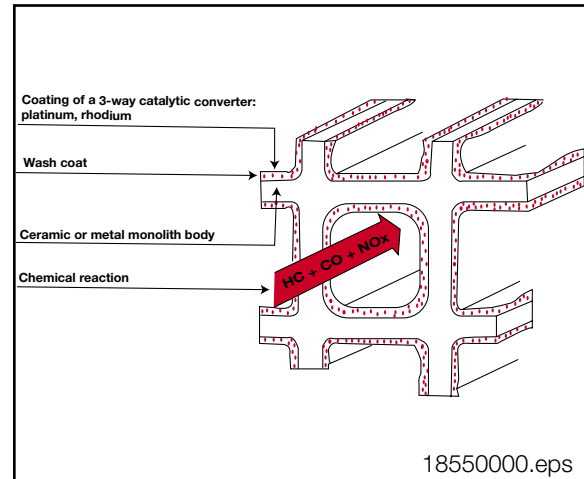

Principle of Operation

Emissions Management controls evaporative and exhaust emissions. The ECM controls the **purging** of evaporative fuel. The ECM monitors and controls the exhaust emissions by regulating the **combustable mixture**. The catalytic converter after-treats by further breaking down remaining combustable exhaust gasses.

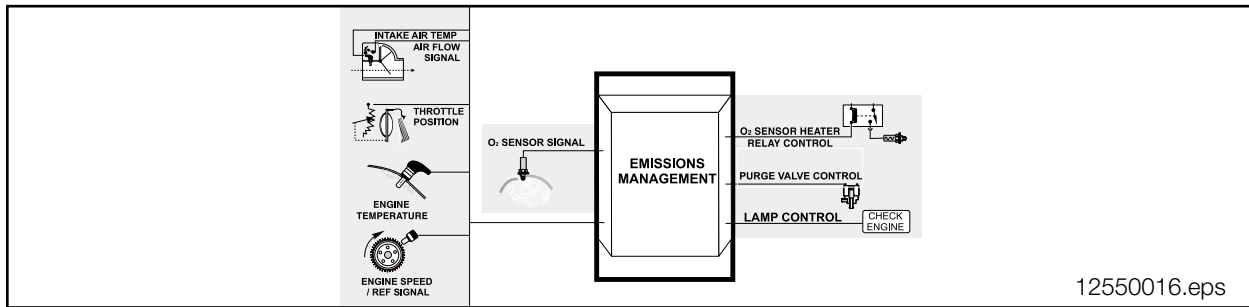

Evaporative Emission Purging is regulated by the ECM controlling the Evaporative Emission Valve. The Evaporative Emission Valve is a solenoid that regulates purge flow from the Active Carbon Cannister into the intake manifold. The ECM Relay provides operating voltage and the ECM controls the valve by regulating the ground circuit. The valve is powered closed and opened by an internal spring. The “purging” process takes place when:

- **Oxygen Sensor Control is active**
- **Engine Coolant Temperature is >60°C**
- **Engine Load is present**

The Evaporative Emission Valve is opened in stages to moderate the purging.

- **Stage 1 opens the valve for 10 ms (milli-seconds) and then closes for 150 ms.**
- **The Stages continue with increasing opening times (up to 16 stages) until the valve is completely open.**
- **The Valve now starts to close in 16 stages in reverse order.**
- **This staged process takes 6 minutes to complete. The function is inactive for 1 minute then starts the process all over again.**
- **During the purging process the valve is completely opened during full throttle operation and is completely closed during deceleration fuel cutoff.**

Evaporative Purge System Flow Check (1996 MY - HC II Emission Compliance) is performed by the ECM when the oxygen sensor control and purging is active. When the Evaporative Emission Valve is open the ECM detects a lean/rich shift as monitored by the oxygen sensors indicating the valve is functioning properly. If the ECM does not detect a lean/rich shift, a second step is performed when the vehicle is stationary and the engine is at idle speed. The ECM opens and close the valve (abruptly) several times and monitors the engine rpm for changes. If there are no changes, a fault code will be set.

Fuel System Monitoring is performed by the ECM which verifies the calculated injection time (t_i) in relation to engine speed, load and the oxygen sensor signal as a result of the residual oxygen in the exhaust stream.

The ECM uses the oxygen sensor signal as a correction factor for adjusting and optimizing the mixture pilot control under all engine operating conditions.

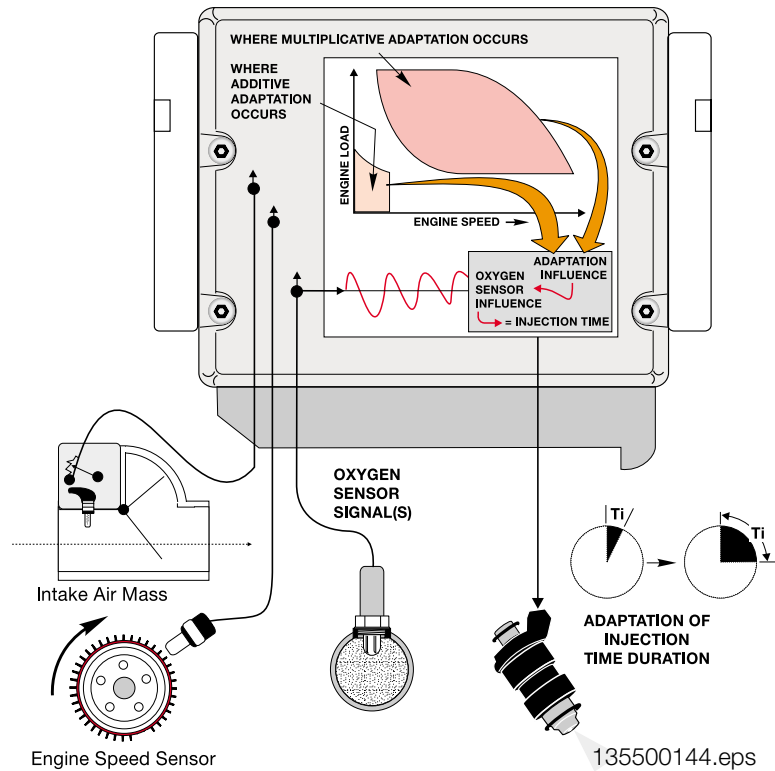

Adaptation Values are stored by the ECM in order to maintain an "ideal" air/fuel ratio. The ECM is capable of adapting to various environmental conditions encountered while the vehicle is in operation (changes in altitude, humidity, ambient temperature, fuel quality, etc.).

The adaptation can only make slight corrections and can not compensate for large changes which may be encountered as a result of incorrect airflow or incorrect fuel supply to the engine.

Within the areas of adjustable adaption, the ECM modifies the injection rate under two areas of engine operation:

- **During idle and low load mid range engine speeds (Additive Adaptation).**
- **During operation under a normal to higher load when at higher engine speeds (Multiplicative Adaptation).**

These values indicate how the ECM is compensating for a less than ideal initial air/fuel ratio.

NOTE: If the adaptation value is greater than "0.0 ms" the ECM is trying to richen the mixture. If the adaptation value is less then "0.0 ms" the ECM is trying to lean-out the mixture.

Oxygen Sensor Heating is controlled by the ECM to reduce warm up time and retain heat during low engine rpm when the exhaust temperature is cooler.

Voltage is supplied from the Oxygen Sensor Heater Relay and the ground circuit for the relay is provided by the ECM when engine rpm is present.

During full throttle operation electrical heating is not required and is deactivated by the ECM.

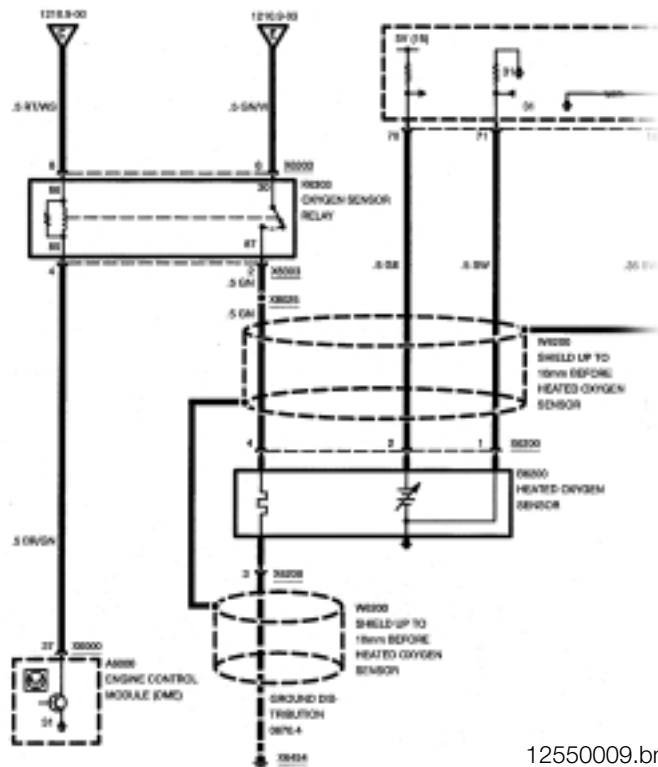

12550009.bmp

Oxygen Sensor Heater Relay Monitoring is checked separately for electrical integrity and operation. The Heater Relay function is monitored continuously while the vehicle is in closed loop operation, during activation by the ECM.

An improperly/non operating Heater Relay will not allow the sensor signal to reach its pre-defined maximum and minimum thresholds which can:

- **Result in delayed closed loop operation causing an impact on emission levels.**
- **Result in increased emission levels while in closed loop operation.**

As part of the monitoring function for Heater Relay current and voltage, the circuit is also checked for an open, short to ground and short to B+ depending on the values of the current or voltage being monitored. If the power of the Heater Relay is not within a specified range, a fault will be set and the "CHECK ENGINE" light will be illuminated.

The **“CHECK ENGINE” Light** required for OBD is located in the instrument cluster and is activated by the ECM under the following conditions:

- Ignition “on” (KL15) and engine not running-bulb check function.
- A component malfunction that affects the vehicle emissions.
- An Implausible input signal is generated
- Manufacturer-defined specifications are exceeded.
- ECM fails to enter oxygen sensor closed-loop control within a specified time interval.

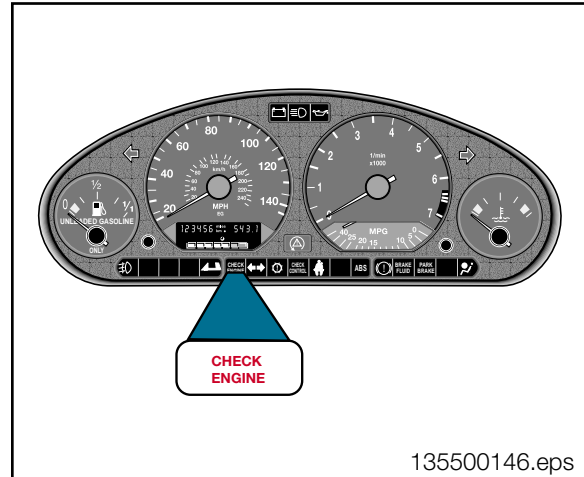

The ECM illuminates the “CHECK ENGINE” Light by activating a final stage transistor to supply a ground circuit (arrow). The light has voltage supplied whenever KL15 is switched “on”.

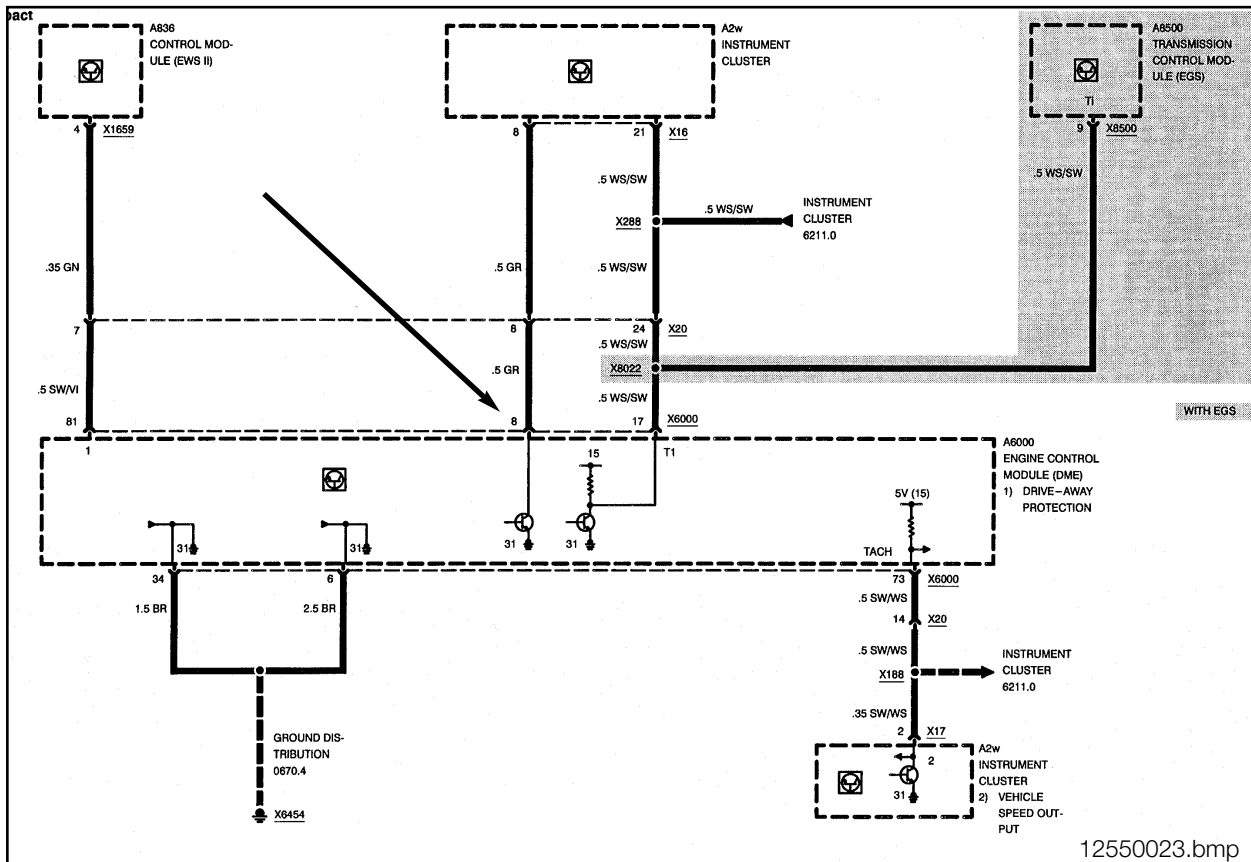

Workshop Hints

Before any service work is performed on any fuel system related component, always adhere to the following:

- | |
|---|
| • Observe relevant safety legislation pertaining to your area. |
| • Ensure adequate ventilation. |
| • Use exhaust extraction system where applicable (alleviate fumes). |
| • DO NOT SMOKE while performing fuel system repairs. |
| • Always wear adequate protection clothing including eye protection. |
| • Use caution when working around a HOT engine compartment. |
| • BMW does not recommend any UNAUTHORIZED MODIFICATIONS to the fuel system. The fuel systems are designed to comply with strict Federal Safety and Emissions Regulations. In the concern of product liability, it is unauthorized to sell or perform modifications to customer vehicles, particularly in safety related areas. |
| • Always consult the REPAIR INSTRUCTIONS on the specific model you are working on before attempting a repair. |



The **“CHECK ENGINE” Light** also has flash code readouts that allows Technicians without BMW Special Tools or Equipment to Diagnose an emission system failure.

For more information and ordering procedure for the On-Board Emission System Diagnostic Guide refer to Service Information Bulletin SI #13 08 88 (1718).

<p>CHECK ENGINE</p>

Oxygen Sensor Wiring Harness Voluntary Recall Campaign No. 98E-A02 pertains to oxygen sensor harness breakage due to the retainer clips (1 and 2). For more information and details, refer to Service Information Bulletin SI # 11 03 98.

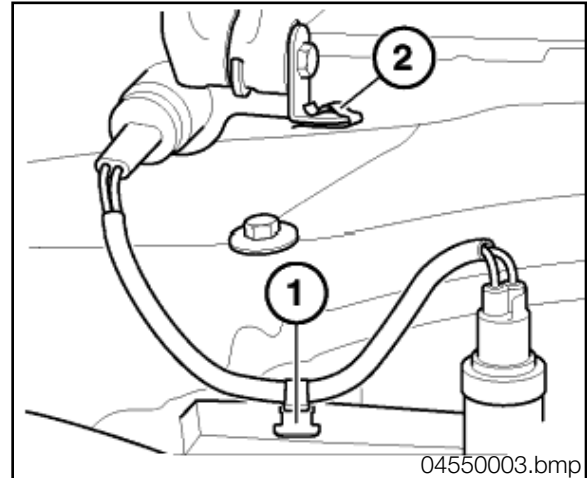
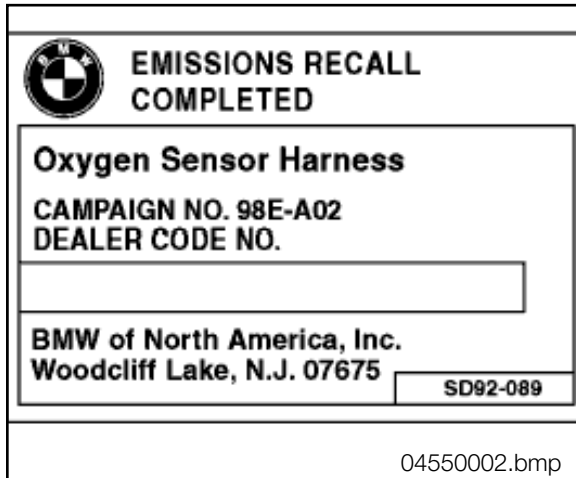

Testing the Oxygen Sensor should be performed using the DIS Oscilloscope from the “Preset” List. The scope pattern should appear as below for a normal operating sensor.

If the signal remains high (rich condition) the following should be checked:

- Fuel Injectors
- Fuel Pressure
- Ignition System
- Input Sensors that influence air/fuel mixture
- Engine Mechanical

If the signal remains low (lean condition) the following should be checked:

- Air/Vacuum Leaks
- Fuel Pressure
- Input Sensor that influence air/fuel mixture
- Engine Mechanical

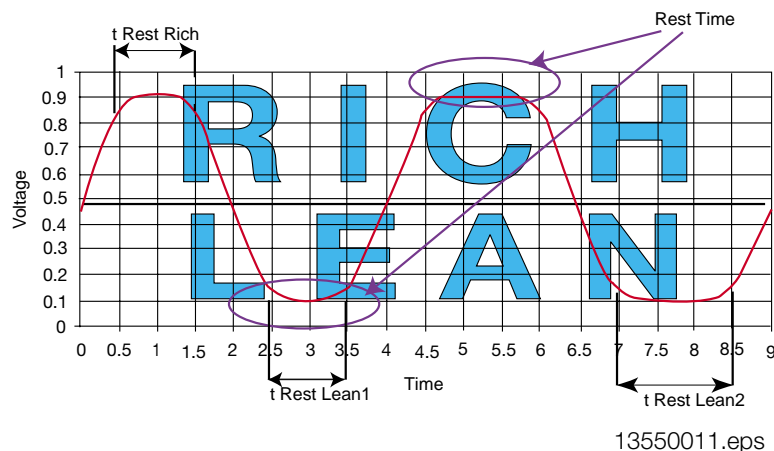

NOTE: A MIXTURE RELATED FAULT CODE SHOULD BE INVESTIGATED FIRST AND DOES NOT ALWAYS INDICATE A DEFECTIVE OXYGEN SENSOR!

Tools and Equipment

The DIS/Modic as well as a reputable hand held multimeter can be used when testing inputs/components.

It is best to make the checks at the ECM connection, this method includes testing the wiring harness.

The correct Universal Adapter for the M1.7.2 application should be used (#88 88 6 614 410). This will ensure the pin connectors and the harness will not be damaged.

The interior of this Universal Adapter is shielded, therefore it is vital that the ground cable is connected to the vehicle chassis whenever the adapter is used.

The adapter uses a Printed Circuit board inside keeping the capacitive and inductive load to a minimum.

When installing the Universal Adapter to the ECM (located below the windshield on the passenger side of the engine compartment), make sure the ignition is switched off.

Troubleshooting the closed-loop oxygen sensor control should be performed using Special Tool # 90 88 6 117 450 (operational instruction book included).

Refer to Repair Information 13 00 060 for detailed information on checking exhaust contents.

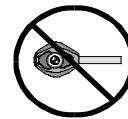
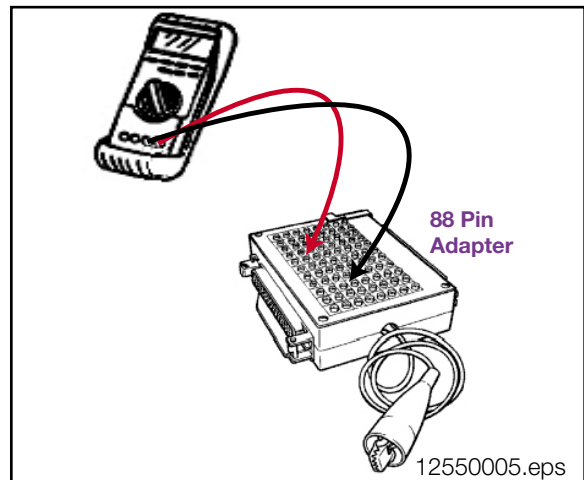
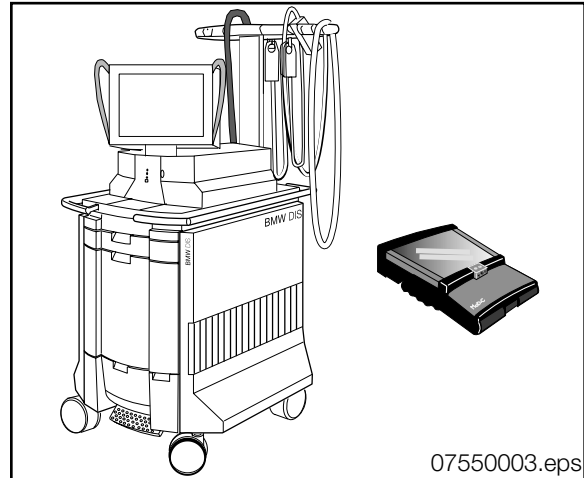

Performance Controls

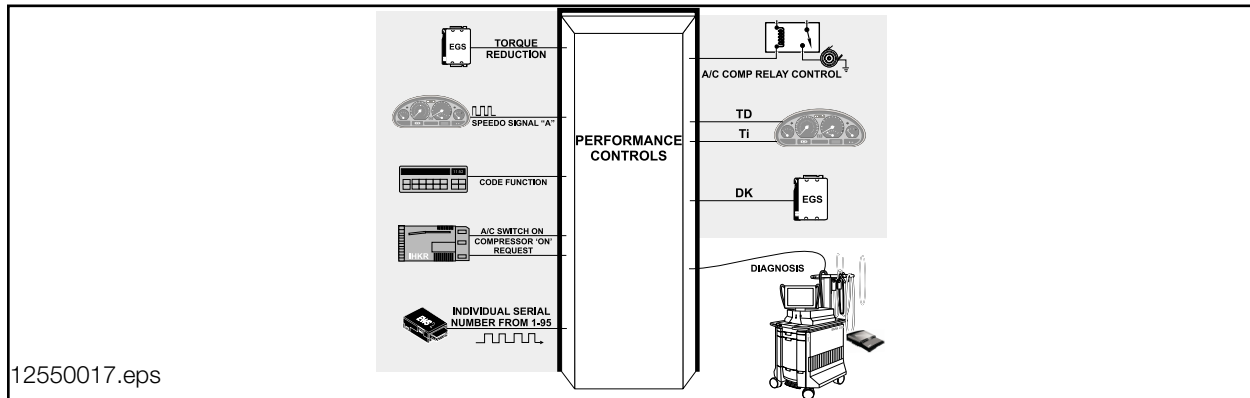

12550017.eps

Engine Speed Signal (TD): is produced by the ECM as an output function. The TD signal is a processed square wave signal that indicates engine rpm. The signal is made available to other control modules including the Instrument Cluster, EWS and the 20 pin Diagnostic Socket.

The TD output is a square wave modulated signal. The frequency of the signal is directly proportional to RPM. The receiving control module detects RPM by the number of pulses.

Load Signal (Ti): is produced by the ECM as an output function that represents the actual amount of fuel injected. It is made available to other control modules as an input for operation. These control modules include:

- | |
|---|
| • OBC=Fuel consumption for MPG and Range. |
| • Instrument Cluster = MPG Gauge |
| • EGS = Load signal for shift points (If Equipped) |

The Ti output is a processed square wave signal. The frequency of the signal is proportional to engine RPM. The pulse width and duty cycle will vary to reflect the injection quantity.

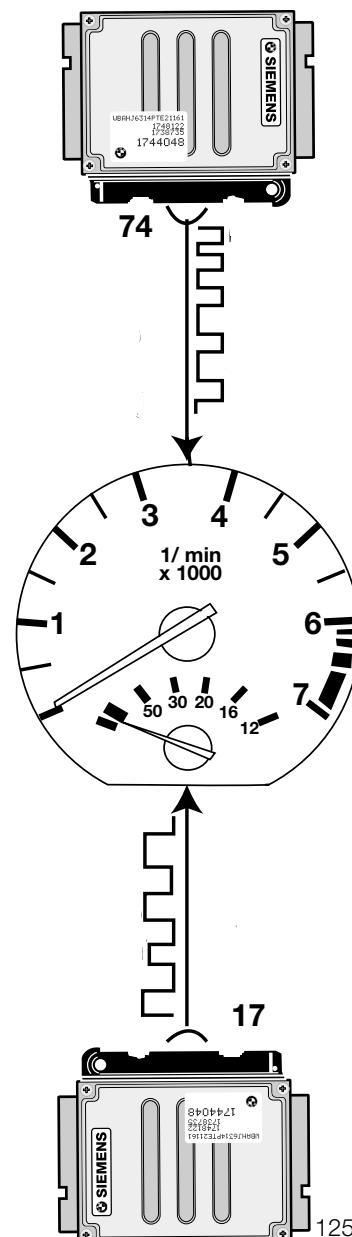

12550019.eps

Engine Speed (TR) for EGS: is an additional variation of the engine speed signal. The “TR” signal is produced ECM as an additional output function. Like TD, “TR” is a processed signal that indicates engine rpm for the EGS (if equipped) to determine shift points.

The TR signal is a pulse wave signal. The frequency of the signal directly proportional to RPM. The signal is overlapped on the fuel pump relay control signal from the ECM.

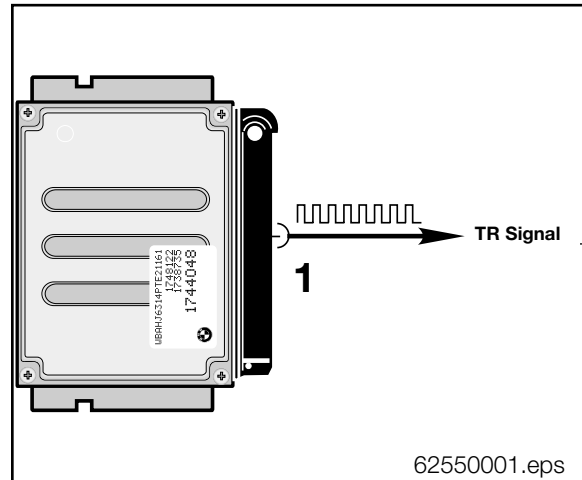

Throttle Position (DKV) for EGS: is the output signal to the EGS Control Module (if equipped). The DKV signal is a pulse width modulated signal directly proportional to the linear throttle position sensor input signal.

This output signal is used by the EGS Control Module for determining shift points.

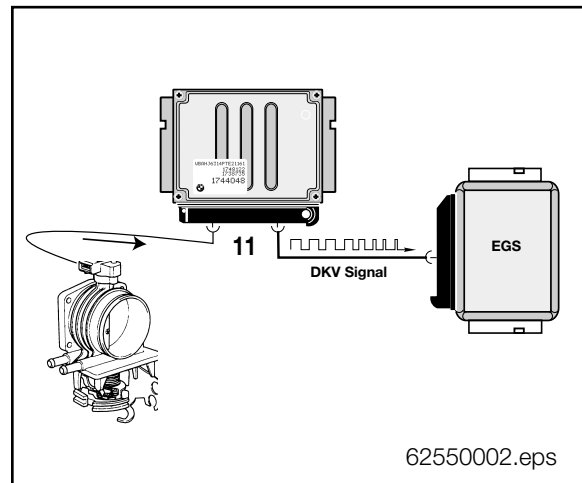

EGS Ignition Timing Intervention Signal: The ECM receives an input signal from the EGS Control Module (if equipped) that will retard the ignition timing. This is a momentary ground signal from the EGS during a gear change to reduce engine torque for smoother shifts.

The EGS releases the ground so the ECM will resume ignition timing advance at the completion of the “shift”.

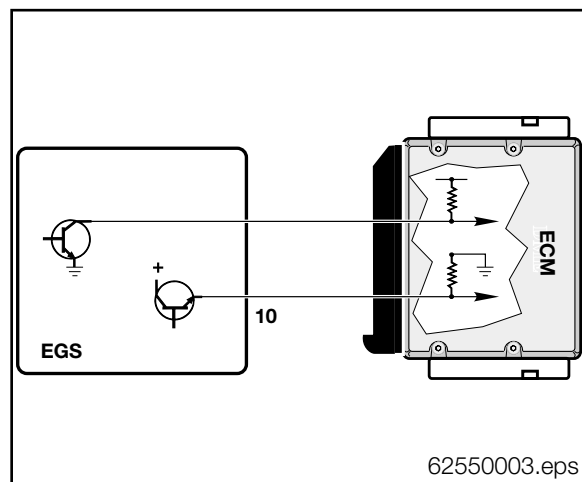

A/C Compressor Control: is an output of the ECM. The ECM controls the A/C Compressor Relay based on signals from the IHKA/IHKR Control Modules.

When the driver selects the “snowflake” button, the IHKA/IHKR Control Module signals the ECM (AC) which “arms” it for compressor activation.

The ECM prepares for the additional load of the compressor by modifying the ignition timing and stabilizing idle speed.

When A/C compressor activation is required the IHKA/IHKS signals the ECM through the high/low refrigerant pressure switches (KO). The ECM will provide a ground circuit for the A/C Compressor Relay.

The A/C Compressor Relay is deactivated during wide open throttle acceleration at low speeds to allow the engine to quickly achieve maximum power.

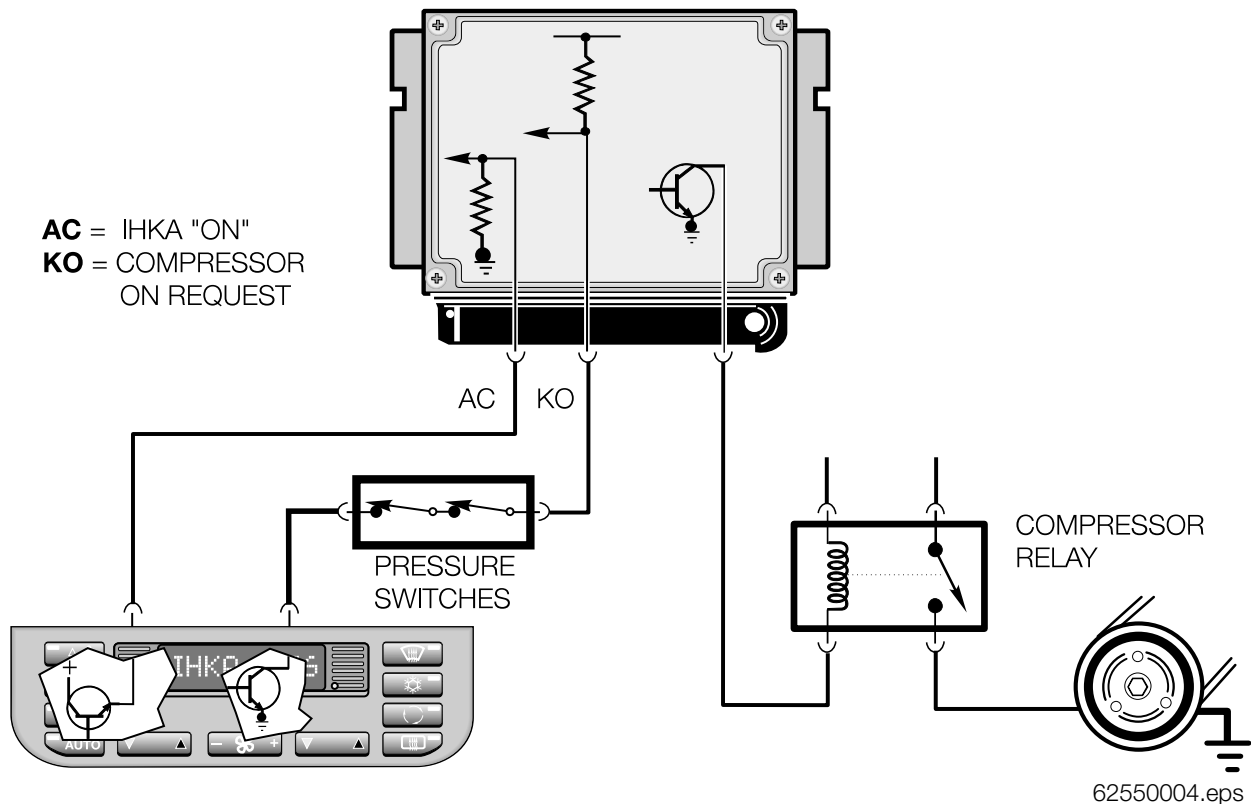

Driveaway Protection System Interface EWS I (1-94 thru 12-94 production): was added to all vehicles in January 1994. It is controlled by the Central Locking System of ZKE and by the On-Board Computer code function (if equipped).

The Starter Immobilization Relay is activated when:

- **The vehicle is locked from the outside (Central Locking - GM output to Relay).**
- **The On-Board Code function is set.**

An activated relay performs two functions to deter vehicle theft:

- **Ignition and Injection functions of DME are disabled (switched high output signal.)**
- **The KL 50 start signal circuit is opened to prevent starter operation.**

* Conventional troubleshooting using the ETM.

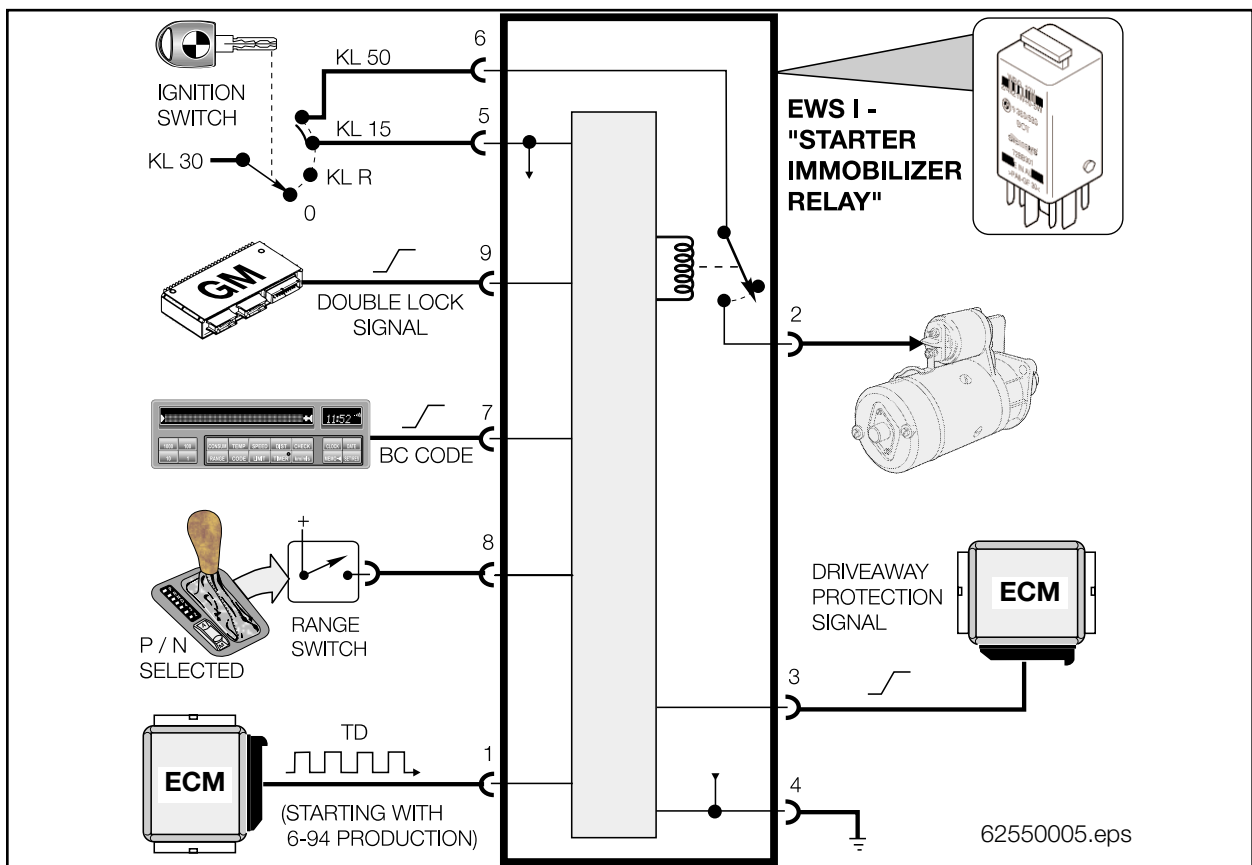

62550005.eps

Driveaway Protection System Interface EWS II (from 1-95 production): and ECM Control Modules are synchronized through an **individual serial number (ISN)**. The ISN is a unique code number that is permanently assigned to the ECM and also stored in the EWS II Control Module. The ISN must match every time the ignition is switched “ON”, before the ECM drive away protection feature will be cancelled.

- Engine Control Modules designed to operate with the EWS II system will not interchange with ECMs from previous models.
- The ISN replaces the BC Code input to the ECM.
- The ISN is unique to each ECM and cannot be changed or overwritten. The ISN is transferred / stored in the EWS II Control Module using the DIS/MoDIC (including diagnosis).
- Everything the ignition is switched “ON” the ISN number is sent from the EWS Control Module to the ECM, as a digital coded signal. The numbers must match before the ECM will release the driveaway protection.
- The ISN is continuously sent to the ECM as long as the ignition is switched on (KL15).
- The ECM will disregard the loss of the ISN after the engine is running.

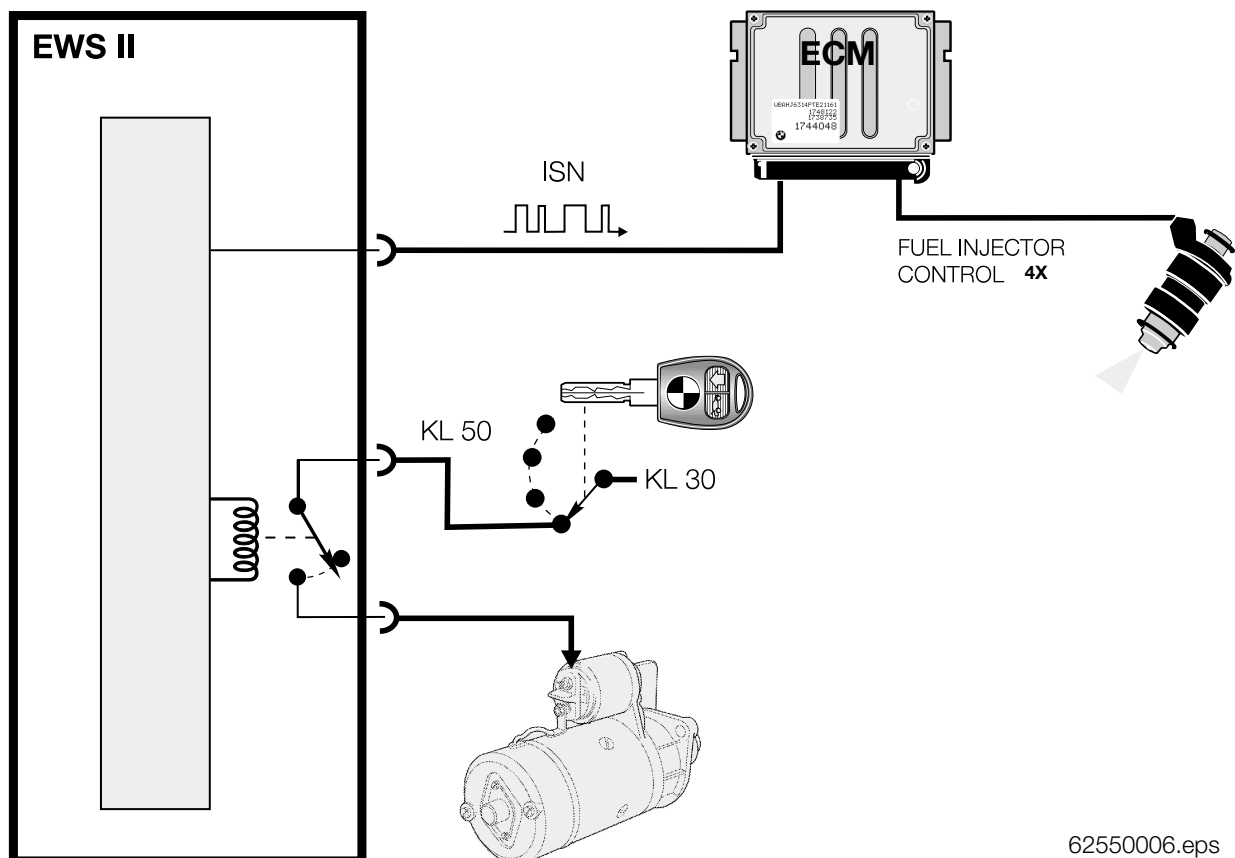

62550006.eps

Variant Coding

The ECM used in the M1.7.2 system is a codeable module that requires Variant Coding if it is replaced. The control module is programmed with “resident data” stored in the EPROM and Variant Coding simply means that one of the “data sets” will be activated for the engine/vehicle.

DME (ECM) Variant Coding is performed with the DIS/MoDIC using the latest software:

<ul style="list-style-type: none"> • DME Variant Coding uses a 4 Digit code to determine which of the internal maps (data sets) to utilize.
<ul style="list-style-type: none"> • The 4 digit code describes which maps to use.
<ul style="list-style-type: none"> • The proper variant code can be found on the cover of the old ECM or Modic variant coding software.
<ul style="list-style-type: none"> • The actual program software can be found for DME variant coding can be found only in DME Programming software.
<ul style="list-style-type: none"> • A codeable DME can only be coded 8 times.

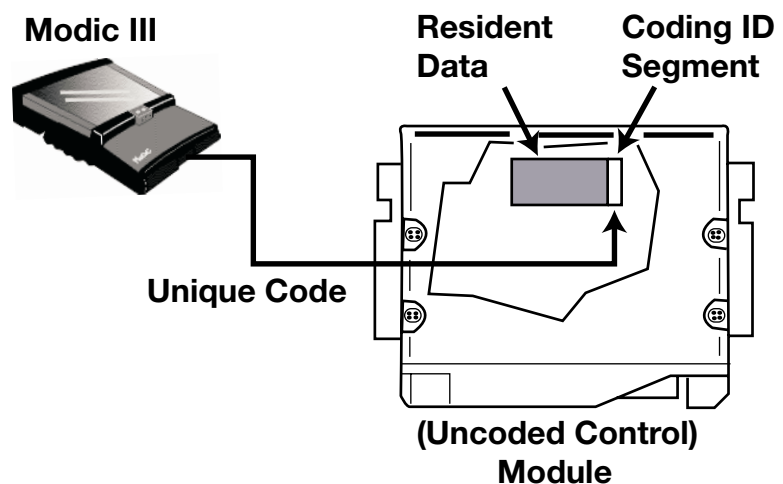

12550003.eps

Please refer to the following Service Information Bulletins for updated information on the ECM regarding coding:

<ul style="list-style-type: none"> • SI #09 Group for the latest on Programming/Coding Explanation
<ul style="list-style-type: none"> • SI #12 14 97 M42 Fault Code 200/333
<ul style="list-style-type: none"> • SI #12 15 97 M42 Acceleration Jot in 2nd and 3rd Gear
<ul style="list-style-type: none"> • SI #12 09 95 M42 ECM (DME) 1.7.2 Fault Code 41

Workshop Hints

The following signals are “manufactured” by the ECM for other control modules and are not the “raw” inputs to the ECM.

These signals should be tested if another Control Module, gauge or function is inoperative due to a lack of the signal(s).

With the 88 Pin adapter and the DIS Oscilloscope (Preset Measurements) the following signals can be observed with the ECM installed and engine running:

1. TD = Engine RPM
2. Ti = Fuel Injection
3. TR = Engine RPM (for EGS if equipped)
4. DKV = Throttle Position (for EGS if equipped)

The waveform on the scope should be even, continuous, without interference and of sufficient height (indicates signal strength). Examples of “good” patterns are shown to the right.

The test should be performed at the ECM and at the output Control Module/component.

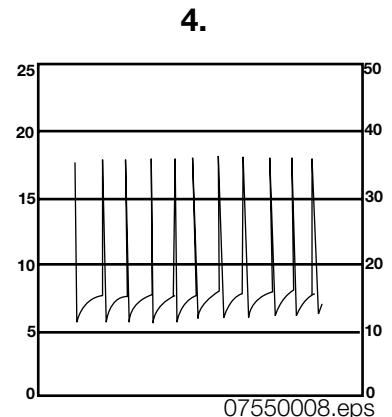
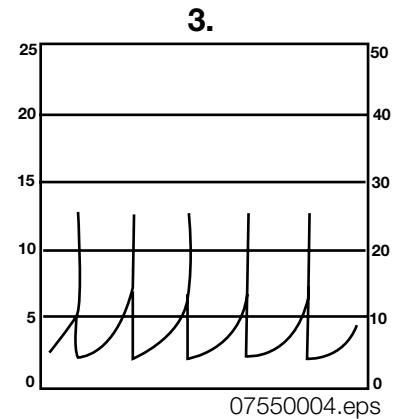
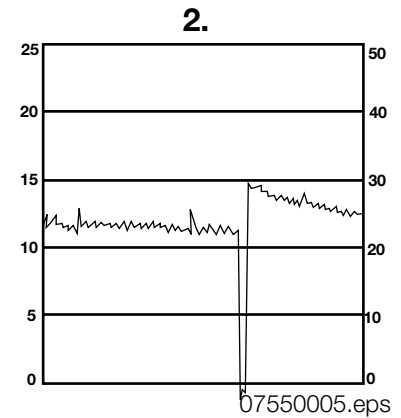
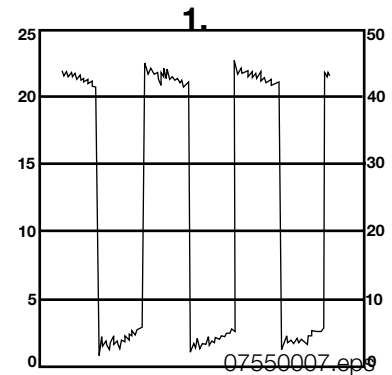

Tools and Equipment

The DIS/Modic as well as a reputable hand held multimeter can be used when testing inputs/components.

It is best to make the checks at the ECM connection, this method includes testing the wiring harness.

The correct Universal Adapter for the M1.7.2 application should be used (#88 88 6 614 410). This will ensure the pin connectors and the harness will not be damaged.

The interior of this Universal Adapter is shielded, therefore it is vital that the ground cable is connected to the vehicle chassis whenever the adapter is used.

The adapter uses a Printed Circuit board inside keeping the capacitive and inductive load to a minimum.

When installing the Universal Adapter to the ECM (located below the windshield on the passenger side of the engine compartment), make sure the ignition is switched off.

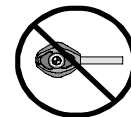
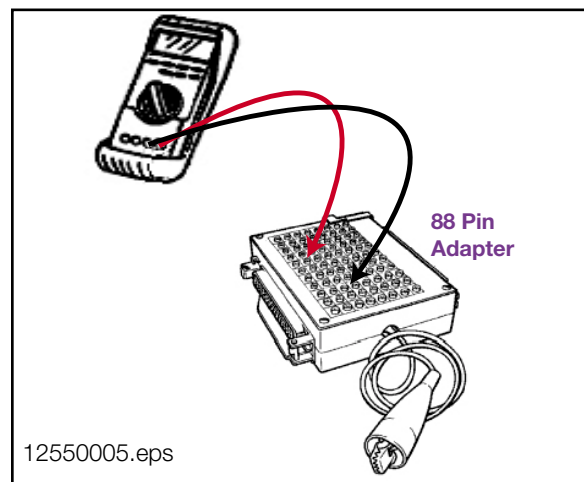
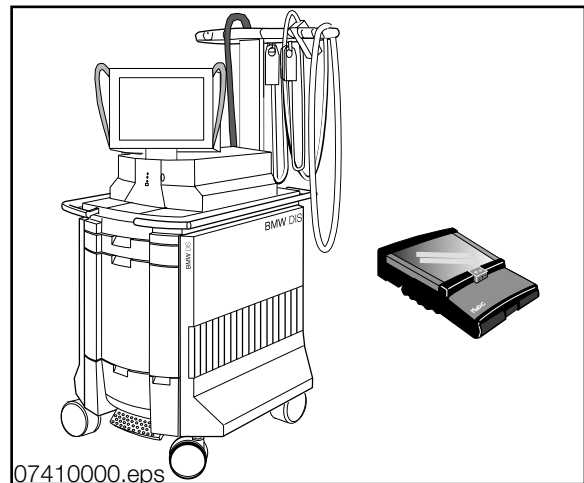

Review Questions

1. Describe the Power Supply for the Fuel Injectors: _____

2. Name the Components of the Fuel Supply System:

3. List the inputs required for ignition operation:

4. Describe the Knock Sensor Function: _____

5. Name two types of Emissions the ECM controls: _____

6. List two reasons for the "CHECK ENGINE" Light to illuminate:

7. List four different tests that can be performed on the fuel injectors:

8. Describe Semi-Sequential Injection: _____

9. EWS (I or II) affects what ECM output functions to deter vehicle theft?

