Table of Contents

PARK DISTANCE CONTROL (PDC)

Subject	Page
Introduction.	3
System Overview.	3
Components	
PDC Control Unit.	4
Sensors.	5
PDC Button.	6
Interfaces.	6
Principle of Operation	
Activation of the PDC	8
PDC Acoustic Warning.	8
PDC Visual Warning.	9
Check Control Message.	10
Diagnosis.	10
Review Questions.	11

PARK DISTANCE CONTROL (PDC)

Model: E65 - 745i

Production Date: 11/2001 - Start of Production

Objectives:

After completing this module you should be able to:

- Recognize the changes made to the E65 PDC system over the previous model.

Introduction

The first PDC was introduced by BMW in the U.S. for the E38 in 1995. The PDC of the E65 is a further development of the E38 PDC.

PDC assists the driver when maneuvering into and out of parking spaces. The signal tones and a visual display indicate the current distance to an obstacle.

The new features of the PDC are:

- Acoustic distance warning using the audio system speakers
- Visible distance indicator in the Control Display (CD)
- Check Control messages in the Kombi and CD

System Overview

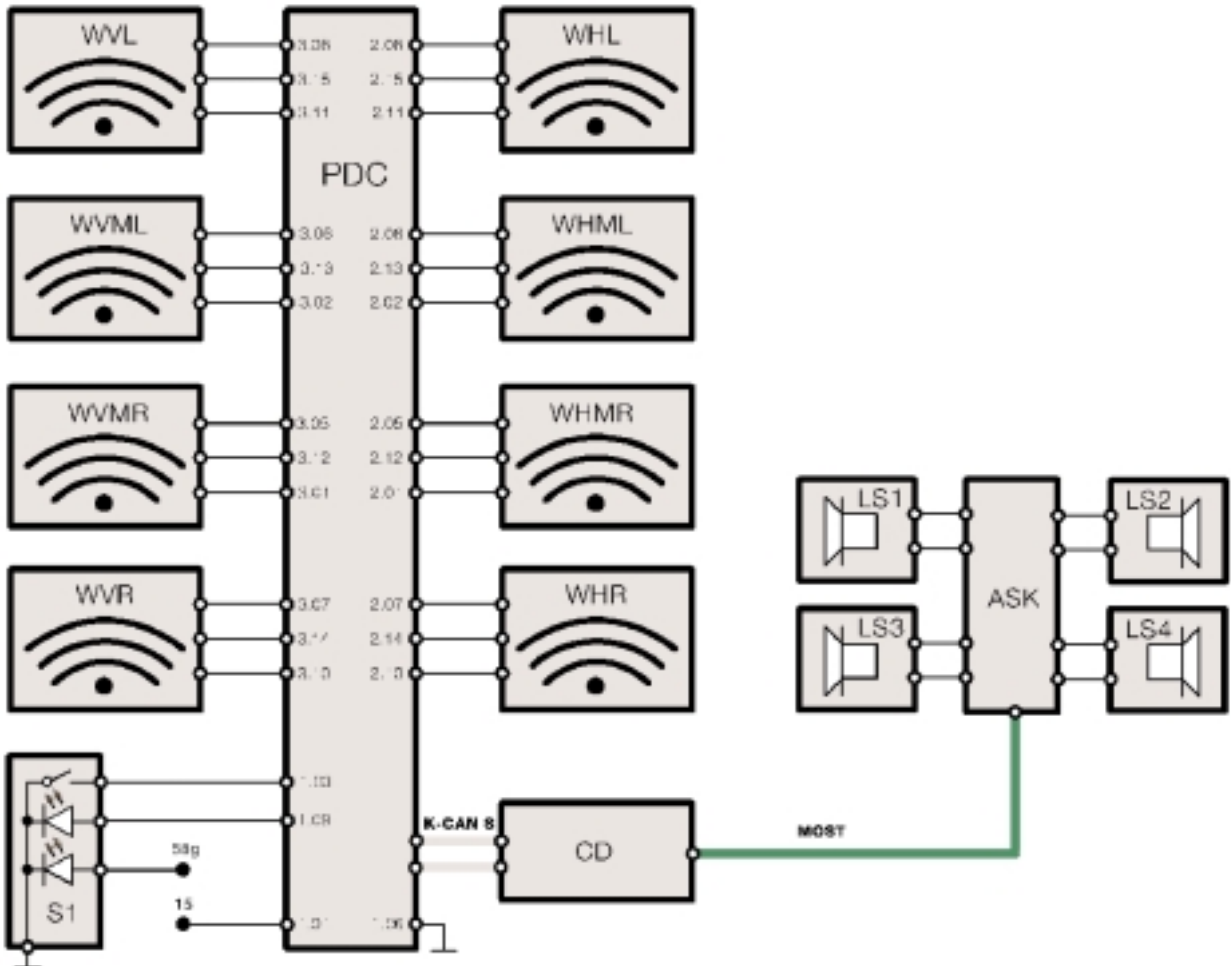

Components

PDC Control Unit

The PDC Control Unit is located in the right rear corner of the luggage compartment.

Its main tasks are:

- Activation of sensors and reception of echo signals.
- Evaluation of the received echo signals.
- Activation of the function indicator (LED in the switch).
- Sending messages via K-CAN-S to ASK and the CD.
- Monitoring the inputs and outputs.
- Management of the diagnosis and test functions.

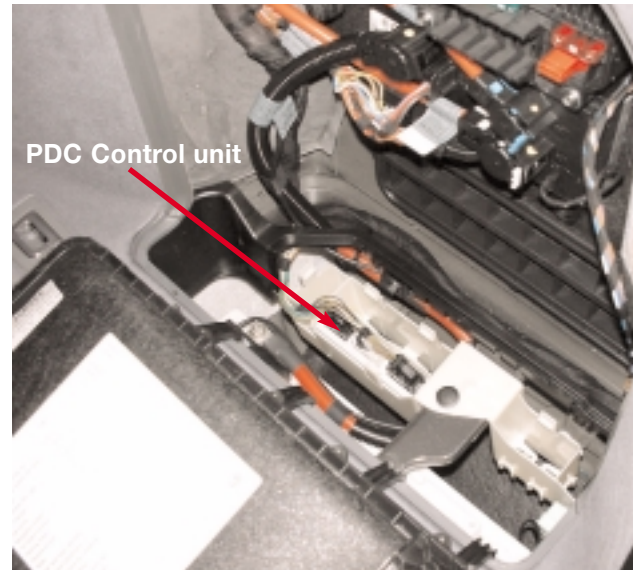

PDC uses the echo sounding principle to calculate the distances between each of the 4 sensors in the front and rear bumpers and any obstacle that might be present.

In addition, a three-way calculation can be used to calculate the effective distance to the bumper in the case of an obstacle between two sensors.

This three-way calculation is enabled by co-sensing of the neighboring sensors.

An active sensor system in the converter processes the received echo signals, performs the evaluation and communicates across a bi-directional data line with the control unit.

Sensors

The PDC system of the E65 uses 8 sensors in total, 4 in the front bumper and 4 in the rear.

The control unit sends a digital signal to set the ultrasonic sensor either in a combined transmit and receive mode or in a receive only mode.

Combined mode

The sensor first transmits a packet of ultrasonic impulses and then receives the echoes reflected by the obstacle within its sensing range.

On the basis of the time span between transmission and reception, the control unit calculates the distance to the obstacle.

Receive Only Mode

The sensor receives the impulses deflected by the neighboring sensors. The evaluation of these signals in the control unit improves the certainty of detection of the system.

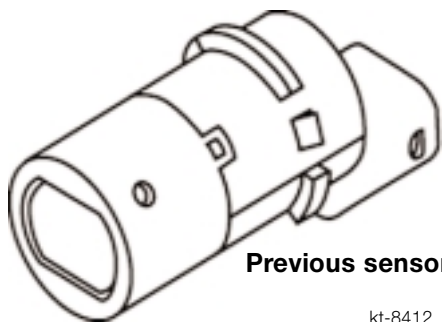

Previous sensor

kt-8412

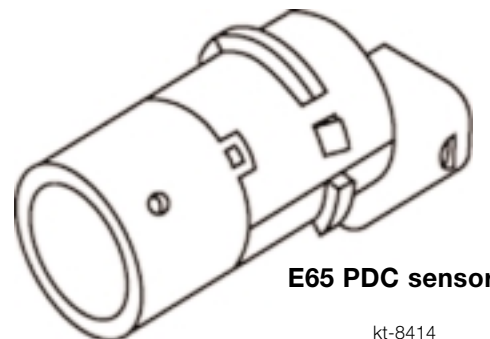

E65 PDC sensor

kt-8414

The design of the sensor varies from that used until now in that the outer membranes are completely round instead of oval.

The advantages of this new round membrane shape are the greater detection range and lower sensitivity in wet conditions. The sensors are always painted in body color.

PDC Button

The PDC button is to the left of the start/stop button and it consists of the following components:

- Button
- Function indicator (LED)
- Location light



The button can be used to activate or deactivate PDC manually. The locating light is connected to terminal 58g. The function indicator LED is connected to the control unit.

When the PDC is activated, the LED turns on permanently. In the event of an error message, it flashes at a frequency of 2 Hz.

Interfaces

The communication with the vehicle electronics takes place across the K-CAN S.

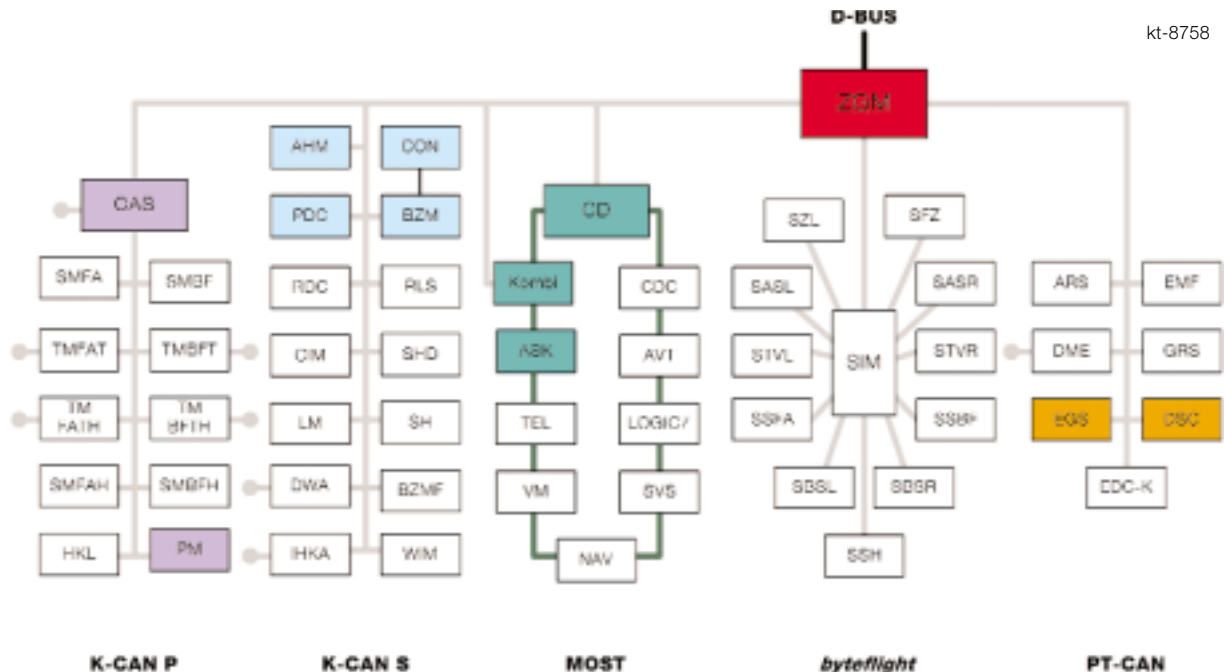

Audio System Controller (ASK)

The acoustic distance warning is output through the front midrange speaker of the audio system in the doors and in the rear shelf. The signal tones for all 4 loudspeakers as well as their intervals are processed in the ASK and mixed with the current audio output.

The dedicated speakers used until now are no longer used in the E65.

Control Display (CD)

If the “PDC Pic” option is enabled from the “Settings” menu, the visual distance warning is displayed in the CD and the graphic is generated in the CD.

Instrument Cluster

The instrument cluster is used by the PDC as a display unit for Check Control (CC) messages. The PDC control unit also receives the outside temperature as well as the mileage reading from the instrument cluster.

Ice and dew can lead to false activations of the ultrasonic sensors. In order to reduce the effect of this phenomenon, the response characteristics are adapted via software as of +6°C and colder.

In the case of a fault code entry in the fault memory, the km reading and the outside temperature are also stored.

Dynamic Stability Control DSC

The DSC control unit provides the speed signal.

Adaptive Gearbox Control (AGS)

The AGS provides the reverse gear signal for automatic activation of the PDC.

CAR Access System (CAS)

The CAS reports the terminal status (KLR, KL15, KL50).

Power Module (PM)

The PM telegrams the vehicle battery voltage.

Principle of Operation

Activation of the PDC

The system is activated automatically with a delay of approximately one second when the ignition is on and the selector lever is moved reverse.

After a driving distance of 50 m or a speed of 30 km/h is exceeded, the system switches off. The indicator LED in the button goes out when the system is no longer active.

The PDC can also be manually activated or deactivated by using the PDC button.

PDC Acoustic Warning

The distance to an obstacle is indicated by an intermittent tone according to its distance from the sensor. If, for example, an obstacle is detected to the left front of the vehicle, the sound signal is issued at the left front speaker.

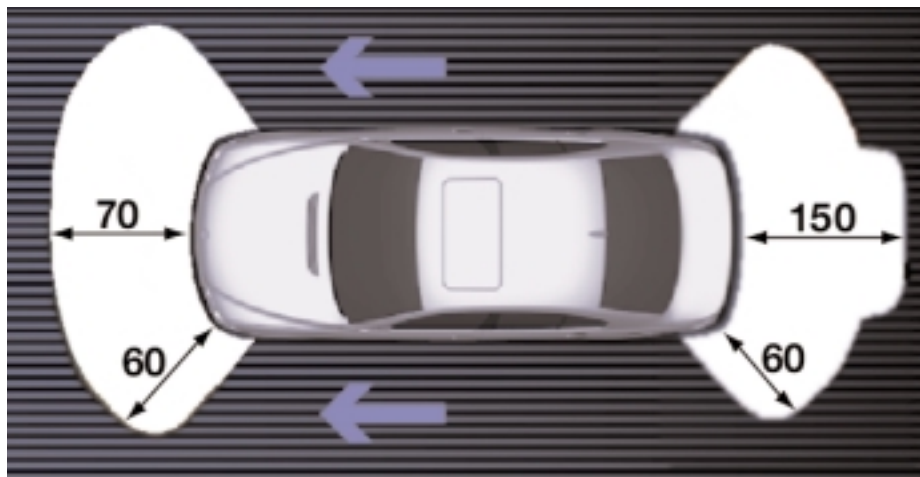

kt-8406

The closer the vehicle comes to the object, the shorter the frequency of the signal becomes. If the distance to a detected object is smaller than approximately 30 cm (11 in.), a continuous tone is issued.

The sound signal is interrupted after approximately 3 seconds if the vehicle is driven parallel to a wall.

This interruption does not occur in the continuous tone mode (distance smaller than 30 cm).

PDC Visual Warning

The distance to an obstacle can also be displayed visually in the Control Display.

To enable the visual display Select “settings” in the CD and then select the “other vehicle functions” page which is displayed as the silhouette of a car. Activate it by pressing “PDC pic.”

Once the visual display is enabled it will always display whenever the PDC becomes active.

The display takes priority over any item that is currently being displayed on the Control Display. It can be temporarily switched off by pressing down on the Controller.

To disable the visual display completely requires returning to the settings menu and de-selecting it.

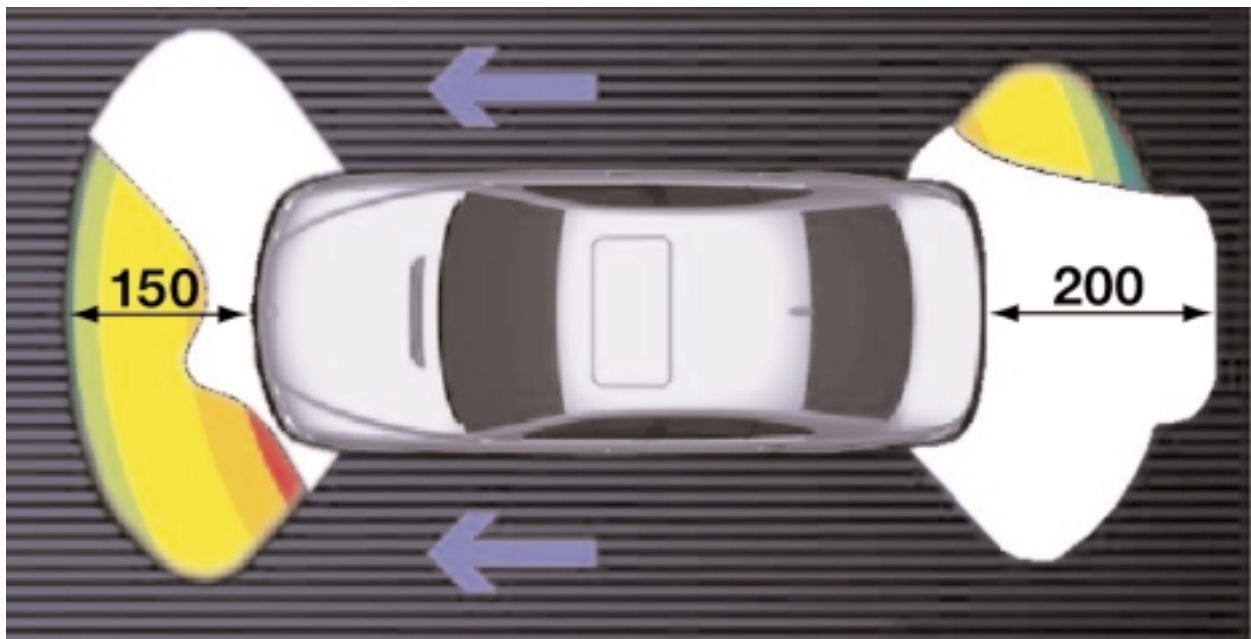

420307

Maximum visual detection range displayed in the CD

The visual display uses color to distinguish how close an object is, the following colors are used:

- Green: over 100 cm (39 inches)
- Yellow: 100 to 50 cm (38 to 19 inches)
- Red: less than 50 cm (less than 19 inches)

Check Control Message

If there is a fault in the PDC system, no acoustic and visual warning is issued. The indicator LED in the PDC button flashes.

The following Check Control Message is issued:

Check Control Message displayed in KOMBI	Message displayed in Control Display
PDC failure! 	"PDC failure!" No acoustic warning available for PDC. Please contact your BMW center as soon as possible.

Diagnosis

The following system components are monitored and stored as faults in the non-volatile fault code memory.

- Sensors
- Data line to the sensors
- Voltage supply for sensors
- Button
- Function indicator LED of the button
- Control Unit
- K-CAN S

In addition to the type of fault, the following environmental conditions are also stored:

- Frequency
- Kilometer reading
- Outside temperature

Review Questions

1. What control unit is responsible for generating the acoustic output of the PDC? How does it receive the request? _____

2. How is the visual display of the PDC enabled? Does it have to be turned on this way every time the driver wishes to have the visual display? _____
