

Move selector lever into "P" setting.

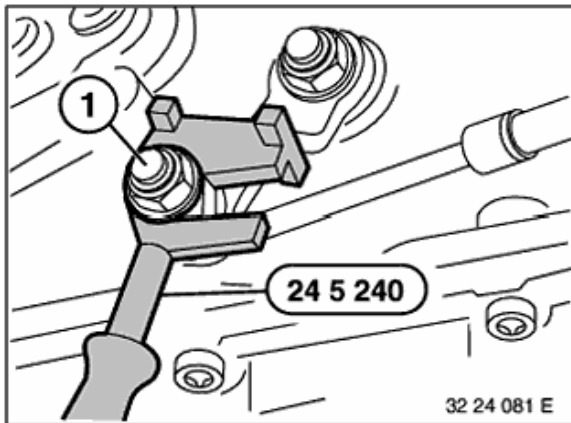

For cable clamping up to 8.95:

Fit special tool 24 5 240 to the shift lever.

Note:

This can only be fitted in "P" position.

Loosen nut (1).

Installation:

Adjust shift lever,
refer to 24 00 007.

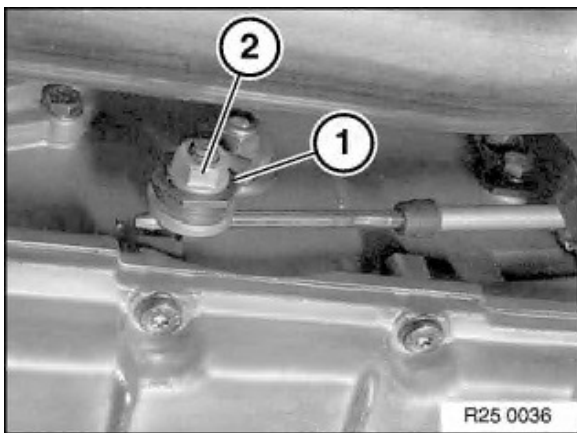

Cable clamping from 8.95:

Brace clamping section (1) and loosen nut (2).

Installation:

Adjust shift lever,
refer to 24 00 007.

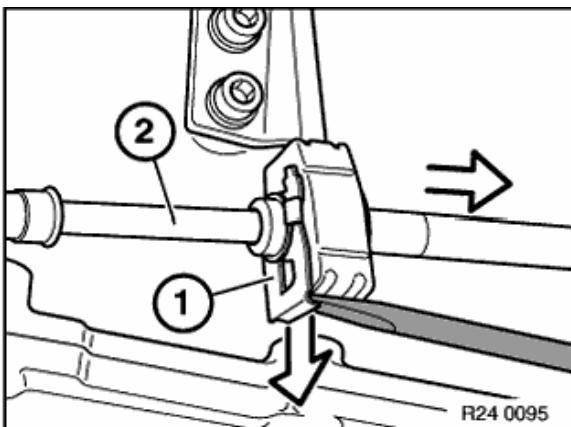

Lift out retaining plate (1) with a screwdriver. Remove cable (2).

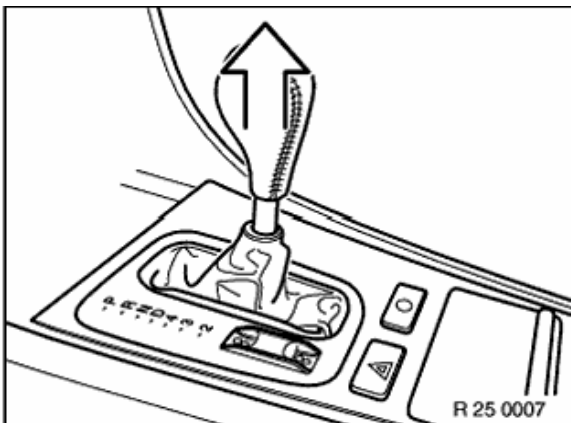

Pull handle off with one firm movement.

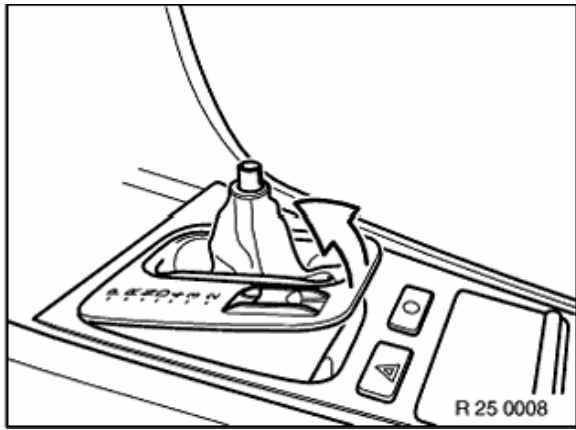

Lift out cover plate.

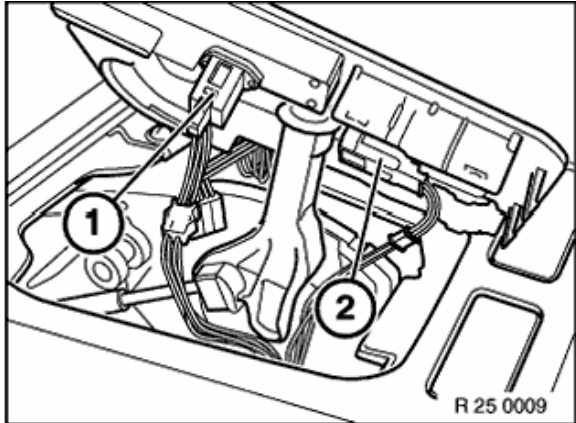

Remove cable connectors (1 and 2).

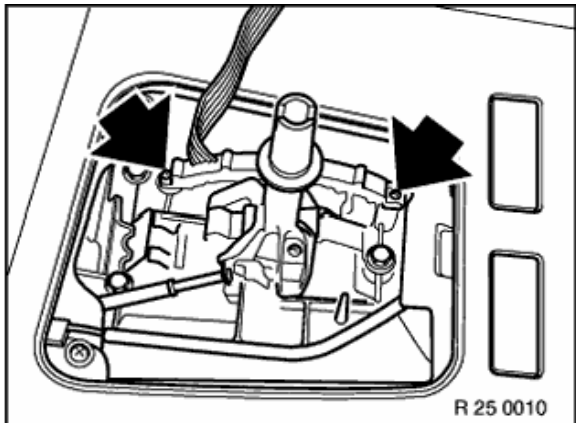

Unfasten screws.
Remove position switch.

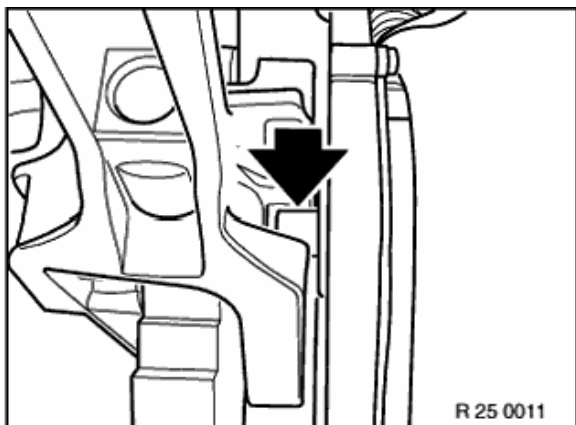

Installation:

Pin in switch must locate in recess on selector lever.

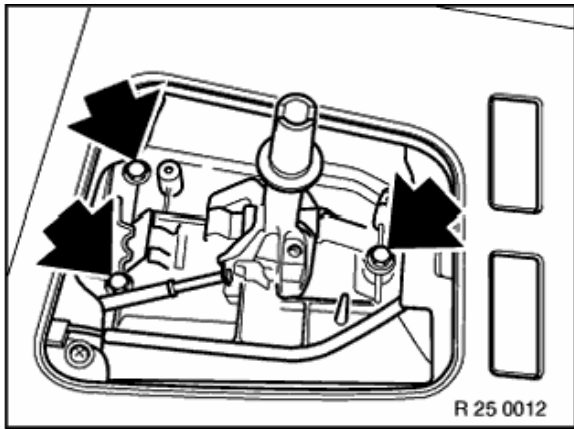

Unfasten screws.

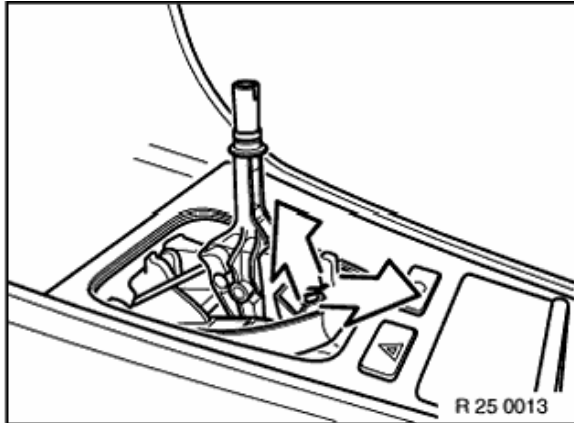

Lift out shift lever with mounting bracket and remove by pulling backwards.

Installation:

Coat rubber lip with anti-friction coating, refer to BMW Parts Service.

Ensure that rubber lip makes contact with carpet on transmission tunnel.