

Important!

Note "General Information",
refer to 34 00 ...

After the work steps are completed, bleed the brake
system, refer to:

Vehicles with ABS 34 00 047

Vehicles with ABS/ASC+T, DSC1, DSC2 34 00 048

Vehicles with DSC3 34 00 050

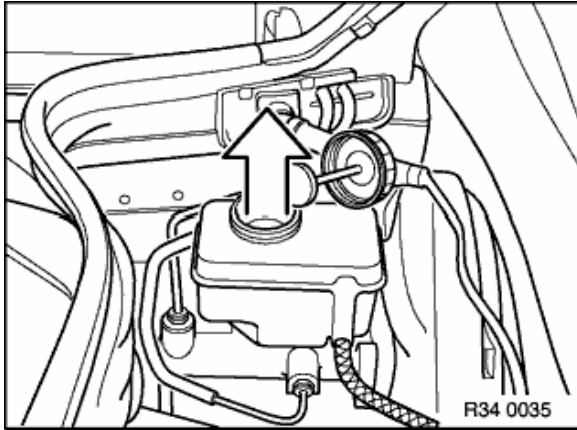

Suck the brake fluid out of the expansion tank. Use a suction
bottle used exclusively for drawing off brake fluid.

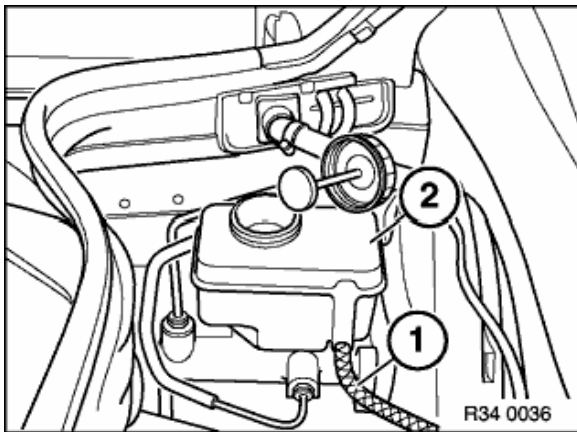

Pull off supply hose on clutch hydraulics (1).

Lift out the expansion tank (2) from the master brake cylinder by
tilting it laterally.

Installation:

Push the expansion tank vertically onto the master brake
cylinder.

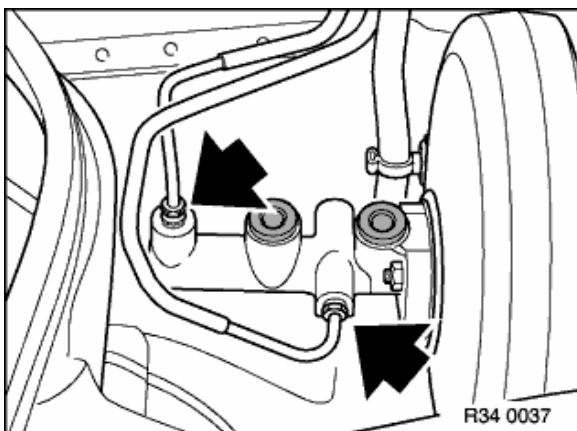

Loosen the screw connections of the brake lines.

Note:

Close off the brake lines and the master brake cylinder
using the appropriate seal plugs.

Installation:

Tightening torque,
refer to Technical Data 34 32 1AZ

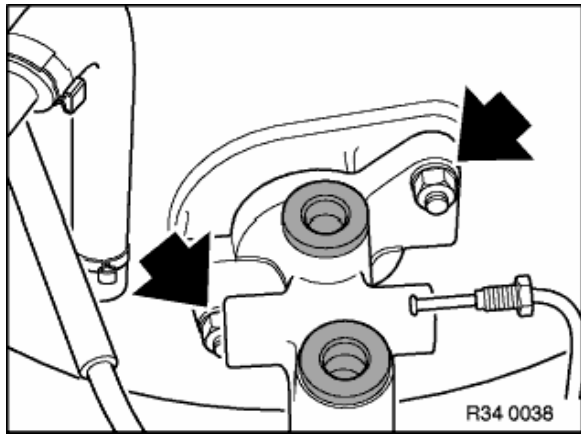

Loosen the nuts and pull the master brake cylinder out of the brake unit.

Installation:

Replace self-locking nuts.
Tightening torque,
refer to Technical Data 34 31 1AZ

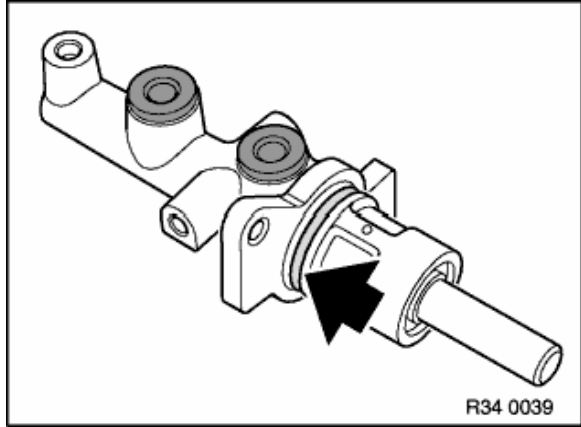

Installation:

Replace O-ring.

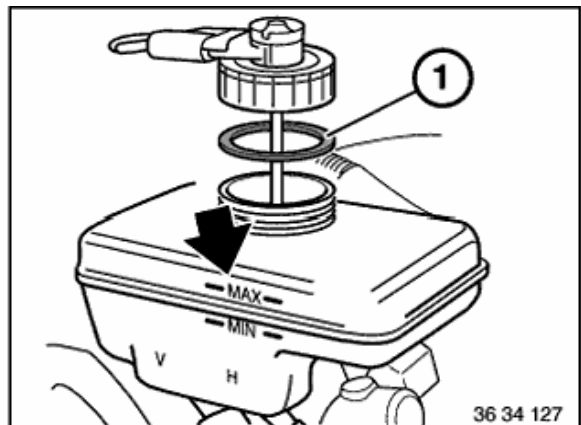

Fill expansion tank up to "MAX" mark with new brake fluid, refer to BMW Service Operating Fluids.

Check seal (1).